

JAGUAR TYPE E 3L8 "RACING"

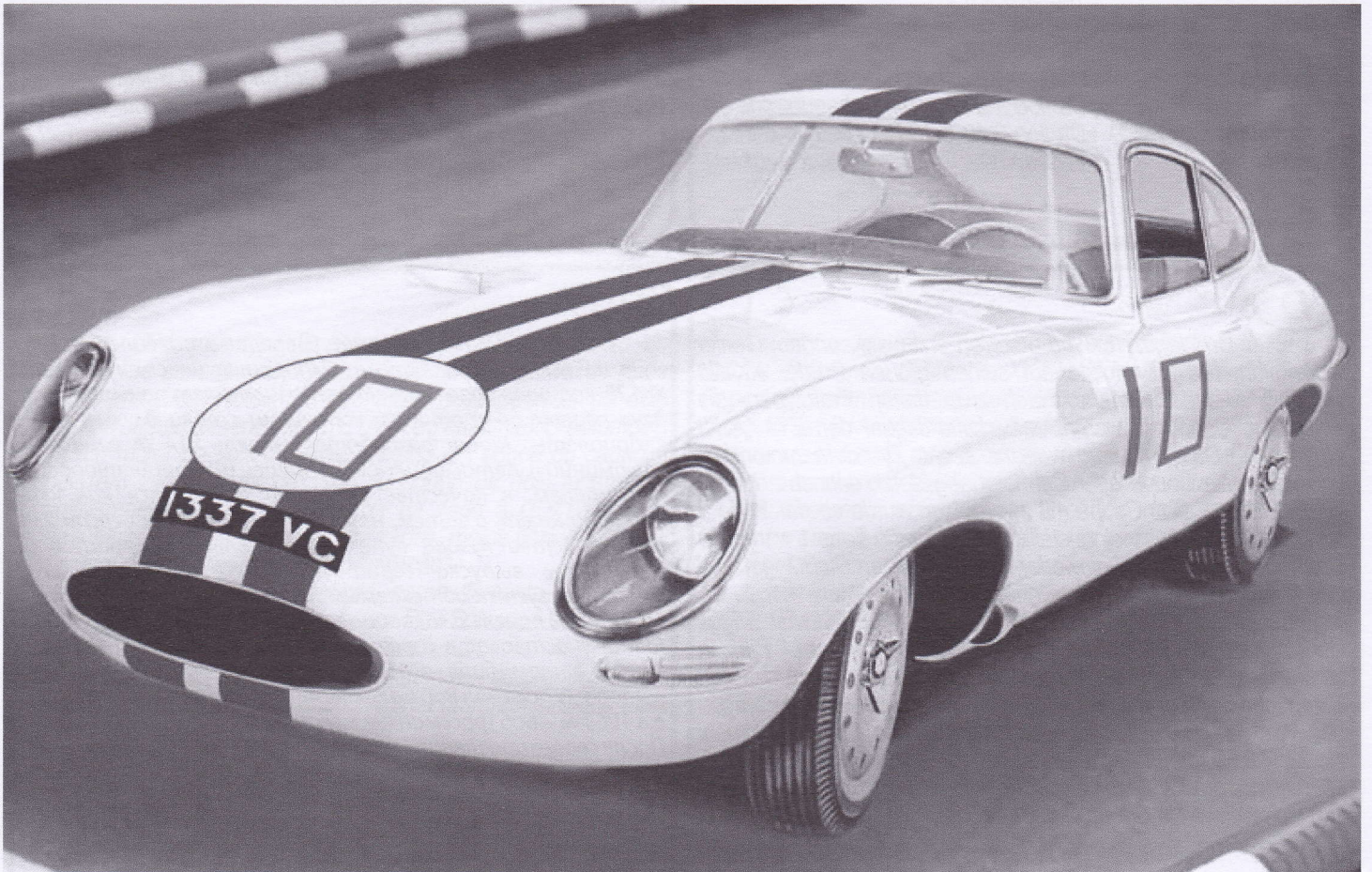

80783

F

La Jaguar type E fit son apparition en 1961 au salon de Genève. Elle succédait à la XK120 de douze ans son aînée. Après les deux premiers prototypes, qui étaient des cabriolets deux places, Jaguar développa la E1A (A pour aluminium). La voiture était motorisée par un six cylindres et fut déclinée en coupé ou cabriolet, puis en 2+2 à partir de 1966. Le coupé deux places fut définitivement abandonné à partir de la série 3 (1971-1975). La série 1 se caractérise par ses phares carénés, ses demi-pare-chocs et un tableau de bord « type aviation ».

La Jaguar fut engagée en compétition, notamment avec Briggs Cunningham au volant assisté de Roy Salvadori en 1962 (4e au Mans), et en 1963 (9e) avec Bob Grossman.

A sa sortie la Jaguar type E était la voiture de production la plus rapide du monde, frôlant les 250 km/h. Plus de 72500 exemplaires ont été construits.

En 2010, la marque au félin a fêté son soixante quinzième anniversaire, et fut célébrée partout dans les clubs de collectionneurs.

CARACTERISTIQUES

Empattement	: 243 cm
Voie avant et arrière	: 126 cm
Longueur	: 437 cm
Largeur	: 162 cm
Moteur	: 6 cylindres, 3,8 litres
Puissance	: 265 cv
Suspension	: indépendante aux quatre roues
Freins	: Dunlop à disque pour chaque roue
Pneumatiques	: Dunlop 6,40 X 15 RS5
Vitesse maximale	: 255 km/h

GB

The Jaguar E-Type was introduced at the 1961 Geneva Motor Show. It followed the XK120, twelve years its senior. After the first two prototypes, which were two-seat convertible, Jaguar developed the E1A (A for aluminium). The car was powered by a six cylinder engine and was first available as either as a two-door sedan or convertible, and then as a 2+2 door model as of 1966. The two-seat sedan was definitively withdrawn as of series 3 (1971-1975). The Series 1 was characterised by its glass-covered headlights, half-bumpers and an aircraft-style dashboard.

The Jaguar was raced competitively, in particular in 1962 with Briggs Cunningham at the wheel, assisted by Roy Salvadori (4th at the 24 Hours of Le Mans), and in 1963 (9th) with Bob Grossman. Upon its release, the Jaguar E-Type was the world's fastest production car, with a top speed approaching 250 km/hr. More than 72,500 units were built.

In 2010, the feline brand celebrated its seventy-fifth anniversary, which was widely celebrated by collectors' clubs.

SPECIFICATIONS

Wheelbase	: 243 cm
Front and rear track	: 126 cm
Length	: 437 cm
Width	: 162 cm
Engine	: six cylinders, 3.8 liters
Power	: 265 hp
Suspension	: independent on all four wheels
Brakes	: Dunlop disc brakes on all four wheels
Tires	: Dunlop 6.40 x 15 RS5
Top speed	: 255 km/h (160 mph)

D

Der Jaguar E-Type erschien erstmalig auf dem Genfer Auto-Salon 1961. Er folgte auf seinen großen Bruder XK120 mit zwölf Jahren Abstand. Nach zwei ersten Prototypen, die zweisitzige Cabriolets waren, entwickelte Jaguar den E1A (A für Aluminium). Das Fahrzeug war mit sechs Zylindern motorisiert und wurde als Coupé oder Cabriolet abgesetzt, danach ab 1966 mit 2+2 Sitzen. Das Coupé mit zwei Sitzen wurde ab der Serie 3 (1971 – 1975) definitiv eingestellt. Typisch für die Serie 1 waren die stromlinienförmigen Scheinwerfer, die zweiteiligen Stoßfänger und das Armaturenbrett in „Flugzeugoptik“.

Jaguar engagierte sich im Sport, insbesondere 1962 mit Briggs Cunningham am Steuer und Roy Salvadori als Partner (4. Platz in Le Mans) und 1963 (9. Platz) mit Bob Grossmann.

Bei Erscheinen war der Jaguar E-Type der schnellste Serienwagen der Welt, der bis zu 250 km/h erreichen konnte. Es wurden mehr als 72.500 Exemplare gebaut.

2010 feierte die Marke mit der Raubkatze ihren 75. Geburtstag und ließ sich weltweit in Sammlerclubs feiern.

TECHNISCHE DATEN

Radstand	: 243 cm
Spur vorne und hinten	: 126 cm
Länge	: 437 cm
Breite	: 162 cm
Motor	: 6-Zylinder; 3,8 Liter
Leistung	: 265 PS
Aufhängung	: unabhängig an allen vier Räder
Bremsen	: Dunlop Scheibenbremsen an allen Rädern
Bereifung	: Dunlop 6,40 x 15 RS5
Spitzengeschwindigkeit	: 255 km/h

RU

Автомобиль Jaguar E впервые появился в 1961 году на выставке в Женеве. Он пришел на смену модели XK120, которая появилась на двенадцать лет раньше. После двух первых прототипов, которыми стали двухместные кабриолеты, Jaguar разработал модель E1A (A означает «алюминий»). Автомобиль был оснащен шестицилиндровым двигателем, в качестве вариаций выпускался как купе или кабриолет, а затем, начиная с 1966 года, в версии 2+2. Производство кузова купе окончательно прекратилось, начиная с выпуска серии 3 (1971-1975 гг.). Серия 1 характеризуется обтекаемыми фарами, полу-бамперами и приборной панелью «авиационного типа».

Jaguar участвовал в соревнованиях, в частности, за рулем этого автомобиля в 1962 году сидел Бриггс Каннингэм, которому помогал Рой Сальвадори (4е место в гонке Ле-Ман), а в 1963-м – Боб Гроссман (9е место).

После своего появления Jaguar E стал самым быстрым в мире производственным автомобилем, развивая скорость до 250 км/ч. Было произведено более 72500 экземпляров.

В 2010 году «кошачья марка» отпраздновала свою 75-ю годовщину, которая повсеместно отмечалась в клубах коллекционеров.

ХАРАКТЕРИСТИКИ

База	: 243 см
Колея передняя / задняя	: 126 см
Длина	: 437 см
Ширина	: 162 см
Двигатель	: 6-цилиндровый, 9,8 литров
Мощность	: 265 л.с.
Подвеска	: колеса с независимой подвеской
Тормозная система	: Dunlop саморегулирующаяся на 4 колесах
Шины	: Dunlop 16 x 45
Максимальная скорость	: 255 км/ч

E

El Jaguar E-type hizo su aparición en 1961 en el salón del automóvil de Ginebra. Sería el sucesor del modelo XK120, lanzado al mercado doce años antes. Tras los dos primeros prototipos (cabriolés biplaza), Jaguar desarrollaría el E1A (A como abreviatura de aluminio). El vehículo poseía un motor de seis cilindros y estaba disponible en carrocerías tipo cupé o cabriolé. Más tarde, en 1966, se incluiría la carrocería tipo 2 cuerpos. El modelo biplaza cupé dejaría definitivamente de fabricarse a partir de la serie 3 (1971 a 1975). La serie 1 se caracteriza por sus faros integrados en la carrocería y protegidos por una cubierta transparente, parachoques divididos en dos secciones y un tablero de instrumentos de "estilo aeronáutico".

El Jaguar participó activamente en competiciones automovilísticas; en particular, de la mano del piloto Briggs Cunningham y copiloto Roy Salvadori en 1962 (4ª posición en Le Mans) y del piloto Bob Grossman en 1963 (9ª posición).

En el momento de su lanzamiento, el Jaguar E-type era el vehículo de serie más rápido del mundo, rondando una velocidad de 250 km/h. Llegaron a fabricarse más de 72 500 unidades.

En 2010, marca del felino cumplirá su 75 aniversario, que será celebrado por clubes de coleccionista de todo el mundo.

CARACTERÍSTICAS

Distancia entre ejes	: 243 cm
Distancia entre ruedas delante y atrás	: 126 cm
Longitud	: 437 cm
Ancho	: 162 cm
Motor	: seis cilindros, 3,8 litros
Potencia	: 265 HP
Suspensión	: independiente en las cuatro ruedas
Frenos	: Dunlop de disco para cada rueda
Neumáticos	: Dunop 6,40 x 15 RS5
Velocidad máxima	: 255 km/h

NL

De Jaguar type E werd in 1961 voor het eerst voorgesteld op het salon van Genève. Ze volgde de twaalf jaar oudere XK120 op. Na de twee eerste prototypes, die cabriolets met twee plaatsen waren, ontwikkelde Jaguar de E1A (A voor aluminium). De wagen was uitgerust met een motor van zes cilinders en kwam als coupé of cabriolet, en vanaf 1966 als 2+2, op de markt. De coupé met twee plaatsen werd vanaf de serie 3 (1971-1975) niet langer gebouwd. De serie 1 kenmerkte zich door de gestroomlijnde koplampen, de halve bumper en een "vliegtuig" dashboard.

De Jaguar nam deel aan wedstrijden, met in het bijzonder Briggs Cunningham aan het stuur en bijgestaan door Roy Salvadori in 1962 (4e in Mans) en door Bob Grossman in 1963 (9e).

Toen de Jaguar type E op de markt kwam was ze de snelste productiewagen ter wereld, met snelheden tot 250 km/u. Er werden meer dan 72500 stuks gebouwd.

In 2010 heeft het merk met de wilde kat haar vijenzevenstigste verjaardag gevierd en is ze vermaard bij verzamelaars over de hele wereld.

EIGENSCHAPPEN

Wielbasis	: 243 cm
Voor en achter spoor	: 126 cm
Lengte	: 437 cm
Breedte	: 162 cm
Motor	: zes cilinders, 3,8 liter
Vermogen	: 265 PK
Ophanging	: onafhankelijk voor vier wielen
Remmen	: Dunlop met schijf voor elk wiel
Banden	: Dunlop 6,40 x 15 RS5
Maximale snelheid	: 255 km/u

P

O Jaguar type E apareceu em 1961 no Salão de Genebra. Ele sucedeu ao XK120, doze anos mais velho. Após os dois primeiros protótipos, que eram descapotáveis de dois lugares, a Jaguar desenvolveu o E1A (A de alumínio). O automóvel tinha um motor de seis cilindros, dividido em coupé ou cabriolet, depois em 2+2 a partir de 1966. O coupé de dois lugares foi definitivamente abandonado a partir da série 3 (1971-1975). A série 1 caracteriza-se por faróis afunilados, meios pára-choques e um painel de instrumentos do tipo "aviação".

O Jaguar foi usado em competição, nomeadamente com Briggs Cunningham ao volante, assistido por Roy Salvadori em 1962 (4ª em Mans), e em 1963 (9ª) com Bob Grossman.

Quando saiu, o Jaguar type E era o automóvel de produção mais rápido do mundo, roçando os 250 km/h. Foram construídos mais de 72.500 exemplares.

Em 2010, a marca do felino festejou o seu septuagésimo quinto aniversário e foi celebrado em todo o lado, nos clubes de colecionadores.

CARACTERÍSTICAS

Distância entre eixos	: 243 cm
Eixo dianteiro e traseiro	: 126 cm
Comprimento	: 437 cm
Largura	: 162 cm
Motor	: 6 cilindros, 9,8 litros
Potência	: 265 cv
Suspensão	: Rodas independentes
Freios	: Disco Dunlop nas 4 rodas
Pneus	: Dunlop 16 x 45
Velocidade máxima	: 255 km/h

I

La Jaguar E-Type fece il suo debutto nel 1961, al Salone di Ginevra. Sostituì la XK120, di dodici anni più vecchia. Dopo i due primi prototipi, delle cabriolet a due posti, la Jaguar sviluppò la E1A (A come alluminio). La vettura montava un motore a sei cilindri e fu declinata in versione coupé e cabriolet, quindi, a partire dal 1966, in versione 2+2. La coupé a due posti fu definitivamente abbandonata a partire dalla serie 3 (1971-1975). La serie 1 è caratterizzata da fari carenati, semi paraurti e un cruscotto "da aviazione".

La Jaguar partecipò a diverse competizioni, in particolare con Briggs Cunningham al volante assistito da Roy Salvadori nel 1962 (4° a Le Mans), e nel 1963 (9°) con Bob Grossman.







Alla sua uscita, la Jaguar E-Type era la vettura turismo più veloce del mondo, sfiorando i 250 km/h. Furono costruiti oltre 72 500 esemplari.

Nel 2010, il marchio del giaguaro rampante ha festeggiato il suo settantacinquesimo anniversario, celebrato ovunque dai collezionisti.

CARATTERISTICHE

Interasse	: 243 cm
Carreggiata anteriore e posteriore	: 126 cm
Lunghezza	: 437 cm
Larghezza	: 162 cm
Motore	: 6 cilindri, 3,8 litri
Potenza	: 265 CV
Sospensione	: indipendente per le 4 ruote
Freni	: Dunlop a disco per ogni ruota
Pneumatici	: Dunlop 6,40 x 15 RS5
Velocità massima	: 255 km/h

PEINTURES ESSENTIELLES / ESSENTIAL PAINTS

- | | | | | | |
|---|--|---|---|--|--|
| 
9
Marron clair brillant
Gloss Tan
Glänzend-Holzbraun | 
11
Argent
Silver
Silber | 
22
Blanc brillant
Gloss white
Glänzend-Weiss | 
53
Gris métallique
Gunmetal
Metallgrau | 
85
Noir satiné
Satin black
Seidenmatt-Schwarz | 
127
Gris satiné
Satin grey
Satin Grau |
|---|--|---|---|--|--|

PEINTURES COMPLEMENTAIRES / ADDITIONAL PAINTS

Disponibles séparément chez votre revendeur de maquettes. / Available separately at you local hobby shop.

- | | | | | | | |
|--|--|---|--|---|--|--|
| 
21
Noir brillant
Gloss black
Glänzend-Schwarz | 
33
Noir mat
Matt black
Matt-Schwarz | 
56
Aluminium
Aluminium
Aluminium | 
62
Cuir mat
Matt leather
Matt-Leder | 
66
Gris olive mat
Matt olive drab
Matt-Olivgrün | 
321
Rouge transparent
Clear red
Durchsichtiges Ro | 
322
Orange transparent
Clear orange
Durchsichtiges Orange |
|--|--|---|--|---|--|--|

1  **x4**

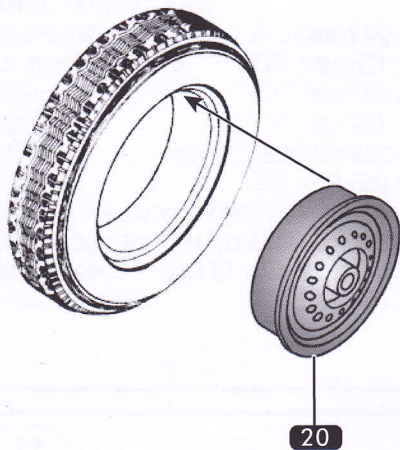

20

2 

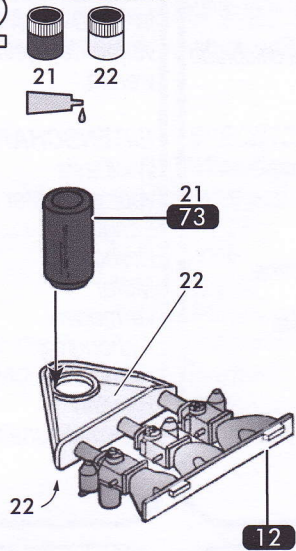

21 22

73

22

12

3 

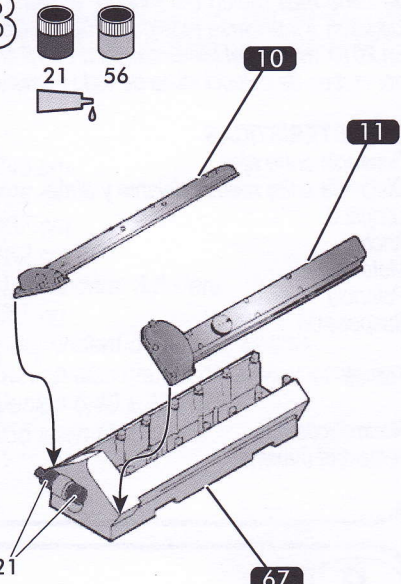

10

11

21 56

21

67

4 

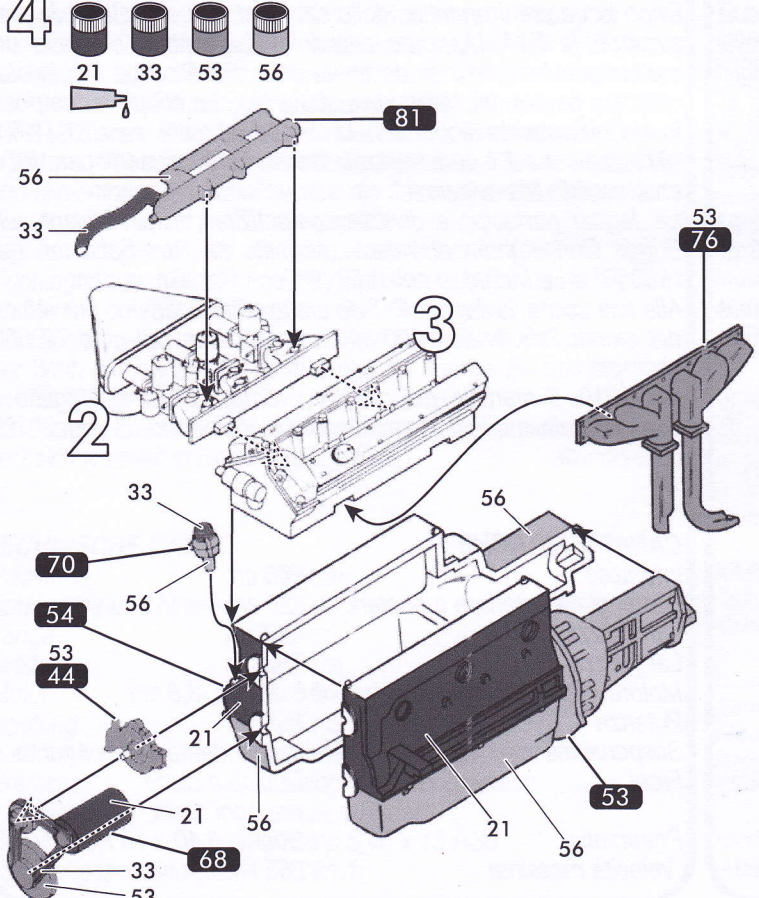

21 33 53 56

81

56

33

53 76

3

70

54

56

53

44

21

56

21

56

53

68

33

53

5 

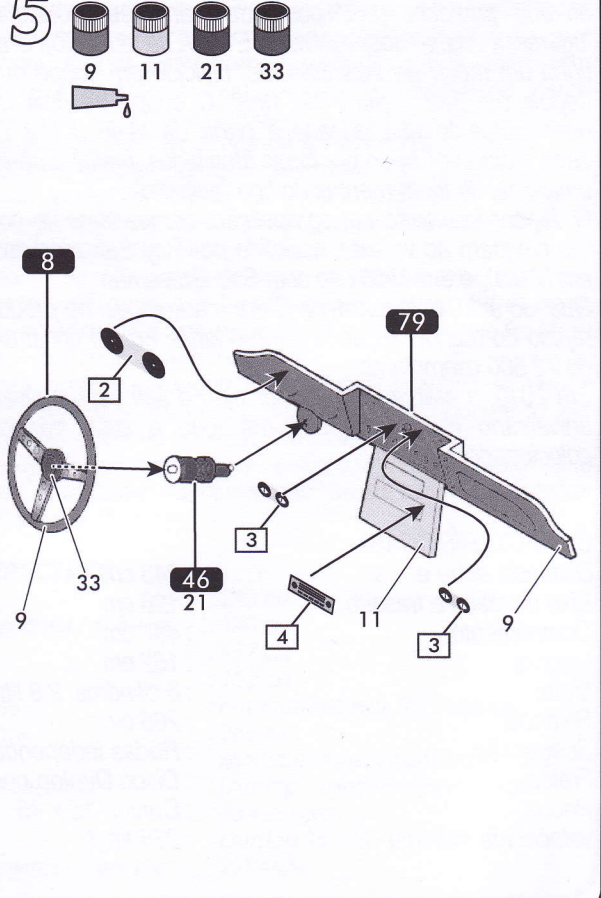

9 11 21 33

8

2

9 33

46

21

3

79

11

3

9

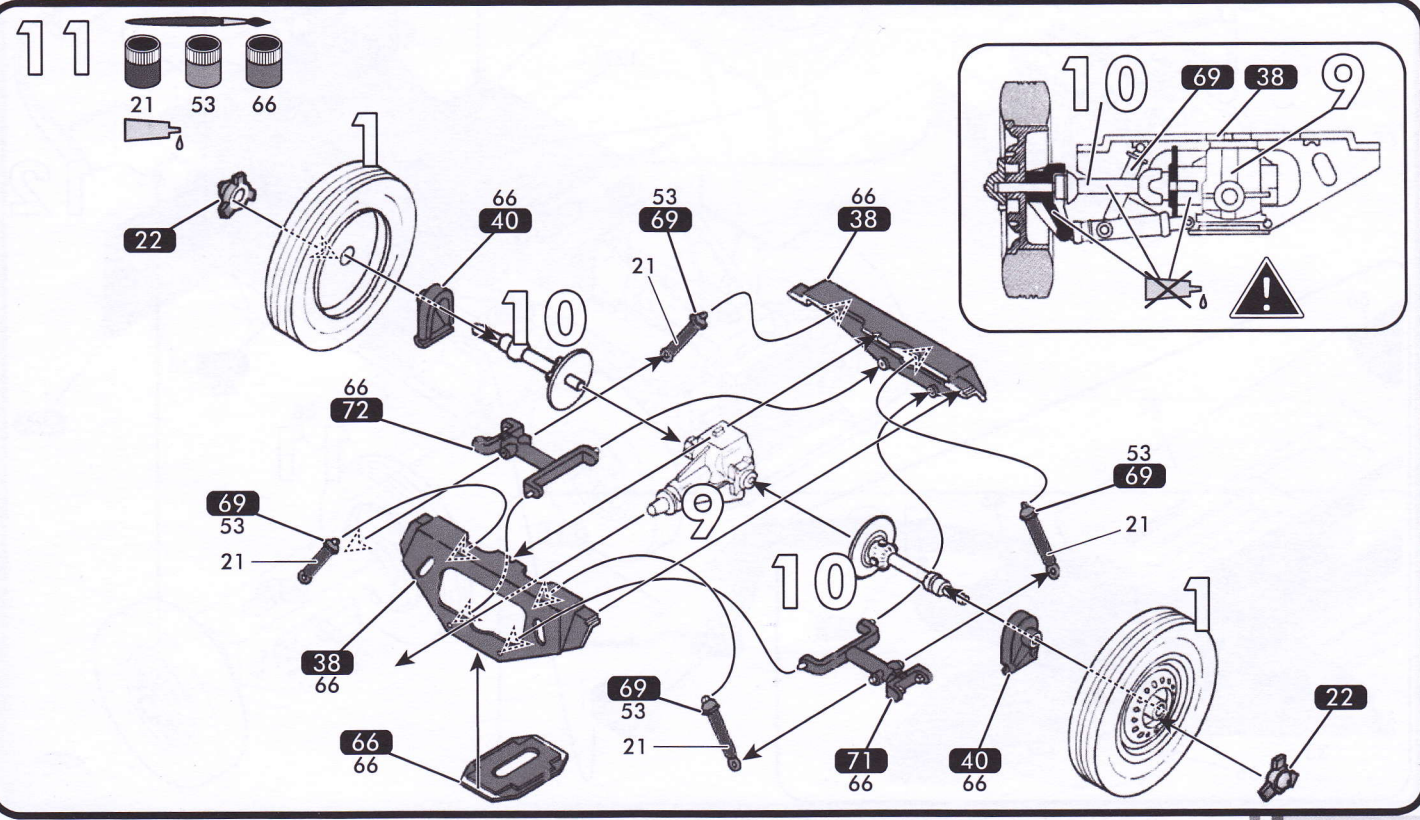
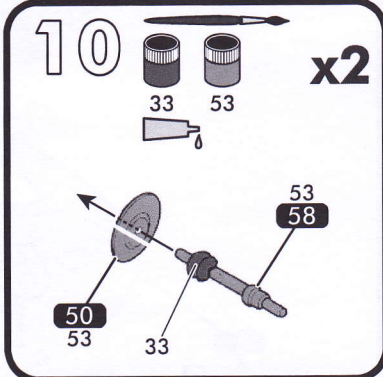
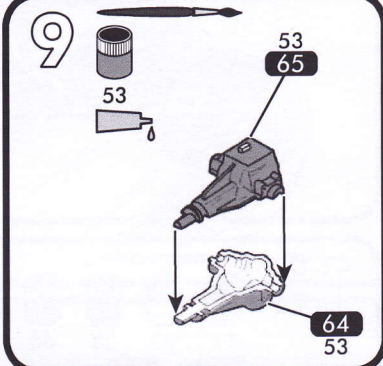
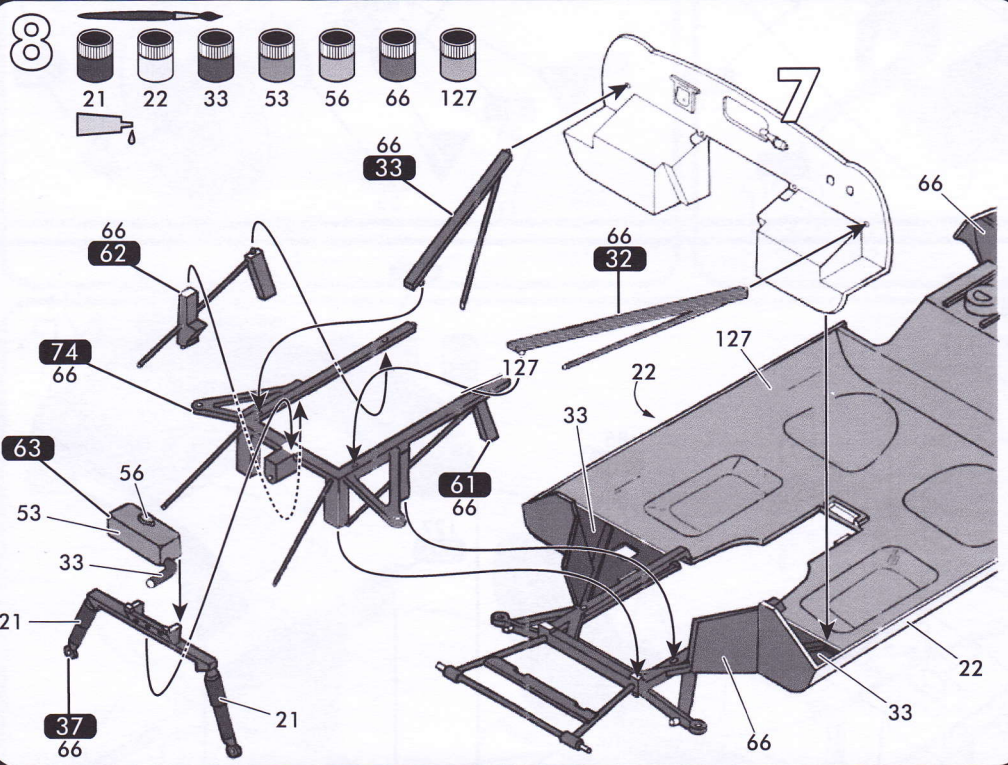
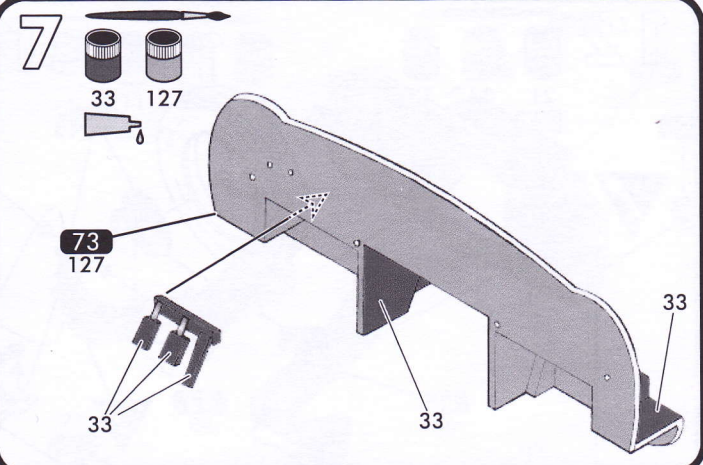
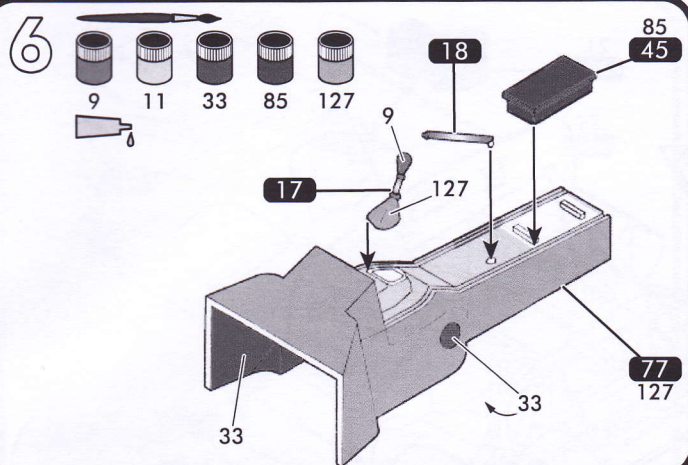

12

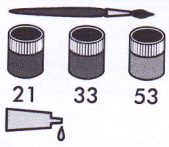

Riveter
To rivet
Nieten
Remachar

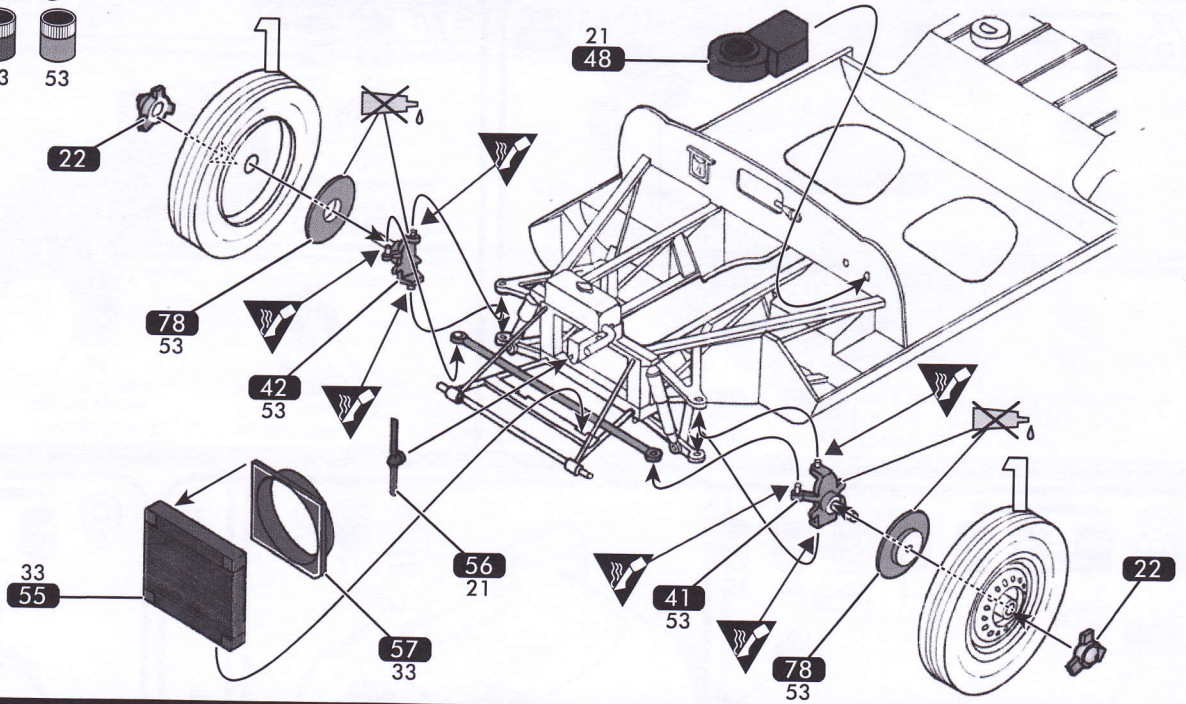

13

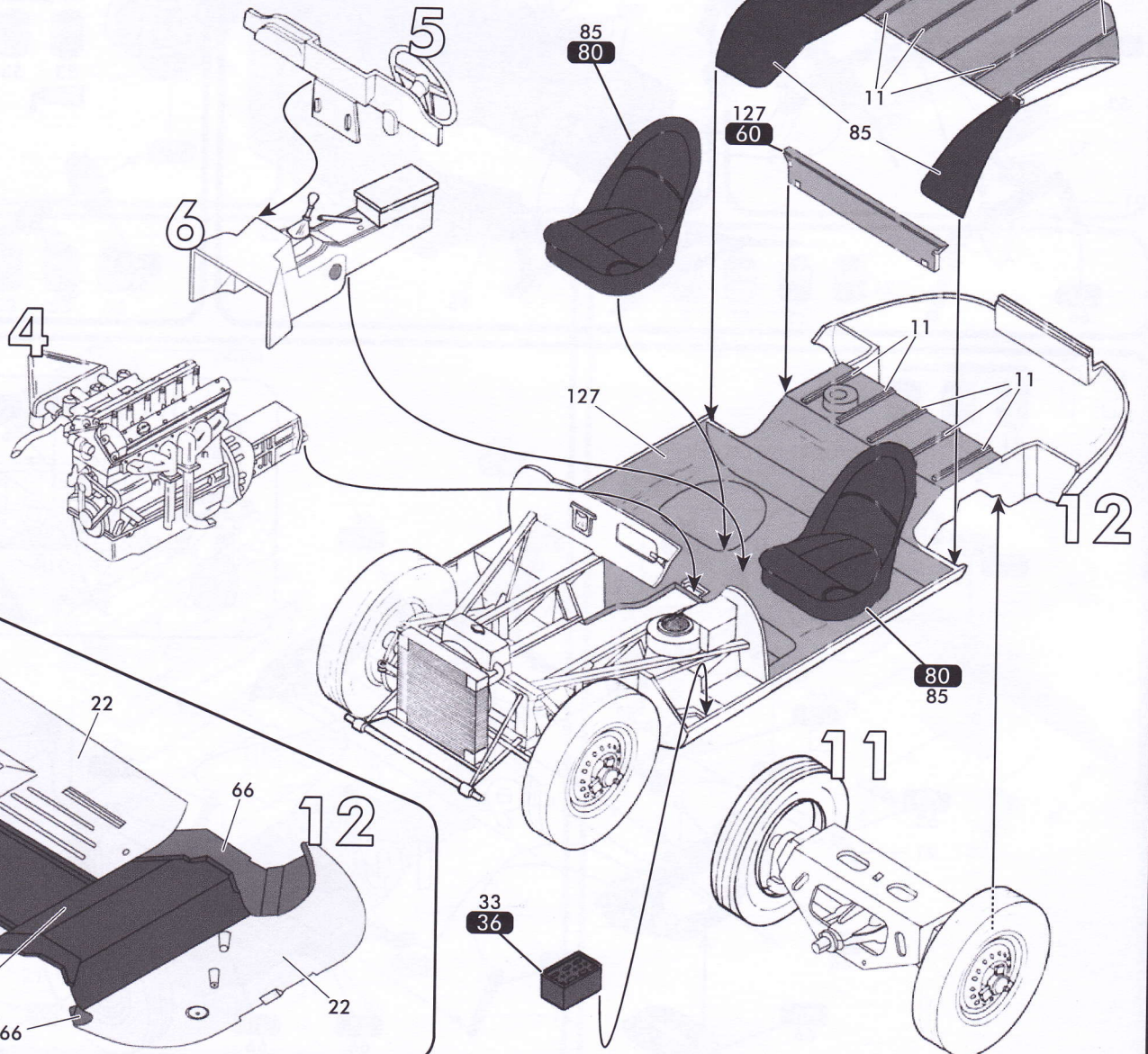
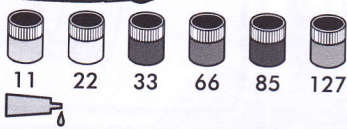

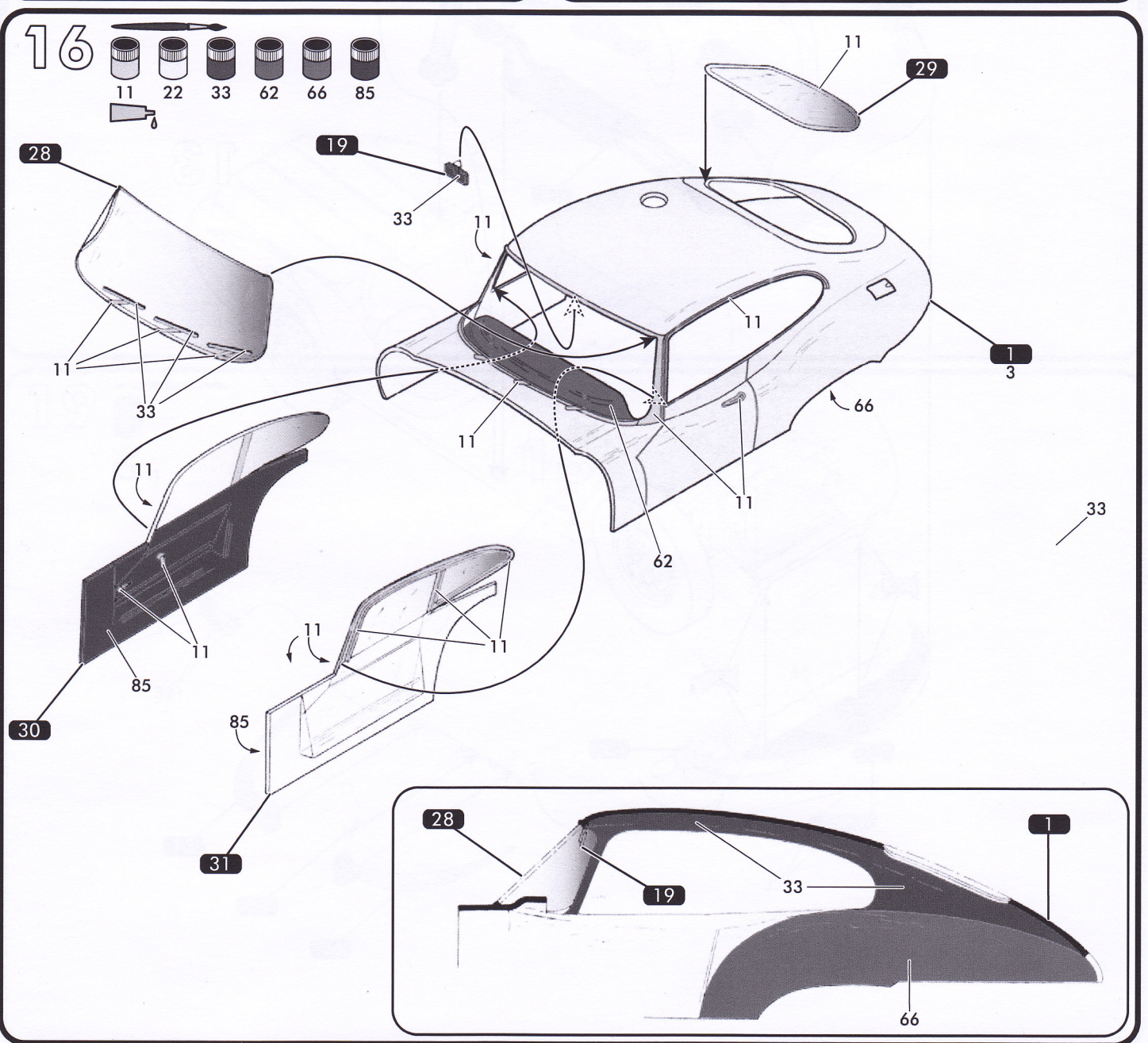
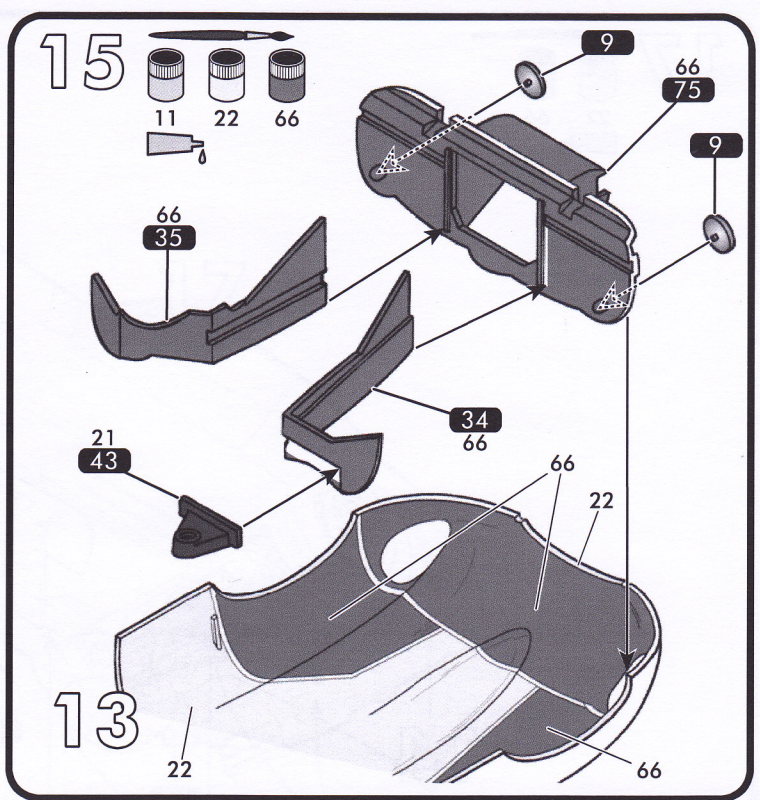
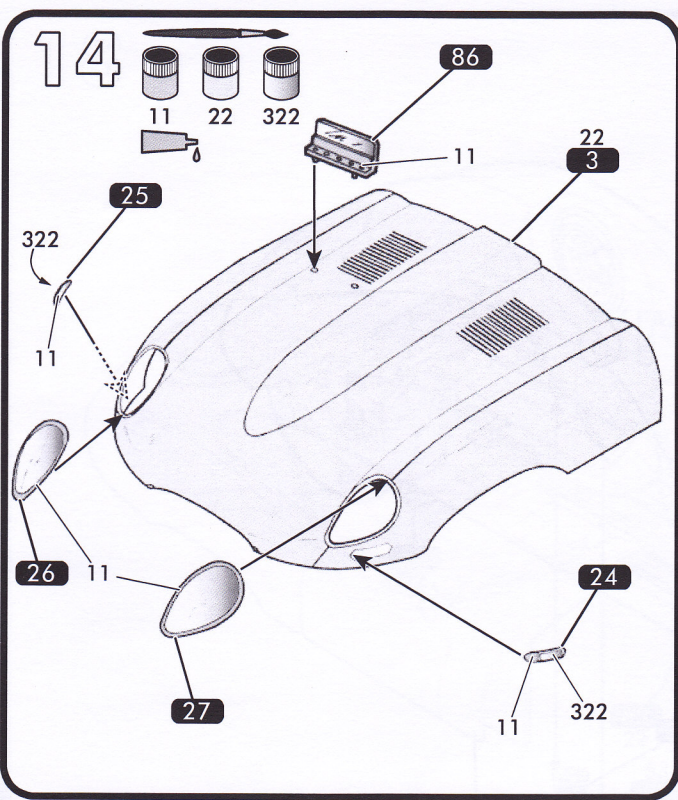

17

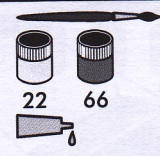

22 66

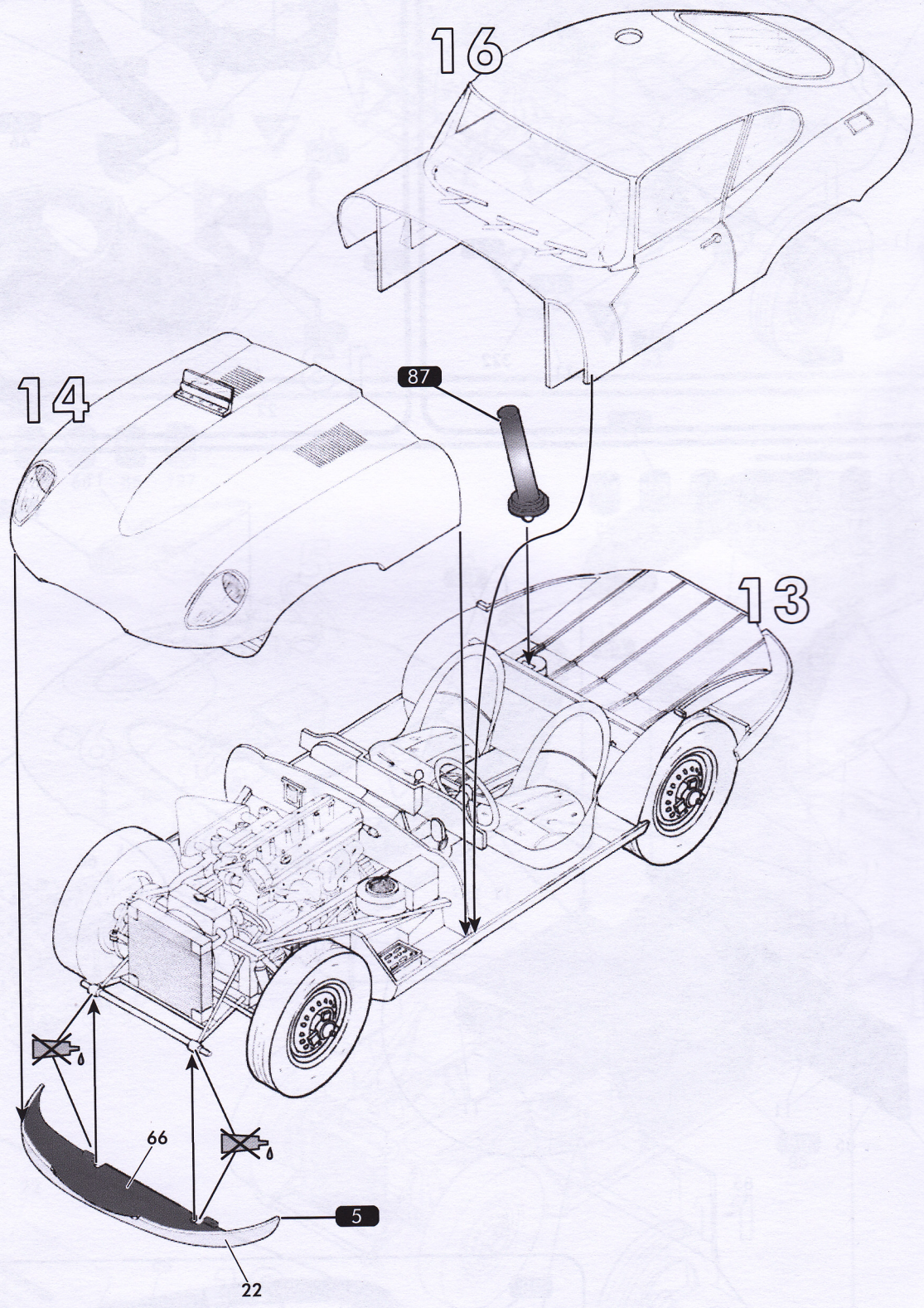

18

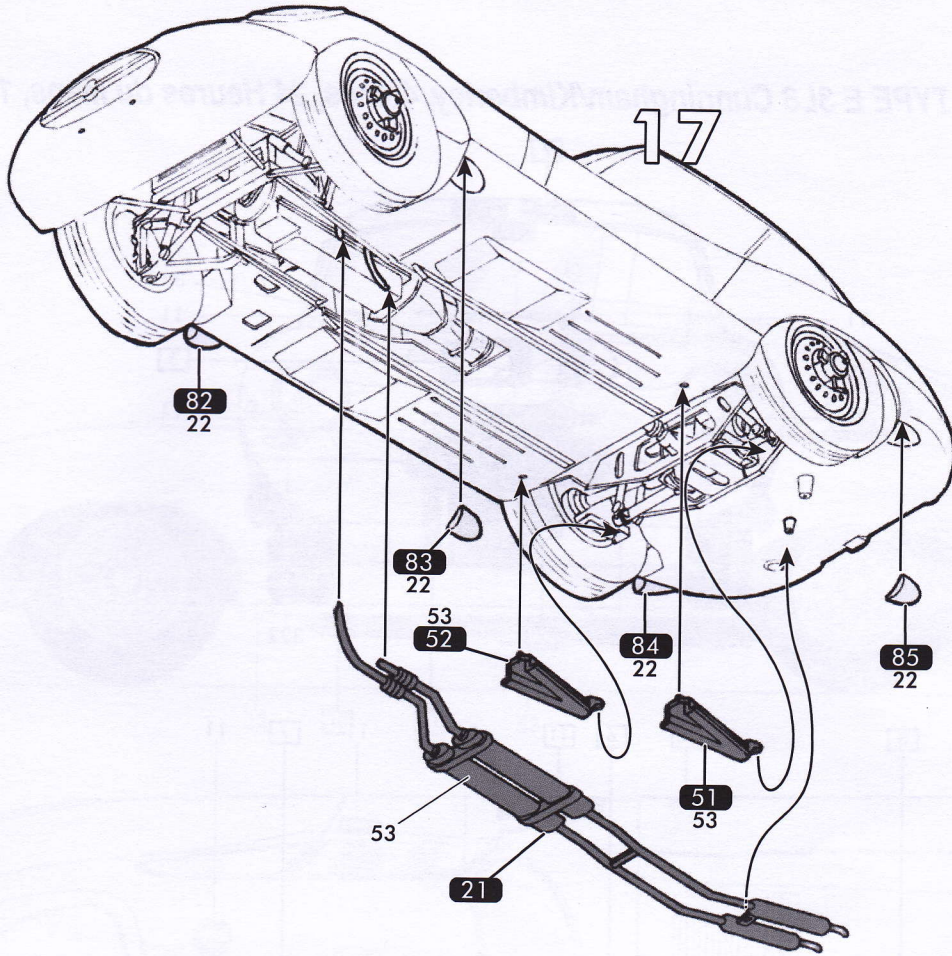
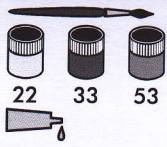

19

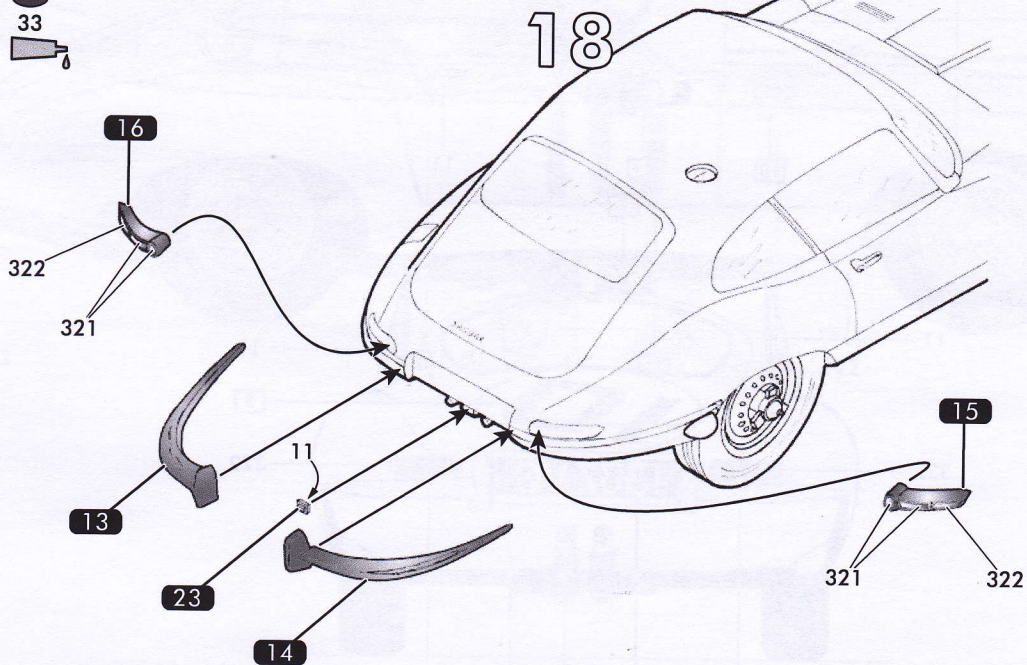
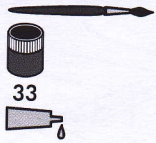

20

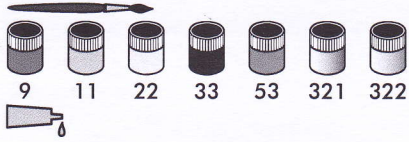

JAGUAR TYPE E 3L8 Cunningham/Kimberley, 4èmes, 24 Heures du Mans, 1962

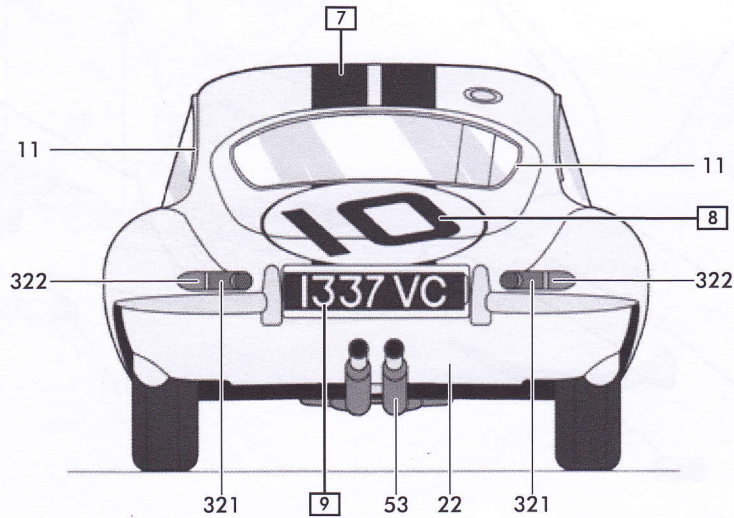
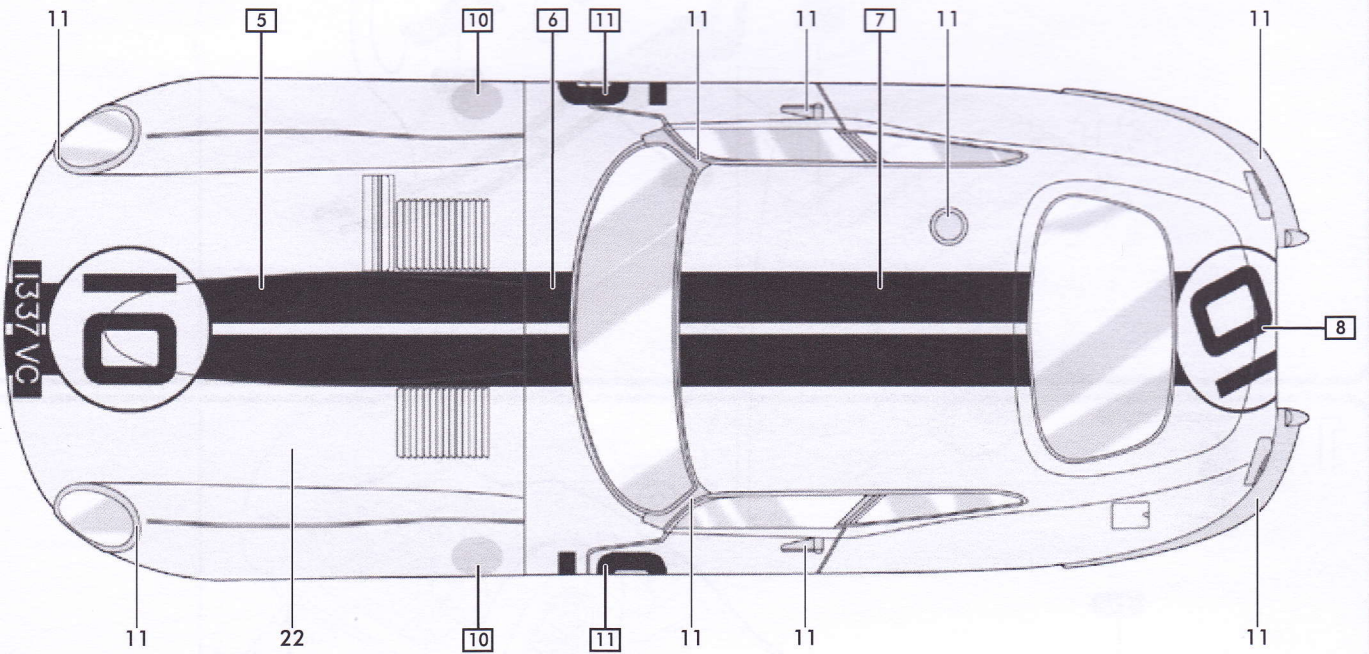
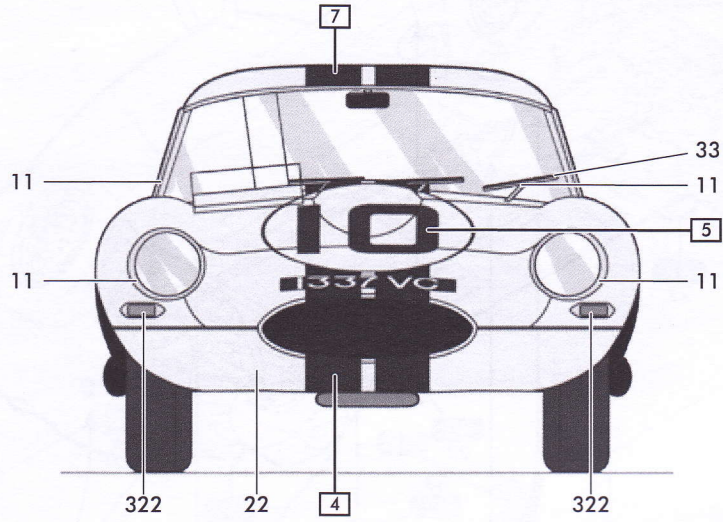

20

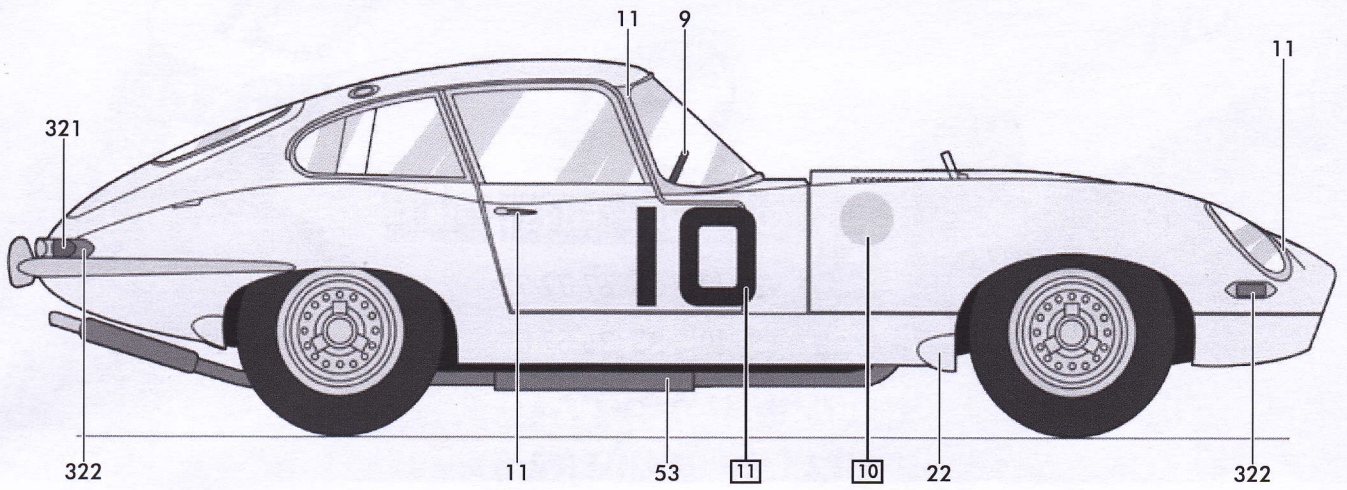
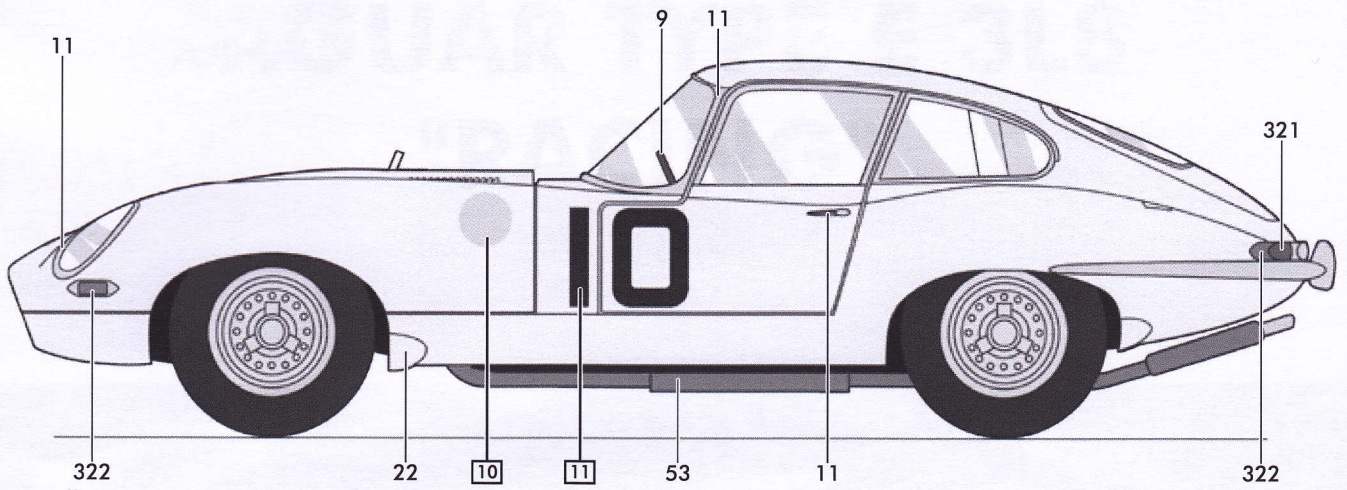
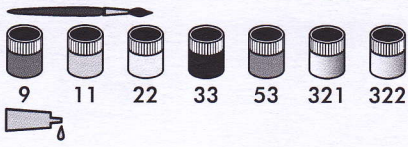

JAGUAR TYPE E 3.6 Coupé (RHD) Kinodromy, Janvier 24 (Paris) du Monde, 1962

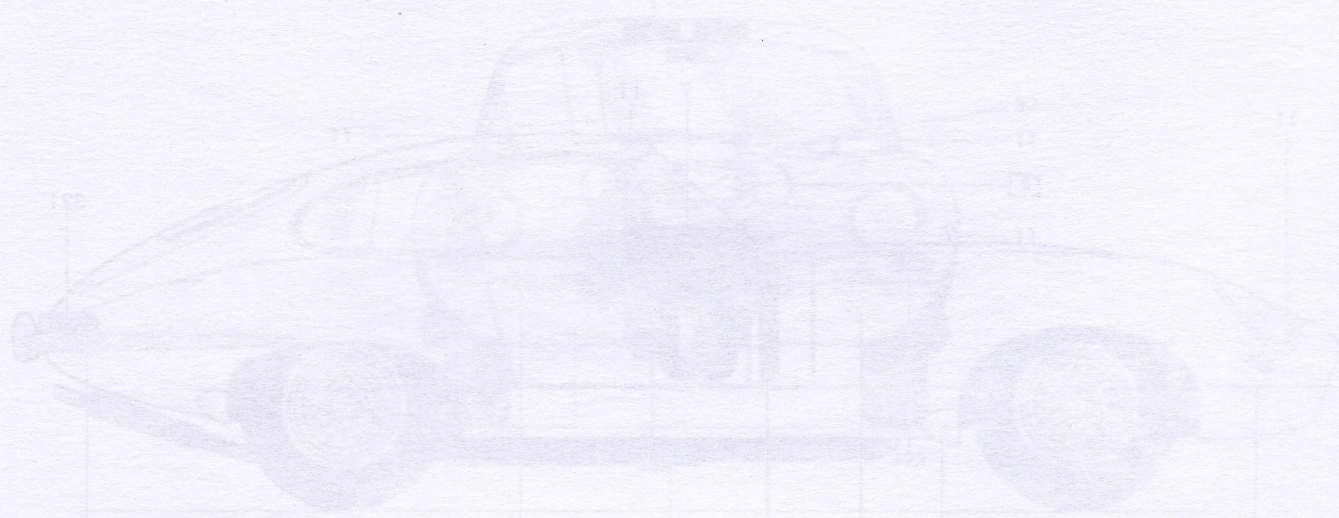

SERVICE CONSOMMATEURS 



+33 (0)2 33 67 72 72



+33 (0)2 33 36 57 07

www.heller.fr

HELLER JOUSTRA SA

Chemin de la Porte

61160 - TRUN

FRANCE



Fabriqu  en France