

Ferrari 312T4

1:12 SCALE Length 378 mm
Width 177 mm
Height 83 mm

- SUPER DETAILED FLAT 12 BOXER ENGINE
- MOVABLE FRONT & REAR SUSPENSION
- SEMI PNEUMATIC RUBBER LIKE TYRES
- DETACHABLE COWLING

BIG SCALE 23 ★ ★ **TAMIYA**
TAMIYA PLASTIC MODEL CO.
626, OSHIKA, SHIZUOKA-CITY, JAPAN.



The reproduction of this model is authorized by Ferrari
La riproduzione di questo modello è autorizzata Ferrari

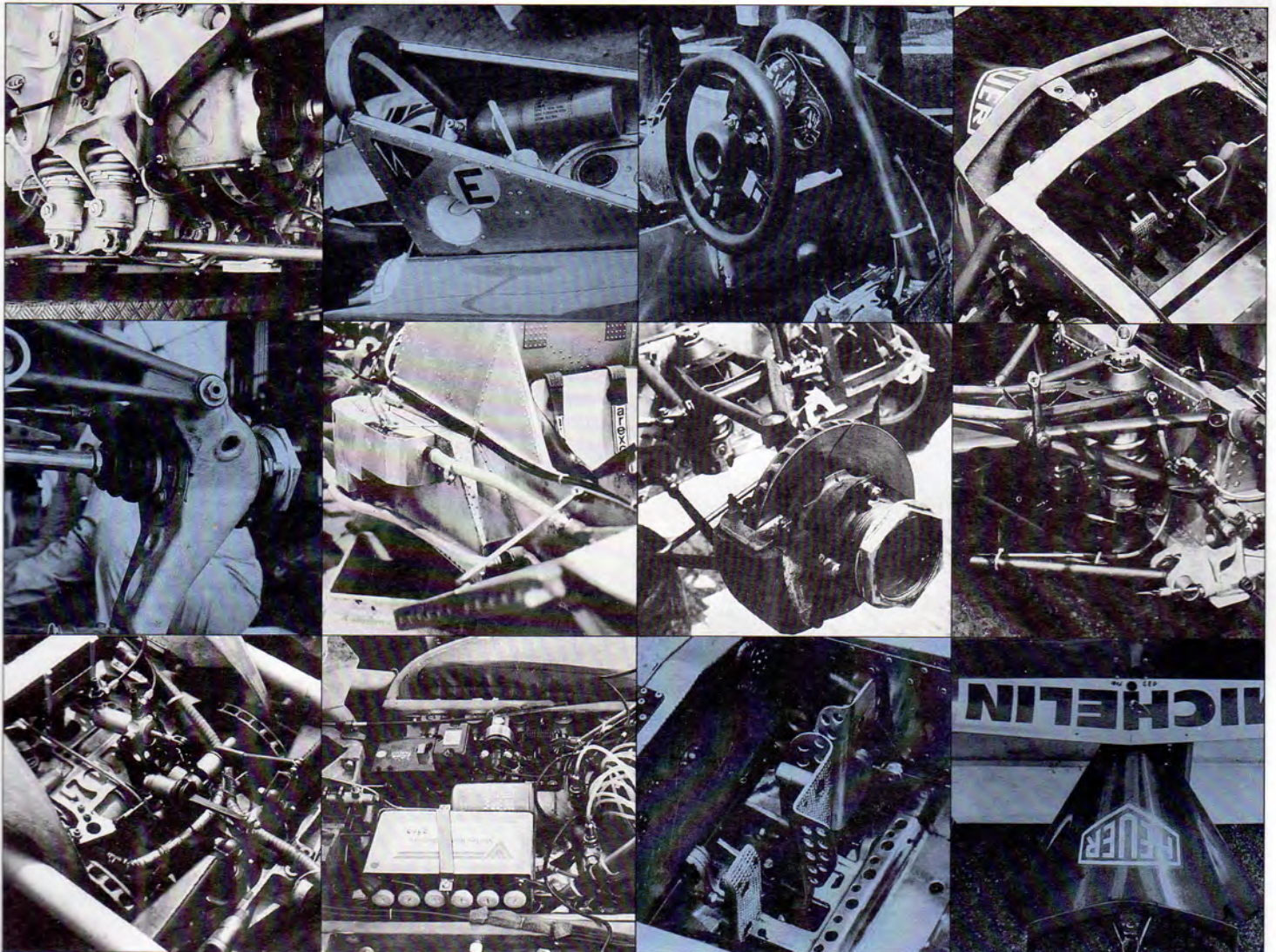

Ferrari 312T4



F1 Grand Prix races for cars with 3 litre engines were held for the first time in 1966. The Lotus 72 and McLaren M23 held dominant positions for several seasons, but with increased performance of the cars through technical improvements, no one car has been able to lead this class. 1979 was no exception. The first two races were won by Ligier with their new JS-11 and it seemed as if perhaps Ligier would have the ascendancy throughout the season, but then the Ferrari 312T4 began winning. By the middle of the season, however, the Renault, equipped with a 1.5 litre turbo engine, began to show overwhelming speed and, at the same time, the FW-07 Williams was not often beaten. After a very exciting season with many changes in the leadership of the Championship tables, it was finally won by Jody Scheckter driving the Ferrari 312T4, which had proved a very reliable machine throughout the whole 1979 season.

Enzo Ferrari, who had been driver and manager for the Alfa Romeo team, started to manufacture racing cars in 1939 and since then he has gained many victories, the first being in the 1949 Grand Prix. Ferrari dominated the F1 class in 1952 and 1953. Many of its drivers have become champions whilst driving for the Ferrari Team: Juan Manuel Fangio in 1956, Mike Hawthorn in 1958, Phil Hill 1961 and John Surtees in 1964. After these early victories the Ferrari Team were not so successful and in 1967 and 1969 they were not to have one win. In 1970 the Ferrari 312B was completed. It had an entirely new horizontally opposed 12-cylinder engine and in the latter half of the season began to show its potential and, with Jacky Ickx or Clay Regazzoni driving, the team notched up four victories and came close to winning the Championship. 1971 started off well for Ferrari, but unfortunately the car did not show its expected performance throughout the season. 1973 proved to be a disaster for the team, but in 1974 with the 312B3 the Ferrari Team came to the fore again. With Nicky Lauda or Regazzoni at the wheel this new car gained three victories and with the appearance of the 312T in 1975, Ferrari's comeback was complete. The 312T with its unique aerodynamic design won six Grand Prix in 1975, with Lauda becoming the Champion in 1977 and Scheckter the Champion in 1979. Ferrari also won the Constructors' Cup from 1975 to 1977 and in 1979. The Ferrari 312T4 made its debut in the South African Grand Prix held on March 3, 1979 with drivers Jody Scheckter and Gilles Villeneuve. In an astonishing finish Villeneuve won the race with Scheckter finishing second and this first and second finish for a new machine in its debut race was a record in Ferrari's history of Grand Prix racing. In the following US Grand

Prix West, Villeneuve obtained the pole position and won the race with Scheckter again taking second place. Scheckter managed fourth place in the Spanish Grand Prix, but in the Belgian race, after having been placed only seventh in practice, he gained his first victory. In the Monaco Grand Prix, the Ferraris again were triumphant with Scheckter coming first and Villeneuve second. At this half way stage in the Grand Prix Championship Scheckter was leading. In 1979 the Championship was decided according to the total points obtained in the best four races in each half of the season. The opening event of the second half of 1979 saw Ferrari again in second place with Villeneuve at the wheel, but in the following British and German races the results for Ferrari were unsatisfactory with Scheckter only managing fifth and fourth places, but in the Australian Grand Prix Villeneuve finished second. Scheckter added steadily to his Championship points by coming second in the Dutch Grand Prix. On September 9th it was the turn of the Italian Grand Prix and, as is quite often the case, this race could decide the 1979 Championship. Ferraris were on their home ground and the crowd were very volatile in their encouragement of their 'own' team. In practice, Scheckter could only manage third and Villeneuve fifth places for the grid line up. However, by extremely clever driving Scheckter won the race with Villeneuve coming in second, and with this result the 1979 Championship became Scheckter's, to the delight of the Italian crowd. For the first time in thirteen years, Ferrari cars came first and second in front of their home crowd and this all added to the excitement of this unforgettable race. The Ferrari 312T4 continued to do well during the rest of the season with Villeneuve coming second in the Canadian Grand Prix and in the final race he gained his third victory.

Although the car only obtained pole position twice, there were only four retirements during the whole of the season and the strength of the 312T4 lay in its reliability. It is Ferrari's first ground effect car. A ground effect car is one utilizing the venturi effect obtaining a strong down force by regulating and utilizing the air flow under the chassis. The lower surfaces of the wide body sides are wing-shaped so as to form a very narrow space, the 'venturi,' between the lower surfaces and the road surface. Air flowing rearward through the venturi is accelerated. The body sides are provided with skirts of special material and these skirts are close to the road surface thus preventing air from entering the venturi from the sides. The air flows rearward very fast and produces negative pressure in the venturi which in turn gives a down force holding the car body close to the

ground. For a ground effect car it is particularly necessary to provide a large space at the rear air outlet so as not to disturb the air flow. It was because the cam cover portion protruded into the air outlet that the horizontally opposed 12-cylinder engine of the Ferrari was thought to be unsuitable for use in a ground effect car. The unique style of the 312T4, designed on the basis of wind tunnel tests at Pininfarina, Trino, aimed at producing better effect by taking in as much air as possible. The lower surfaces of the side pontoons have delicate curves to increase the venturi effect. The pointed end of the nose cone is provided with a single-piece wing, to increase the ground contact of the front wheels. To mount the engine on the chassis of the 312T4, it has been made narrower by modifying the cam cover and cam shape. The exhaust pipes are tied together three by three, and are bent upward so as not to disturb air flow. The engine is said to have a maximum output of 515 hp. The figures "312" mean three-litre 12-cylinder and the letter "T" stands for transverse, which means that the gearbox developed by Ferrari is mounted transversely behind the engine. The "T" series, which has maintained its high potential since 1975 against such strong rivals as the McLaren and Lotus, is considered to be one of Ferrari's masterpieces. With its aerodynamically designed body, the 312T4 proved in 1979 that it was possible to mount the horizontally opposed 12-cylinder engine on a ground effect car, and it proved worthy of the name Ferrari.

Im Grand Prix erschienen 3 Liter Wagen erstmals 1966. Lotus und McLaren beherrschten zwar einige Saisons die Rennen, aber durch die erhöhte Leistung und die technischen Verbesserungen konnte keiner dieser Wagen die Klasse anführen. Auch 1979 nicht. Die ersten beiden Rennen wurden von Ligier mit dem neuen JS-11 gewonnen und es hatte den Anschein, dass Ligier grossen Einfluss auf die Saison 79 nehmen würde.

Mitte der Saison zeigte Renault mit einem 1,5l Turbomotor überwältigende Geschwindigkeiten und auch der Williams FW-07 war öfters vorne. Nun aber kam Ferrari mit dem neuen 312T4 auf die Soegerplätze.

Nach einer ausgezeichneten Saison und vielem Wechsel in der Führung, wurde Jody Scheckter Weltmeister. Dies zeigte, dass der Ferrari 312T4 ein sehr zuverlässiger Wagen in allen Rennen war. Enzo Ferrari, selbst ein langjähriger Fahrer und Manager des Alfa-Romeo Teams, begann bereits 1939 Rennwagen zu bauen. Seit dieser Zeit konnte er viele Siege erringen, den ersten im Grand Prix 1949. Ferrari beherrschte auch die Formel 1 Klasse in den Jahren 1952 und 1953 und es gingen viele Weltmeister aus seinem Team hervor:

1956 Juan Manuel Fangio—1958 Mike Hawthorn

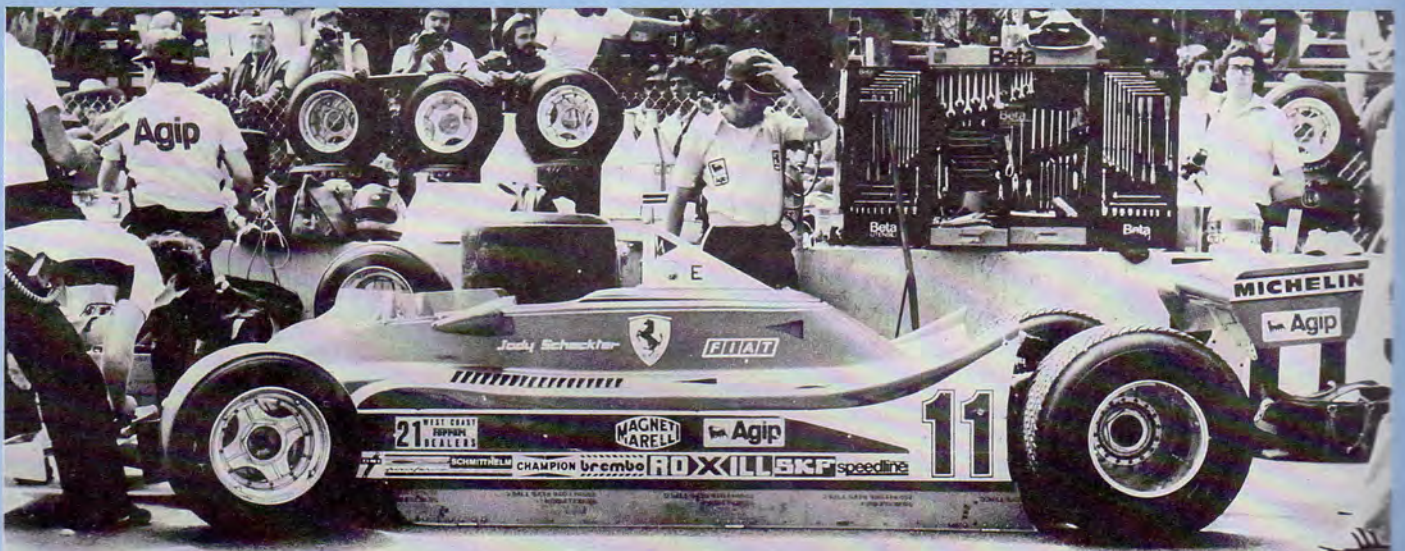

1961 Phil Hill—1964 John Surtees.

Dan kam eine ruhige Zeit für Ferrari—ohne Sieg. Erst 1970 war dann der neue Ferrari 312B einsatzbereit. Der Wagen hatte einen 12 Zylinder-Boxer-Motor.

In der letzten Hälfte der Saison zeigte er seine Stärke und Leistung mit Jacky Ickx und Clay Regazzoni am Steuer. Das Team errang 4 Siege und verfehlte knapp die Meisterschaft.

Das Jahr 1971 liess sich gut an, aber der Wagen brachte nicht die erwartete Ausdauer über die ganze Saison.

1973 lief alles schief, aber 1974 wurde mit dem Ferrari 312B3 der Anschluss erreicht.

Mit Nicki Lauda und Clay Regazzoni konnten 3 Siege verbucht werden. Der 312T jedoch brachte Ferrari sein Comeback.

Mit seiner einmaligen, aerodynamischen Form gewann der 312T 6 Grand Prix 1975.

Nicki Lauda wurde 1977 Weltmeister und Jody Scheckter 1979.

Am 3 März 1979 wurde der 312T4 erstmals im Grand Prix South Africa eingesetzt mit Jody Scheckter und Gilles Villeneuve.

Es war ein einmaliger Sieg für Gilles Villeneuve, Jody Scheckter wurde Zweiter—ein toller Erfolg für Ferrari, mit einem neuem Wagen, gleich die ersten beiden Plätze im ersten Rennen zu belegen.

Dann kamen die Erfolge in dieser Saison:

US Grand Prix West: Villeneuve Erster, Scheckter Zweiter.

Grand Prix Spanien: Scheckter Vierter.

Grand Prix Belgien: Scheckter Erster.

Grand Prix Monaco: Scheckter Erster, Villeneuve Zweiter.

Somit führte Scheckter die Weltmeisterschaft an. Den Eröffnungslauf der 2. Hälfte der Saison führte Ferrari mit Villeneuve wieder als Zweiter an. In den folgenden Rennen in England und Deutschland wurde Scheckter nur 5. bzw. 4., der Grand Prix Australien zeigte Villeneuve wieder als Zweiten. Der 2. Platz für Scheckter im Grand Prix von Holland brachte weiterhin Punkte für die Meisterschaft.

Nun kam am 9. September der Grand Prix Italien. Auf einheimischen Boden belegten Scheckter im Training den 3. Platz, Villeneuve den 5. Platz. Wie so oft, brachte dieser Grand Prix die Entscheidung für die Weltmeisterschaft:

Scheckter wurde Sieger, Villeneuve Zweiter. Und —zur grossen Freude der Italiener, 1979 wurde Ferrari mit Scheckter Weltmeister. Zum ersten Male in 13 Jahren wurde Ferrari Erster und Zweiter

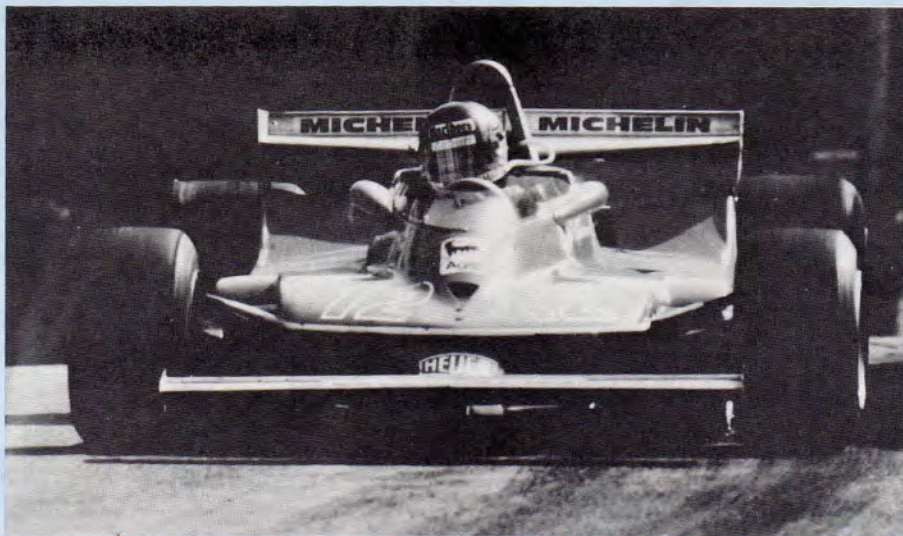

im eigenem Lande. Ein unvergesslicher Sieg und Erfolg.

Im Grand Prix von Kanada wurde Villeneuve Zweiter und im Endlauf errang er seinen 3. Sieg. Nur vier Mal musste der Wagen aus den Rennen zurückgezogen werden, dies zeigt seine Stärke und Ausdauer sowie Zuverlässigkeit.

Der 312T4 ist der erste Wagen von Ferrari mit dem Bodenhaft-Effekt.

Ein Wagen mit Bodenhaft-Effekt erreicht einen starken Druck nach unten durch Regulierung und Verwendung der Luftströmung unter das Chassis. Die untere Fläche der breiten Karoserieseiten sind flügelartig und drücken die Luftströmung zwischen die Unterfläche und Strassenoberfläche. Der Luftstrom kann durch die Windkanäle reguliert werden. Die Karoserieseiten haben Schürzen aus einem Spezialmaterial und liegen fast auf der Strasse auf, dies verhindert, dass von aussen der Luftstrom gestört wird.

Die Luft fliesst sehr schnell nach hinten ab und erzeugt einen Negativdruck im Windkanal, dies wiederum drückt den Wagen sehr stark nach unten. Entworfen wurde der Ferrari 312T4 von Pininfarina auf Grund eingehender Versuche im Windkanal soviel Luft wie möglich herzuführen. Die seitlichen Pontoons haben eine ausgezeichnete Kur-

venführung um den Luftstrom effektiv zu erhöhen. Der Bug des Fahrzeuges ist einer Raketenspitze ähnlich mit einem Flügel zur Erhöhung des Bodenkontaktes der Vorderräder.

Das Chassis wurde schmaler gemacht, um den Motor montieren zu können.

Die Auspuffrohre sind jeweils 3 gebündelt und nach oben gezogen um den Luftstrom nicht zu stören. Der Motor hat eine max. Leistung von 515 HP. Die Zahl 312 sagt, 3 Liter und 12 Zylinder, der Buchstabe "T" bedeutet Transverse (Quer) und zeigt, dass das Getriebegehäuse quer hinter dem Motor angebracht ist.

Die "T" Serie hat sich seit 1975 gegen die starken Rivalen McLaren und Lotus durch höchste Leistung behauptet und ist eine Meisterleistung von Ferrari.

Mit seiner aerodynamischen Karosserie bewies der 312T4, dass es möglich ist, den horizontalen Boxermotor mit 12 Zylindern, in einen Wagen mit Bodenhaft-Effekt einzubauen und für Wert befunden wird, den Namen Ferrari zu tragen.

«Specifications of Ferrari 312T4»

Sponsor(s) Fiat
 Designer(s).....Mauro Forghieri
 Team manager(s)..... Enzo Ferrari
 Marco Piccinini

Number of chassis built.....5

ENGINE

Type Ferrari 312 Boxer
 Fuel and oil Agip
 Sparking plugs Champion

TRANSMISSION

Gearbox/speeds Ferrari 015

Transversale (5)

Drive-shafts Löbro/Ferrari

Clutch Borg & Beck

CHASSIS

Front suspension..... Double wishbones,

inboard springs

Rear suspension Bottom wishbones,

single top links, inboard springs

Suspension dampers Koni

Wheel diameter.....13 in front and rear

Wheel rim widths 11/12/13 in front

18/19 in rear

Tyres Michelin

Brakes Lockheed

Brake pads Ferodo

Steering Ferrari rack and pinion

Radiator(s) Autokhüler

Fuel tanks Pirelli/Superflexit

Battery Varley

Instruments Borletti

DIMENSIONS

Wheelbase 106.3 in/2700mm

Track..... 67 in/1700mm front

63 in/1600mm rear

Gearbox weight 121 lb/55kg

Formula weight 1312 lb/595kg

Fuel capacity.....40.7 gals/185 litres

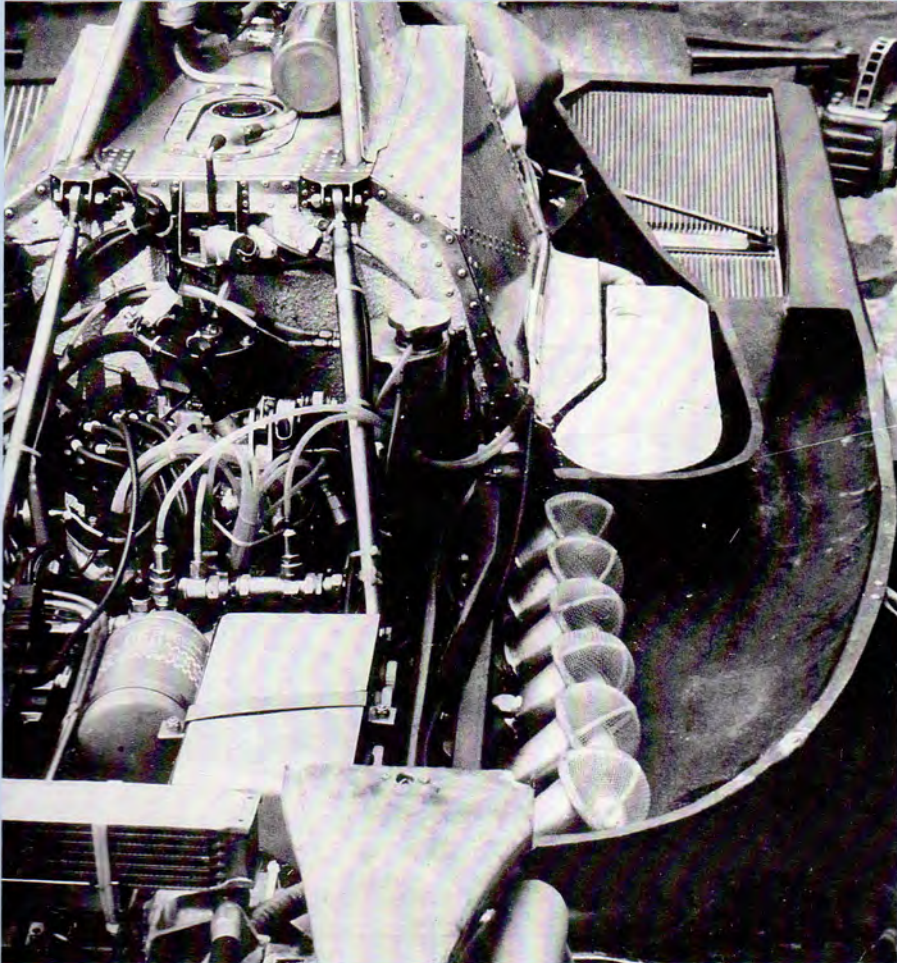

Photos credit SeL and Lucio Maggio

Read before assembly

Erst lesen-dann bauen

- * Study the instructions and photographs before commencing assembly.
- * You will need a sharp knife, a screwdriver, a file and a pair of pliers.
- * Do not break parts away from sprue, but cut off carefully with a pair of pliers.
- * Use cement sparingly. Use only enough to make a good bond.
- * Apply cement to both parts to be joined.

This mark shows the colour.

* Vor Beginn die Bauanleitung studieren und den Nummern nach die Elemente zusammenbauen.

- * Bauteile nicht vom Spritzling abbrechen, vorsichtig abschneiden oder abzwicken, Teil vor Kleben zusammenhalten, auf genauen Sitz achten. Nicht zuviel Klebstoff verwenden. Kleine Teile hält man mit Pinzette fest.
- * Abziehbilder vorsichtig von der Unterlage im Wasser abschieben, auf richtigen Sitz achten und gut trocknen lassen.

Zeichen für Bemalung

Parts to be cemented
hier ankleben

Installation of Vinyl Tubing
Einbau Vinylschlauch

If vinyl tubing is too tight to fit, use a toothpick to open it a little.
Wenn Vinylschlauch zu klein, mit Zahnstocher etwas dehnen.

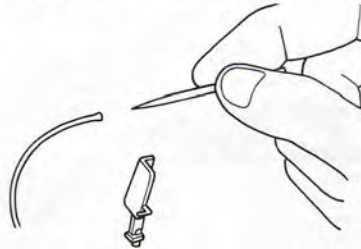

3 Seat Belt Sitz Gürtel

Seat Belts are made from adhesive tape and are self sticking after assembly. Pattern is shown below.
Für Gurte-Klebeband benutzen.

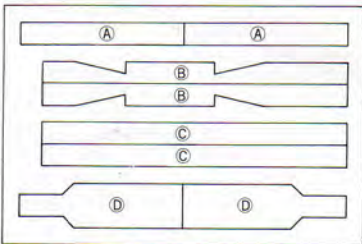

1 Steering Gear Box Lenkgetriebe

Assembly
Montage

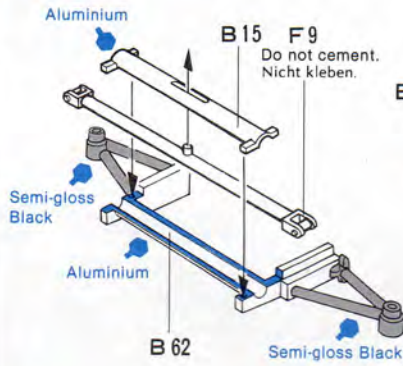

Do not cement.
Nicht kleben.

Installation
Einbau

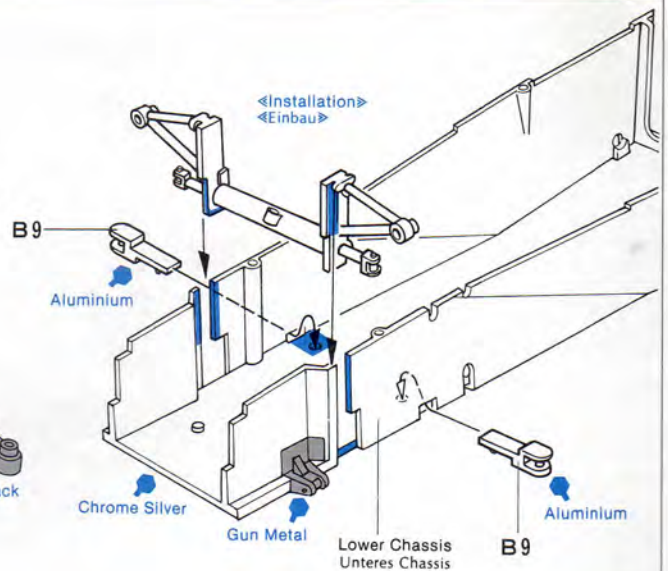

2 Pedal Pedal Assembly Pedalbau

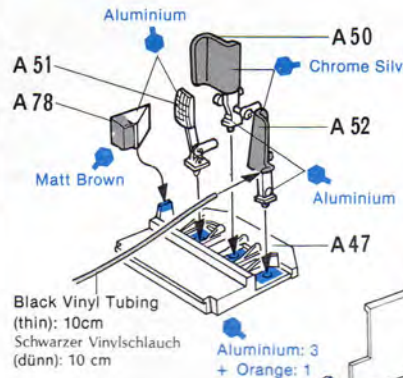

Black Vinyl Tubing (thin): 10cm
Schwarzer Vinylschlauch (dünn): 10 cm

Aluminium: 3 + Orange: 1

C8 Red (Belt: Aluminium)

Upper Chassis
Oberes Chassis

Lower Chassis
Unteres Chassis

Put this tubing in at step 1
Schlauch in Step 1 unter den Sitz legen.

3 Seat Belt Sitz-Gürtel

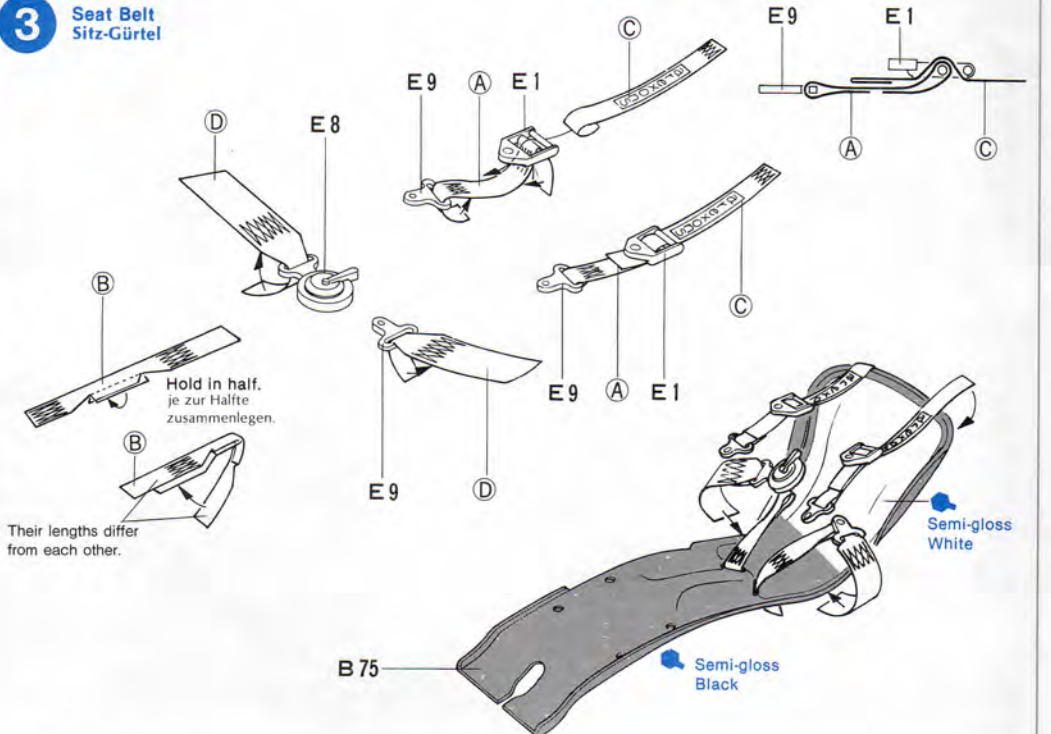

Hold in half, je zur Hälfte zusammenlegen.

Their lengths differ from each other.

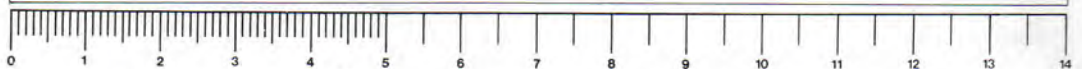

4 «Affixing Seat to Chassis»
«Sitz Einbau»



5 «Inner Parts»
«Innenteile»

«Decals of Meters»
«Abziehbilder der Tacho's»

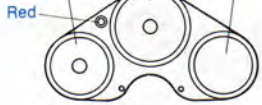

«Switch Panel»
«Schalter-Brett»

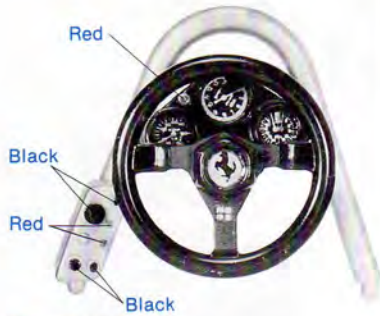

6 «Cockpit»
«Fahrersitz»



4 Affixing Seat to Chassis
Sitz Einbau

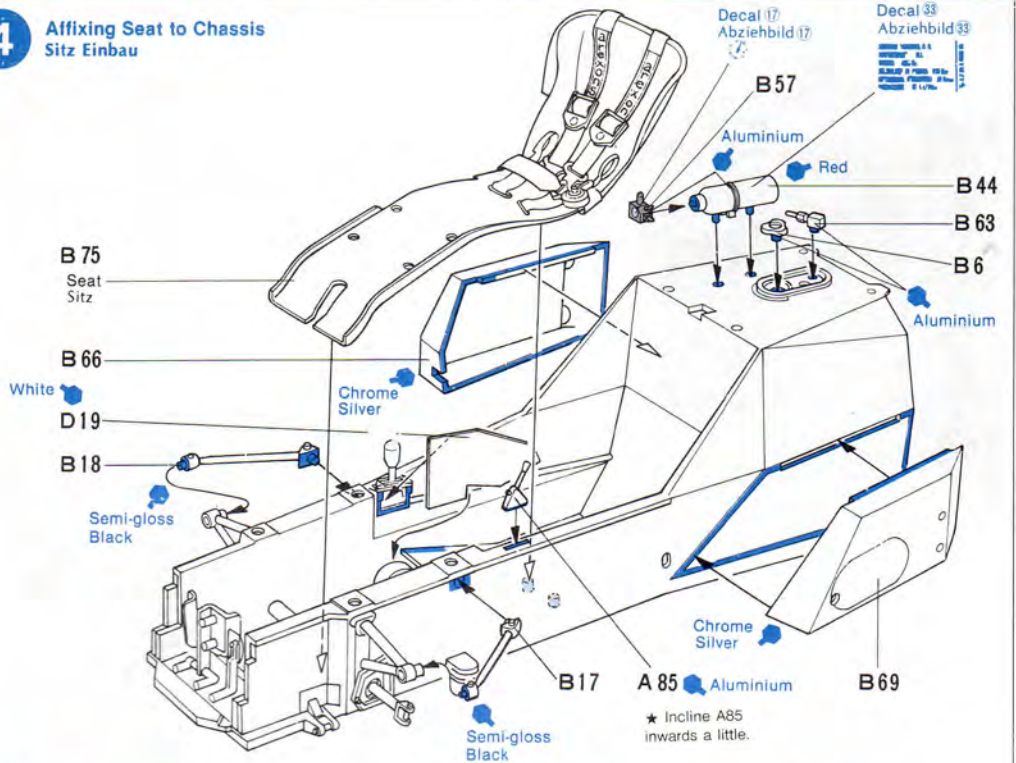

5 Inner Parts
Innenteile

«Front Bulkhead»
«Feuerwand»

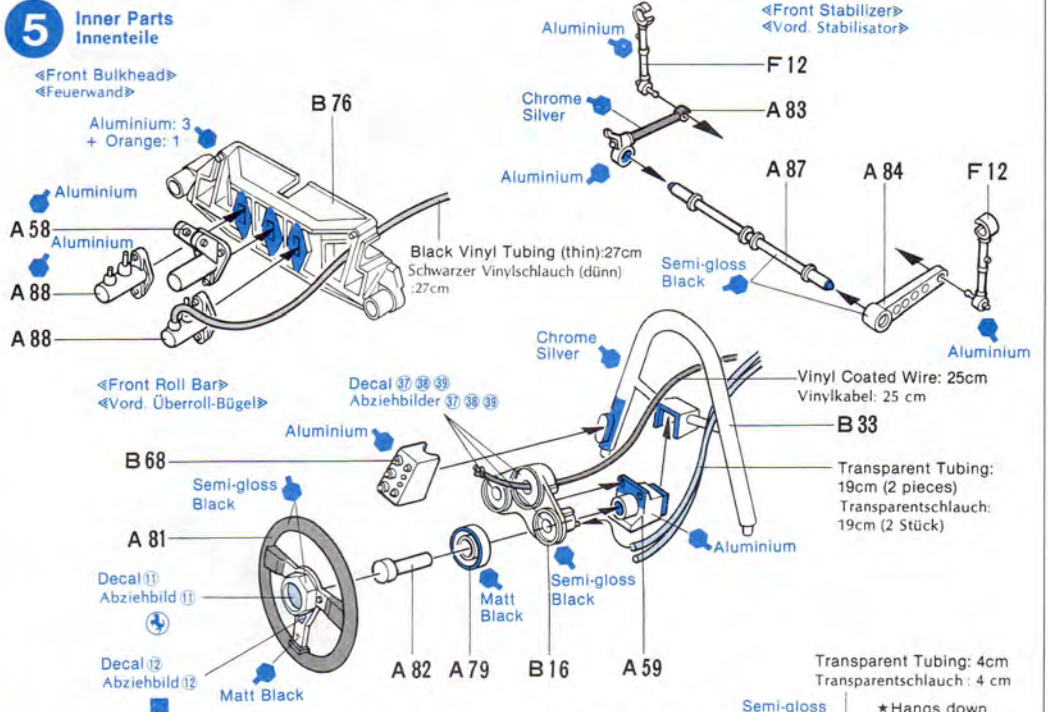

6 Cockpit
Fahrersitz

● : Painting of D20 and D21
● : Bemalung der D20 und D21

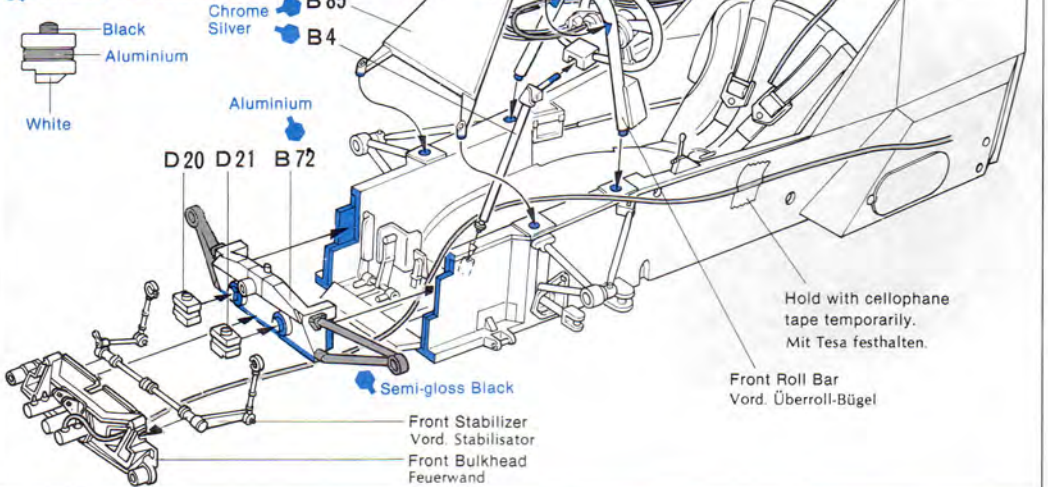

7 <<Engine>>
<<Motor>>

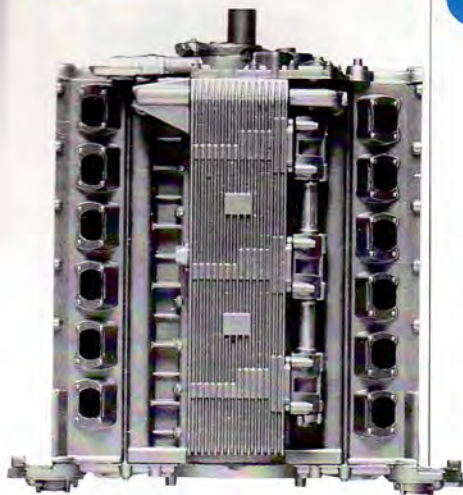

7 Engine
Motor

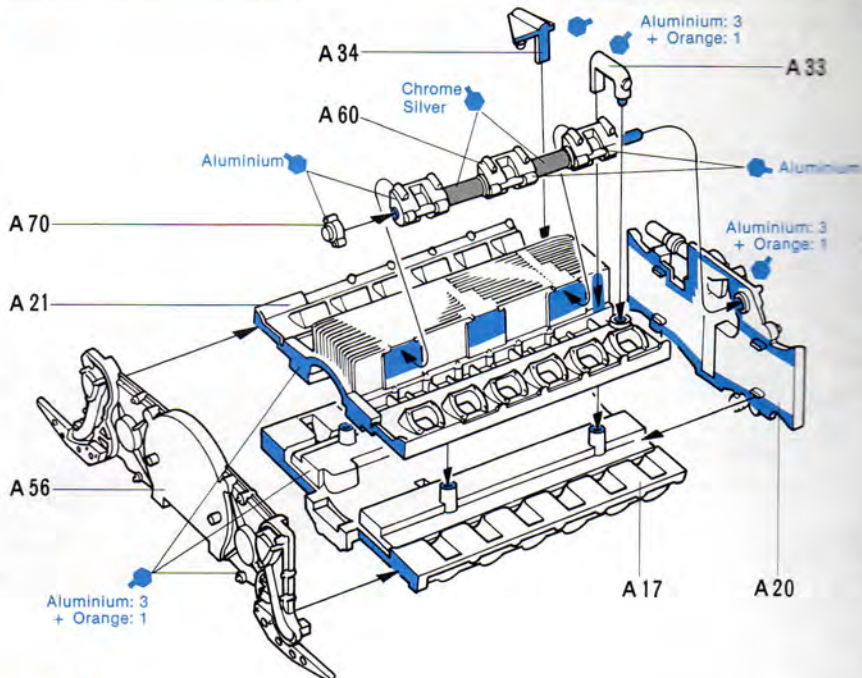

8 <<Fuel Injection Plate>>
<<Einspritz-Anlage>>

Cut the mesh to fit each E7 as shown below.
Das Gitter für E7 wie gezeigt schneiden.

<<Step 1>>

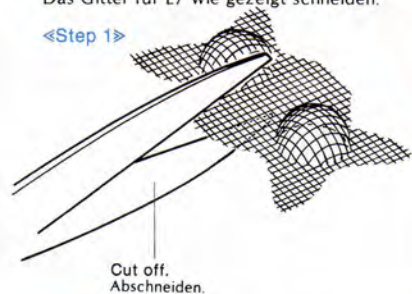

<<Step 2>>



* Before cementing parts, remove plating with a knife, etc. from the surfaces to which adhesive is to be applied.
Chromschicht an Klebestellen entfernen.

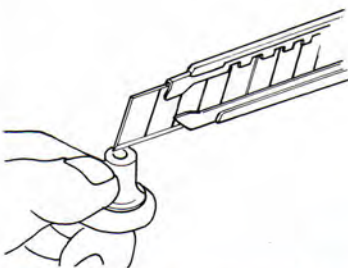

9 <<Attaching Fuel Injection Plate>>
<<Einspritz-Anlage Einbau>>

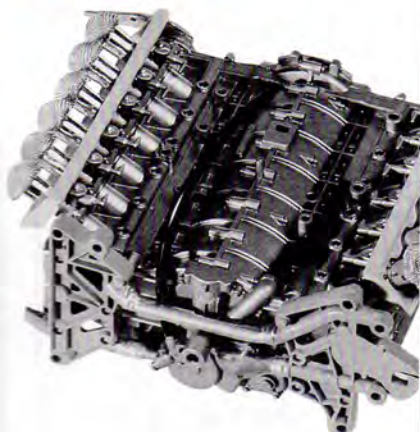

8 Fuel Injection Plate
Einspritz-Anlage

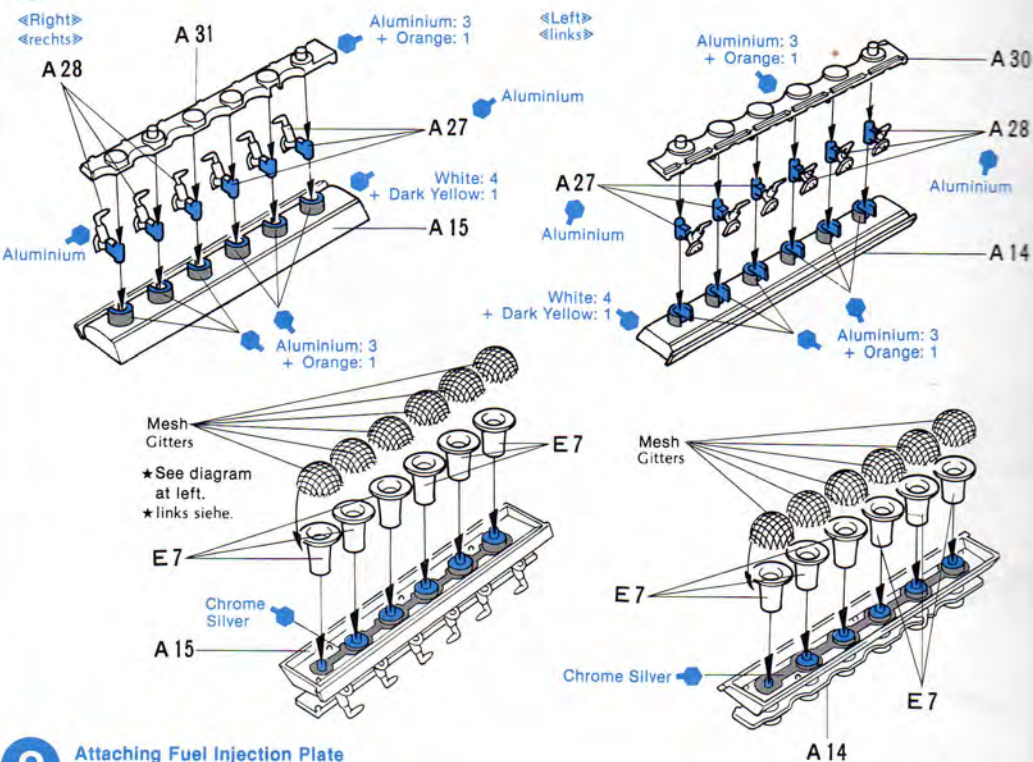

9 Attaching Fuel Injection Plate
Einspritz-Anlage Einbau

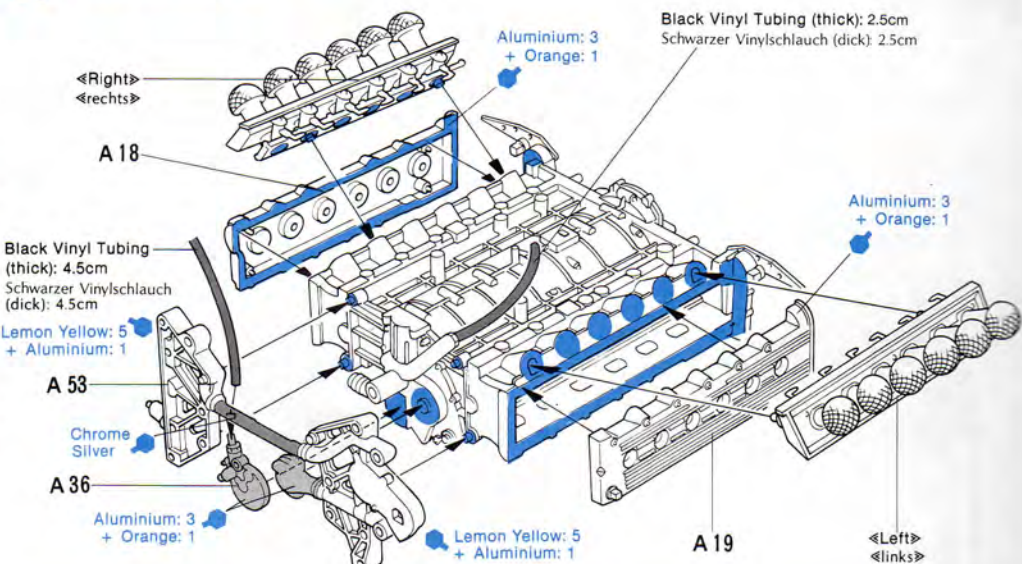

10 Ignition System
Einspritzanlage

Tie each bunch of wiring or tubing together as shown below.
Die Kabel wie gezeigt zusammenbinden.

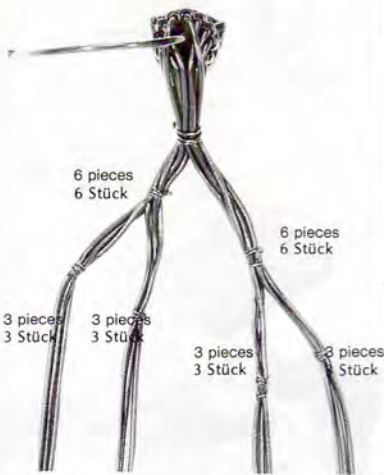

12 Attaching Ignition Parts
Einbau Zündanlage

Painting of Battery
Bemalung der Batterie



Wiring
Verkabelung der Zündanlage

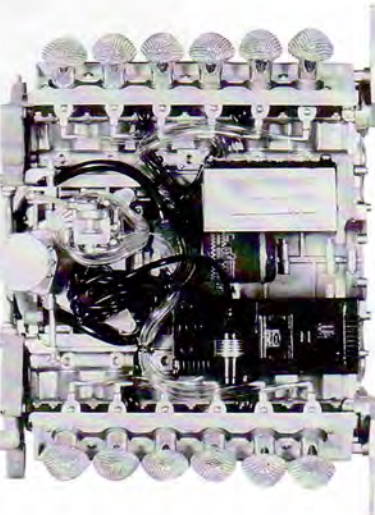

10 Ignition System
Einspritzanlage

Ignition System
Einspritzanlage

Black Vinyl Tubing (thin): 4cm
Schwarzer Vinylschlauch (dünn): 4 cm

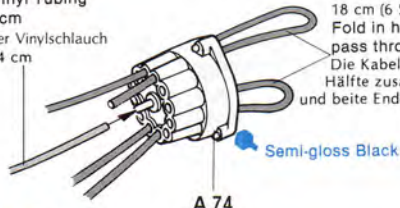

Vinyl Coated Wire: 18cm (6 pieces)
Vinylkabel: 18 cm (6 Stück)
Fold in half and pass through.
Die Kabel je zur Hälfte zusammenlegen und beide Enden einführen.

Fuel Pump
Kraftstoffpumpe

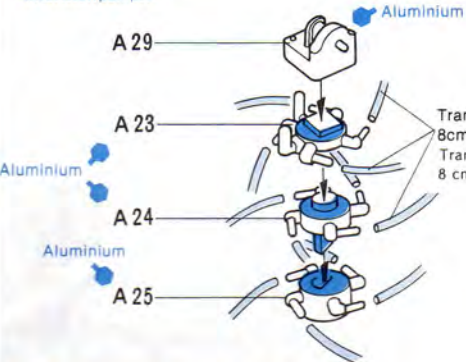

Ignition System
Einspritzanlage

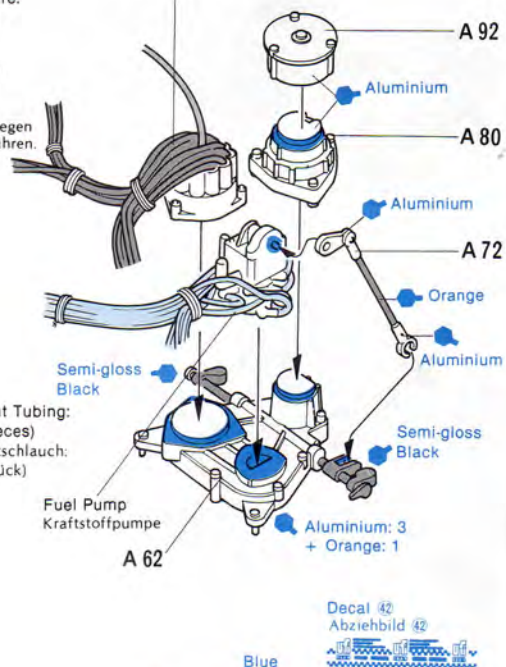

11 Attaching Ignition System
Einspritzanlage Einbau

Refer to photo at left.
links siehe

Ignition System
Einspritzanlage

Engine
Motor

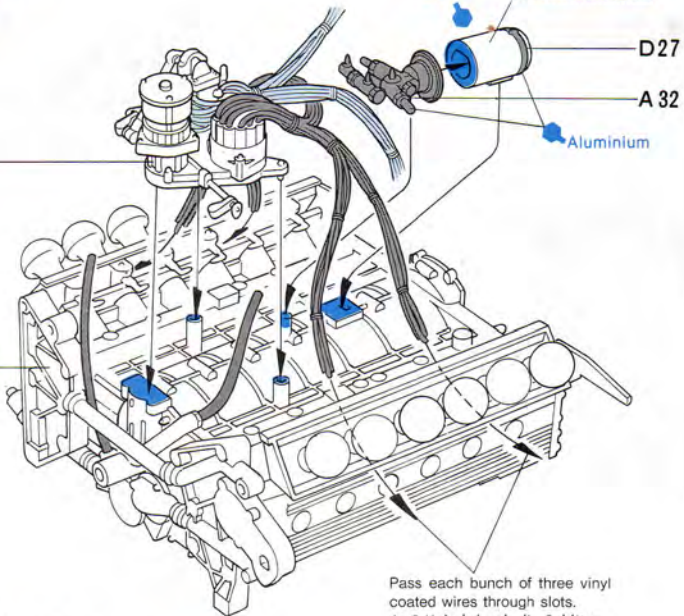

12 Attaching Ignition Parts
Einbau Zündanlage

Decal 45
Abziehbild 45

Black Vinyl Tubing (thin)
Schwarzer Vinylschlauch (dünn)

A 75

Decal 18
Abziehbild 18



Pass each bunch of three vinyl coated wires through slots.
Je 3 Kabel durch die Schlitzte stecken.

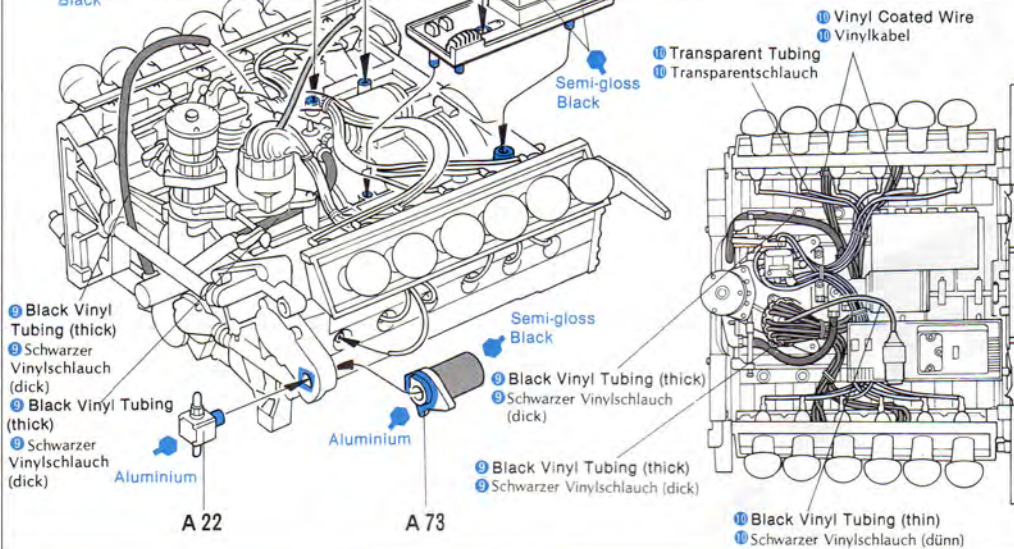

13 «Rear Brake Disc»
«Scheibenbremse hinten»



13 Rear Brake Disc
Scheibenbremse hinten

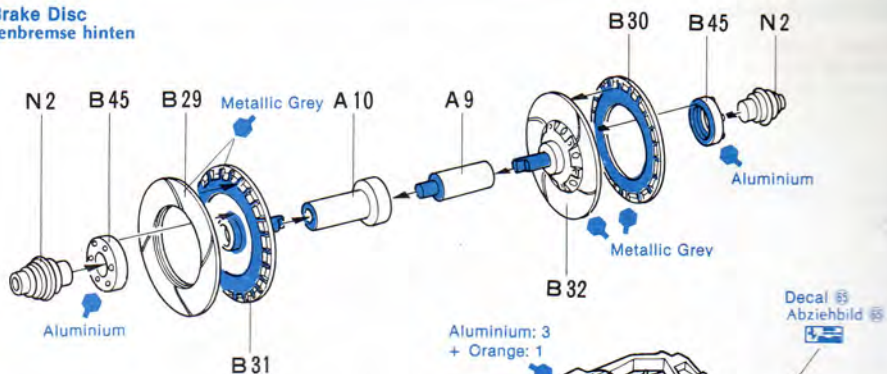

14 «Gear Box»
«Getriebe-Gehäuse»

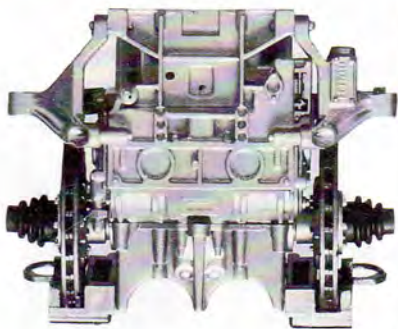

14 Gear Box
Getriebe-Gehäuse

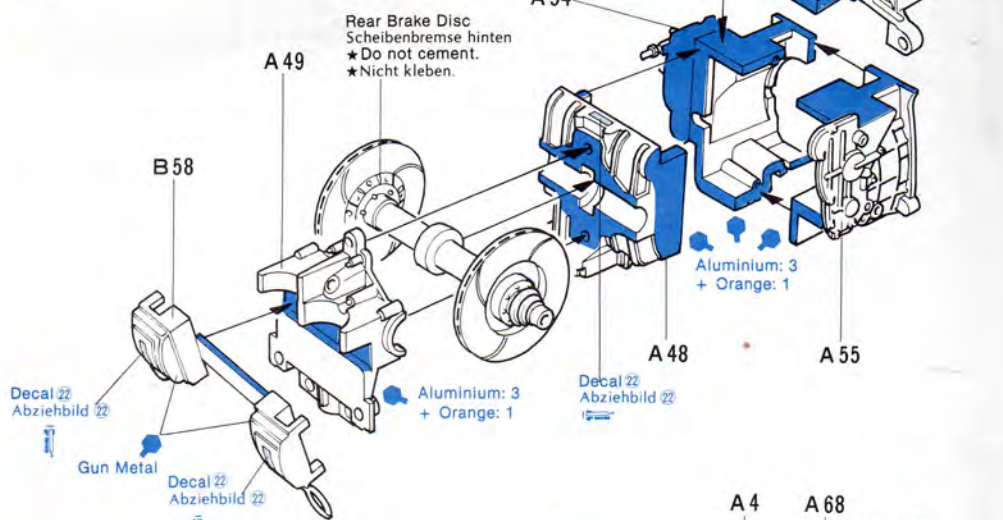

15 «Brake Air Duct»
«Bremsluftführung»

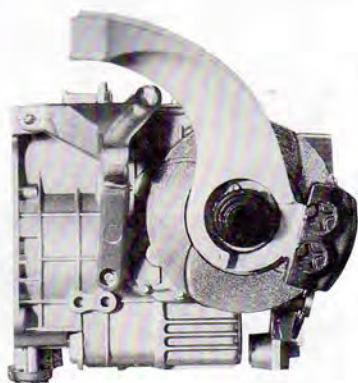

15 Brake Air Duct
Bremsluftführung

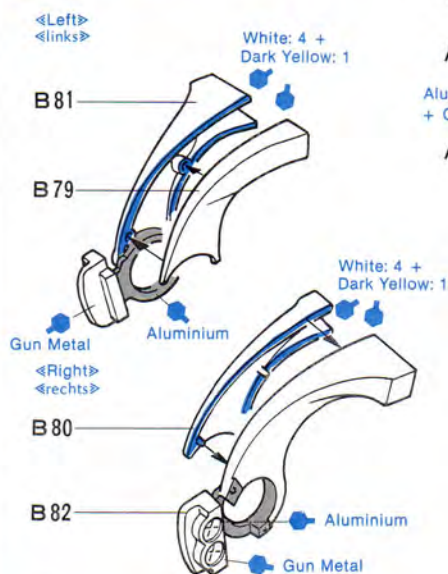

16 «Oil Cooler of Gear Box»
«Getriebe Öl Kühler»



16 Oil Cooler of Gear Box
Getriebe Öl Kühler

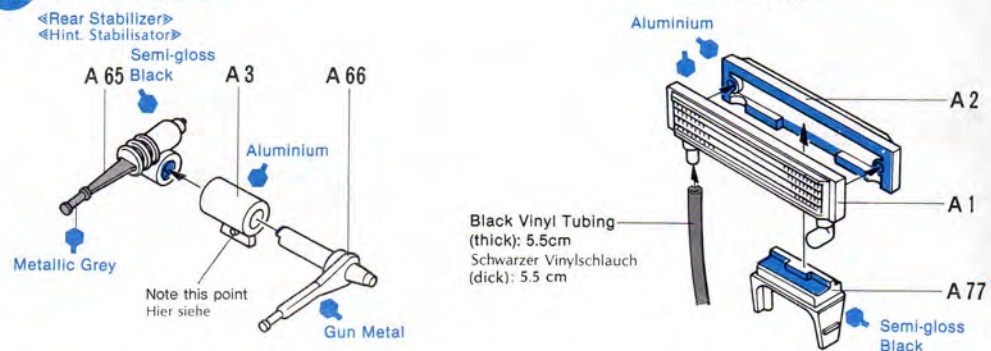

18 «Rear Upper Arm»
«Hint. Achsarm»



17 Damper
Stossdämpfer
«Rear Damper»
«Hint. Stossdämpfer»
★ Make 2 sets.
★ 2 Satz

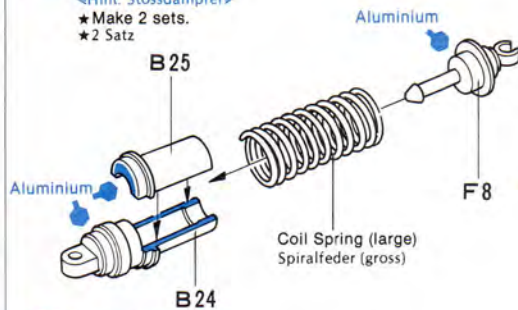

«Front Damper»
«Vord. Stossdämpfer»
★ Make 2 sets.
★ 2 Satz

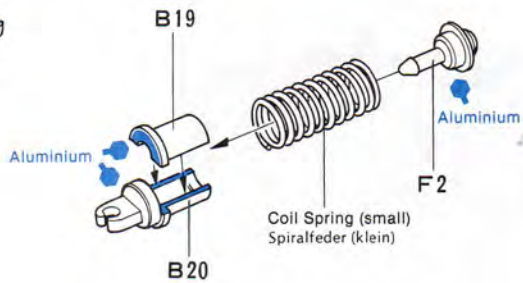

18 Rear Upper Arm
Hint. Achsarm

«Right»
«rechts»

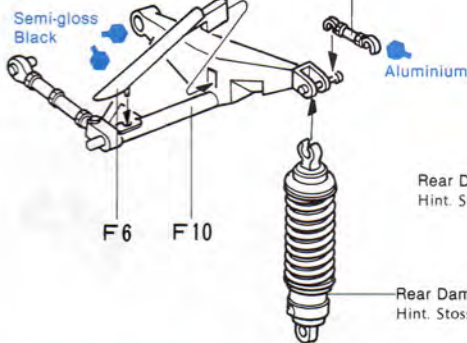

«Left»
«links»

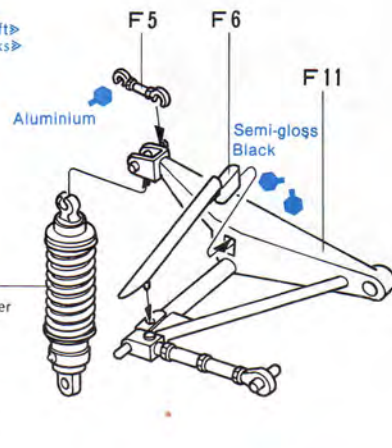

«Attaching Part F5»
«F5 Einbau»

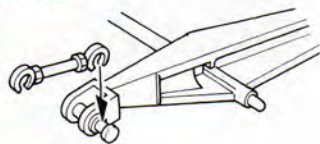

★ Force a link part to attach.
★ Vorsichtig eindrücken.

19 Attaching Rear Upper Arms
Einbau des Hint. Achsarm

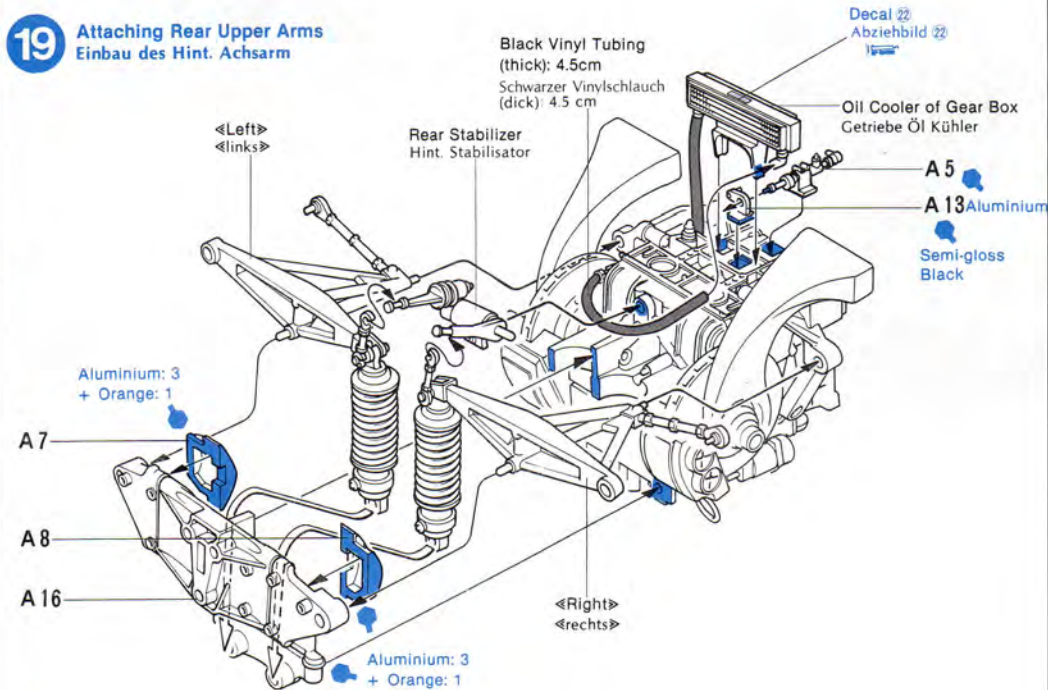

19 «Attaching Rear Upper Arms»
«Einbau des Hint. Achsarm»



20 «Rear Upright»
«Hint. Achs-Lager»



20 Rear Upright
Hint. Achs-Lager

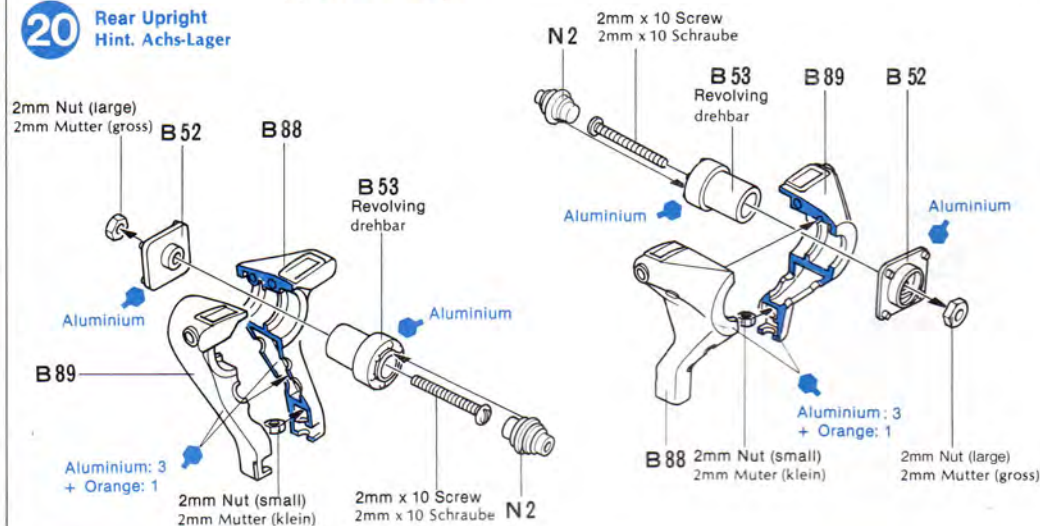

21 «Exhaust Pipe»
«Auspuff»

The exhaust pipes are similar to one another. Be careful to keep track of each piece when removing from sprue. Die Auspuffrohre sehen alle fast gleich aus. Auf die Nummern achten.

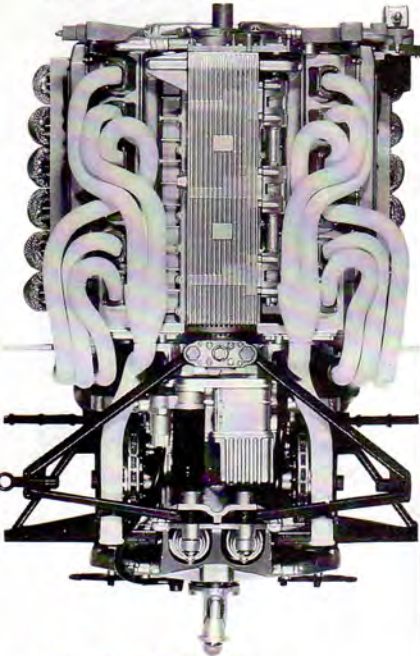

21 Exhaust Pipe
Auspuff

Exhaust Pipe/Auspuff
: Matt White: 4 +
Chrome Silver: 1

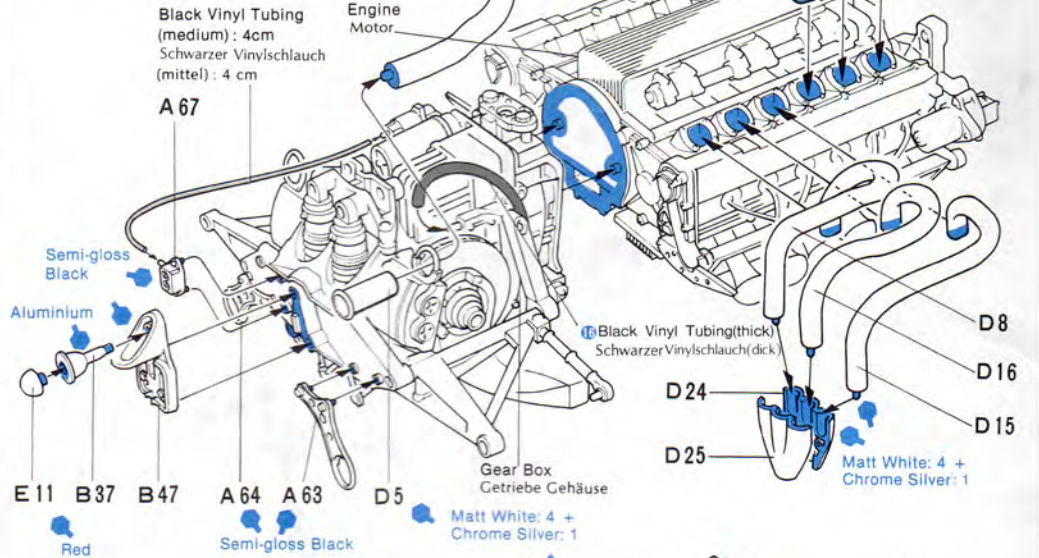

22 «Rear Bulkhead»
«Feuerwand»

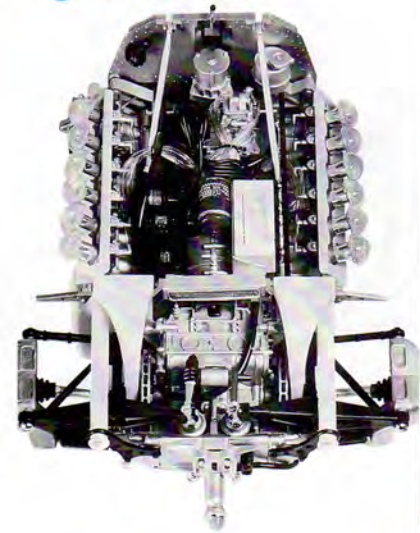

22 Rear Bulkhead
Feuerwand

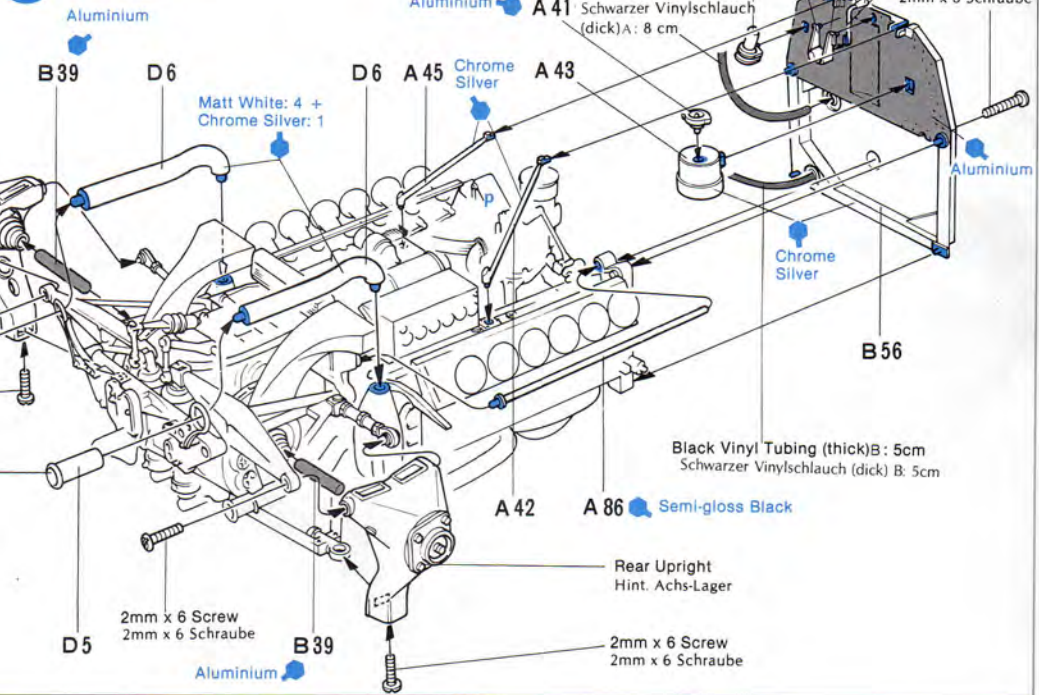

23 «Attaching Engine»
«Motor Einbau»

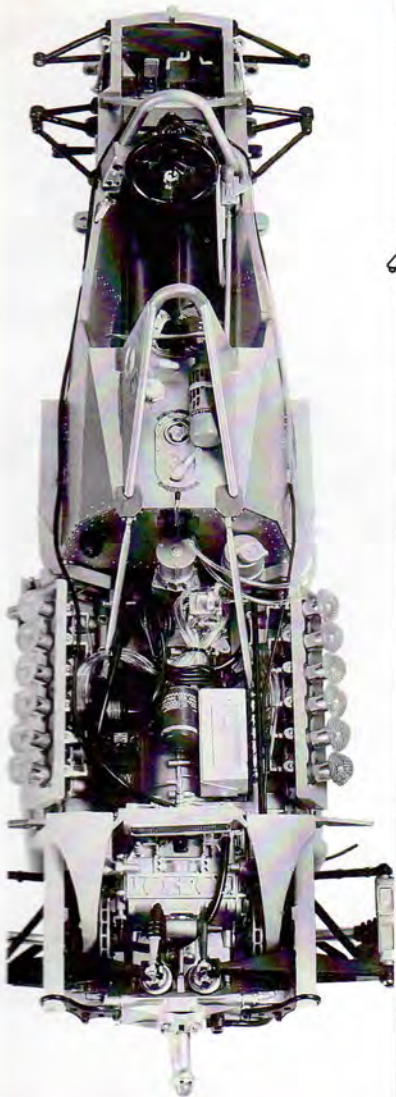

23 Attaching Engine
Motor Einbau

«Rear Roll Bar»
«Hint. Überroll Bügel»

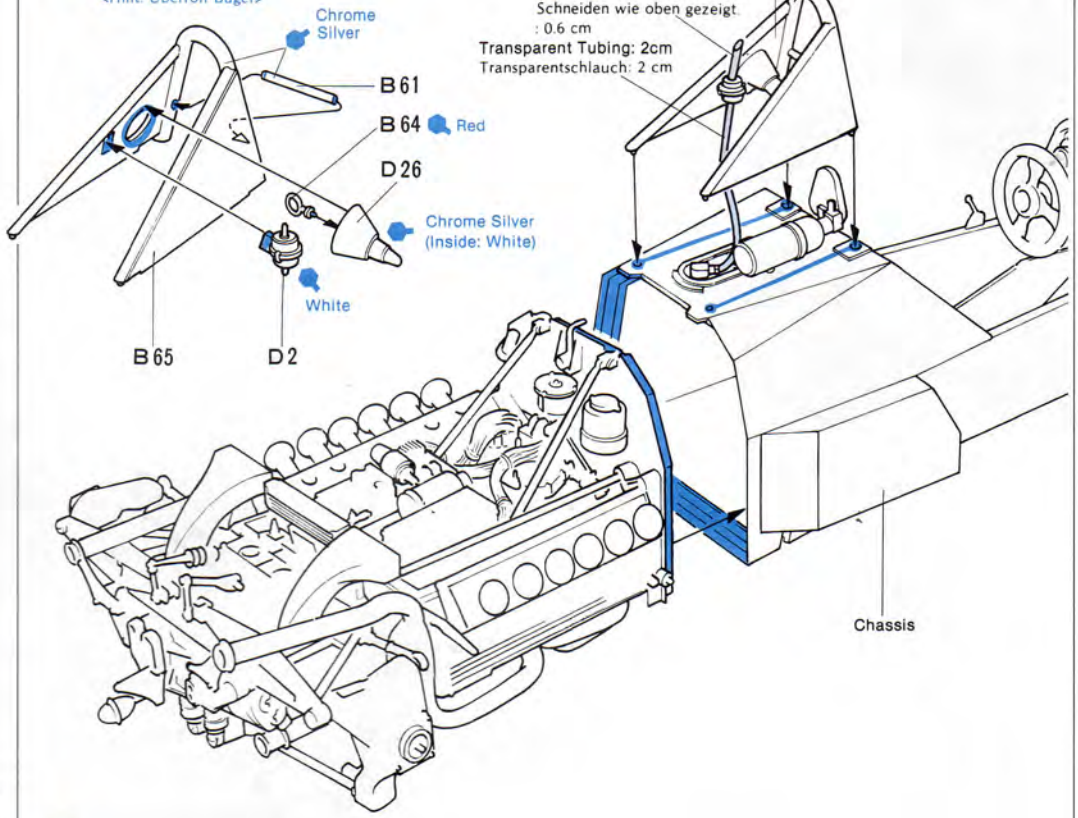

24 Front Upper Arm
Vord. Achsarm

«Right»
«rechts»

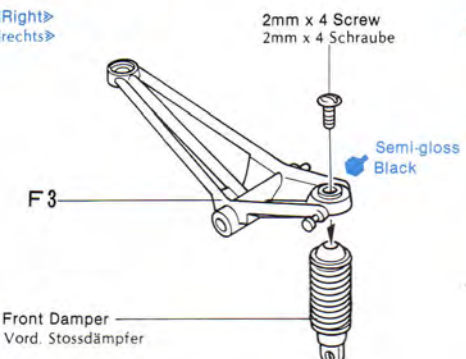

«Left»
«links»

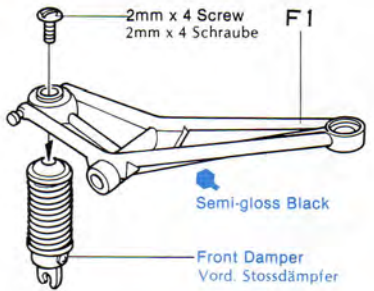

25 «Attaching Front Upper Arms»
«Vord. Achsarm Einbau»

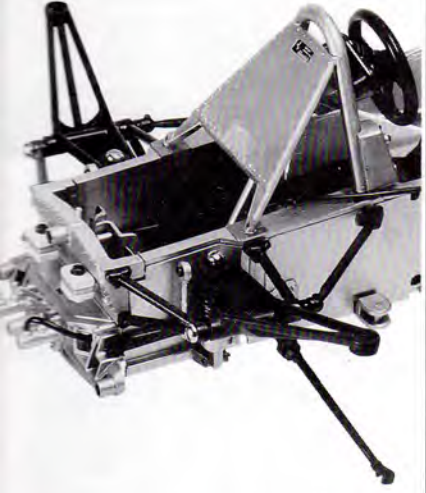

25 Attaching Front Upper Arms
Vord. Achsarm Einbau

«Right»
«rechts»

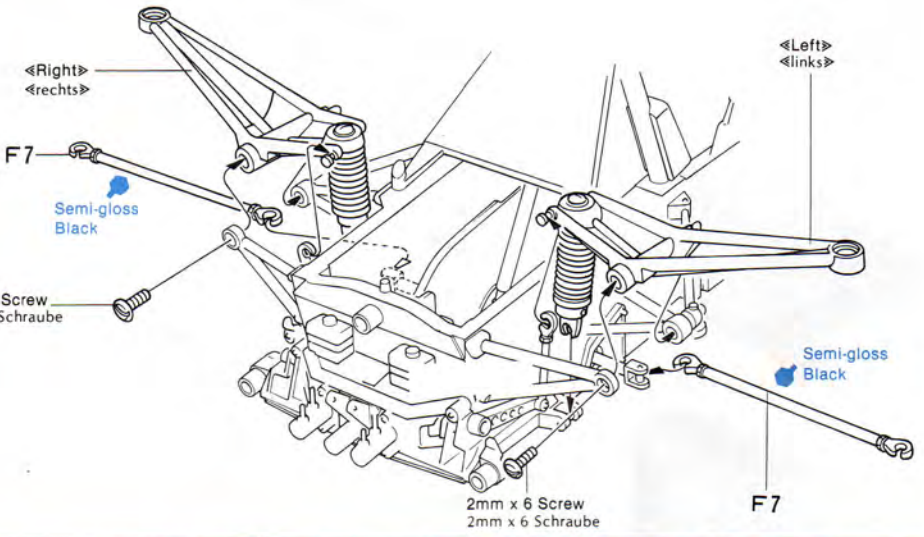

TAMIYA COLOR CATALOGUE
The latest in cars, boats, tanks and ships. Motorized, radio controlled and museum quality models are all shown in full color in Tamiya's latest catalogue. At your nearest hobby supply house.

Tamiya Acrylic Paints
Need precise colour matching? Try the new Tamiya acrylic paints. Engineered by modelers for modelers' use. The final cover for the finest models. Insist on Tamiya for perfect results.



26 «Front Upright»
«Vord. Achs-Lager»



26 Front Upright
Vord. Achs-Lager

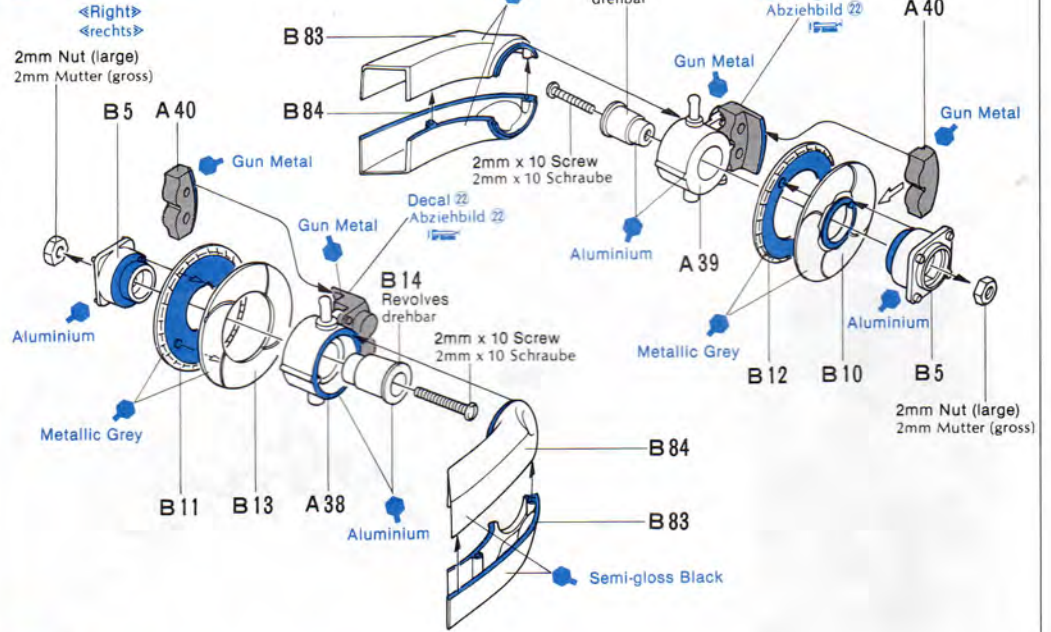

27 «Assembly of Front Uprights»
«Einbau der Vord. Achs-Lager»

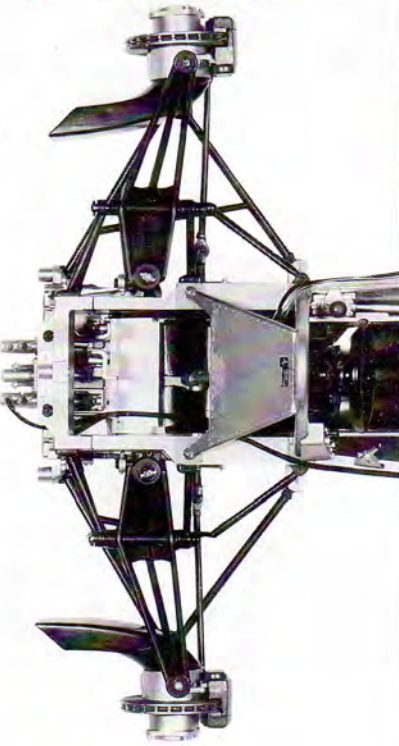

27 Assembly of Front Uprights
Einbau der Vord. Achs-Lager

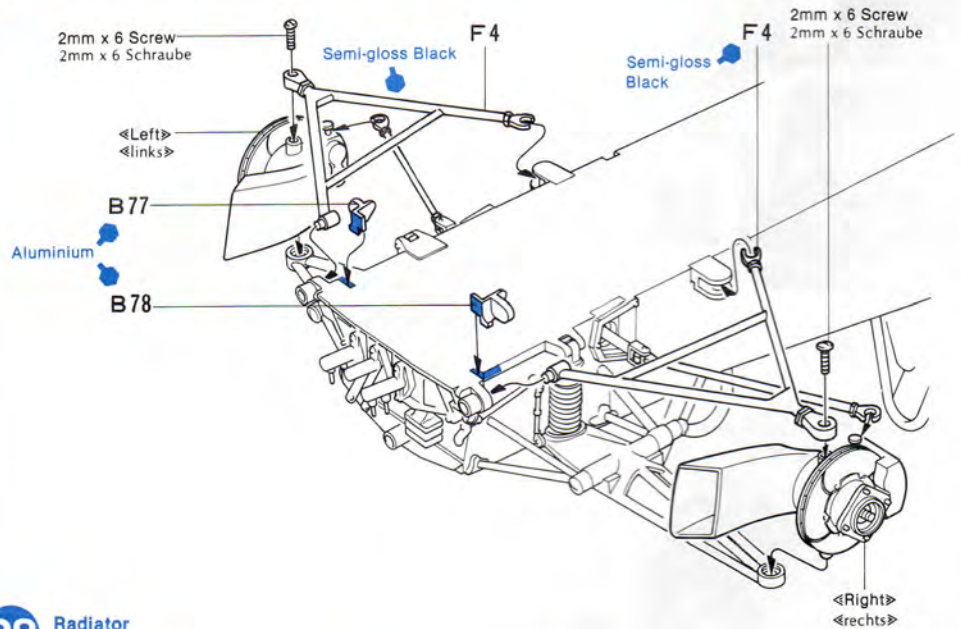

28 «Radiator»
«Kühler»



28 Radiator
Kühler

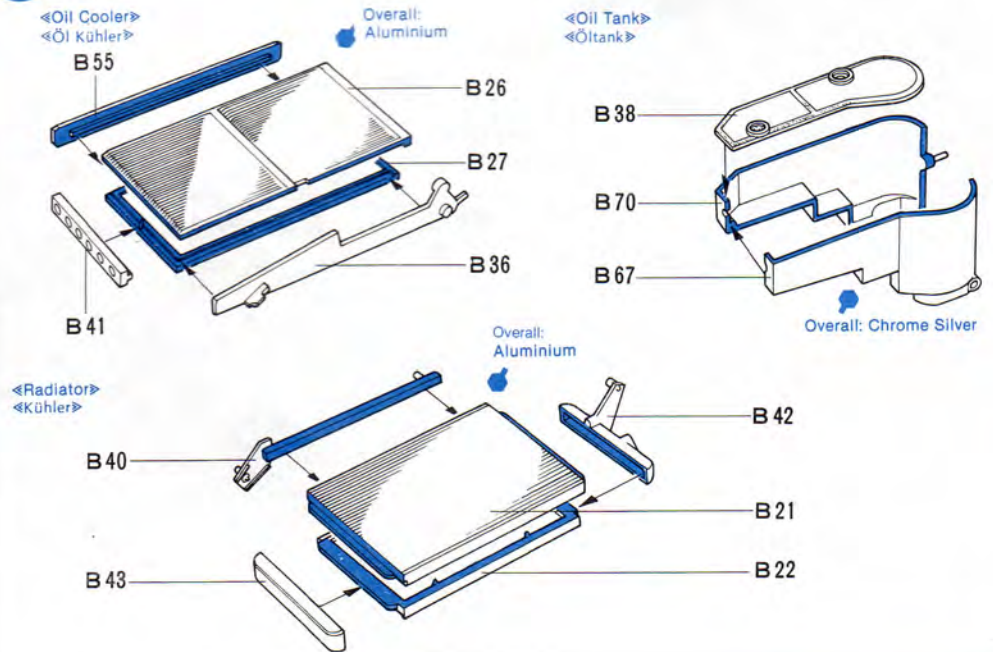

29 <<Attachment of Oil Cooler>>
<<Öl-Kühler Einbau>>
<<B86 Placement>>
<<B86 Einbau>>

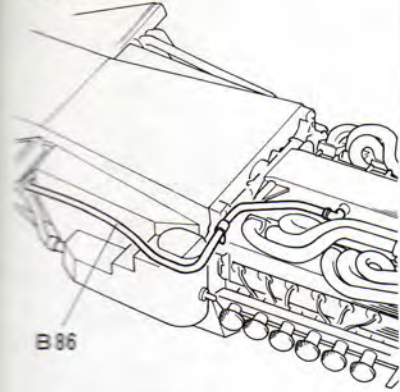

B 86

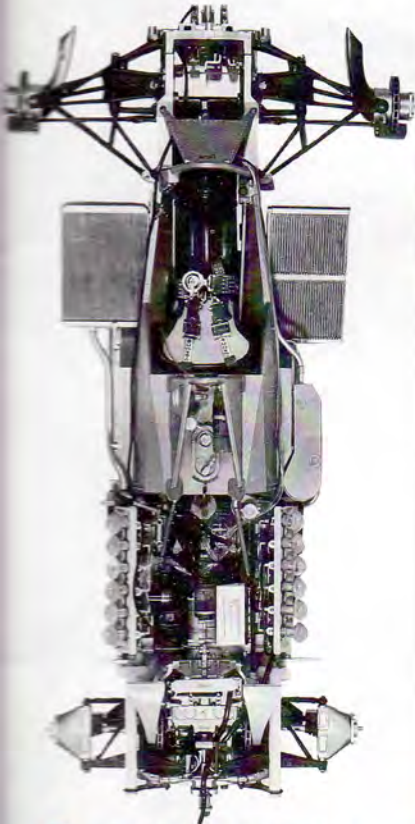

29 Attachment of Oil Cooler
Öl-Kühler Einbau

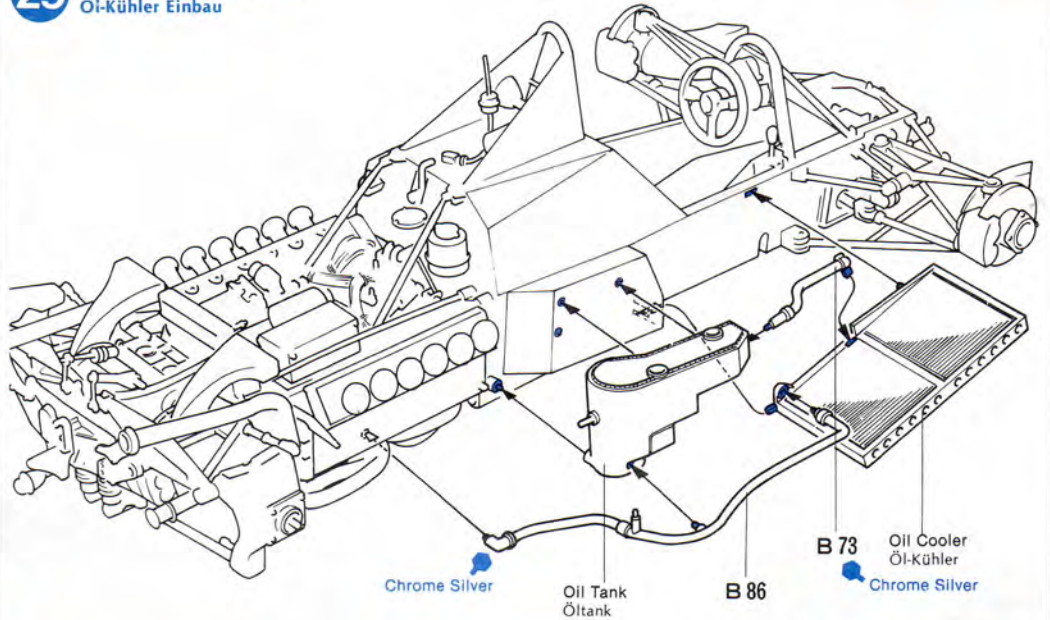

Chrome Silver

Oil Tank
Öltank

B 86

B 73 Oil Cooler
Öl-Kühler
Chrome Silver

30 Attaching Radiator
Kühler Einbau

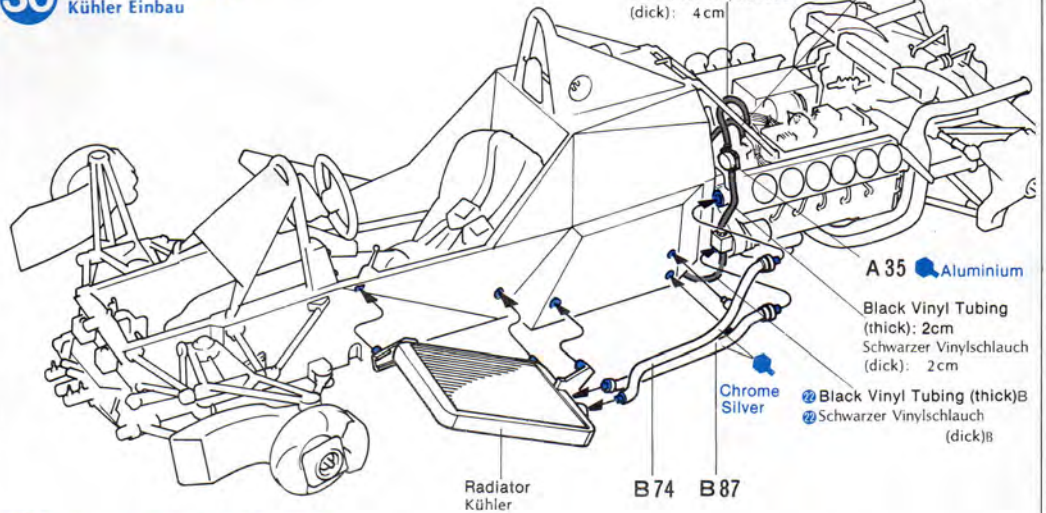

Black Vinyl Tubing (thick): 4cm
Schwarzer Vinylschlauch (dick): 4cm

② Black Vinyl Tubing (thick) A
② Schwarzer Vinylschlauch (dick) A

A 35 Aluminium

Black Vinyl Tubing (thick): 2cm
Schwarzer Vinylschlauch (dick): 2cm

② Black Vinyl Tubing (thick) B
② Schwarzer Vinylschlauch (dick) B

Radiator
Kühler

B 74 B 87

Chrome Silver

31 Installation of Vinyl Tubings
Vinylschlauch Einbau

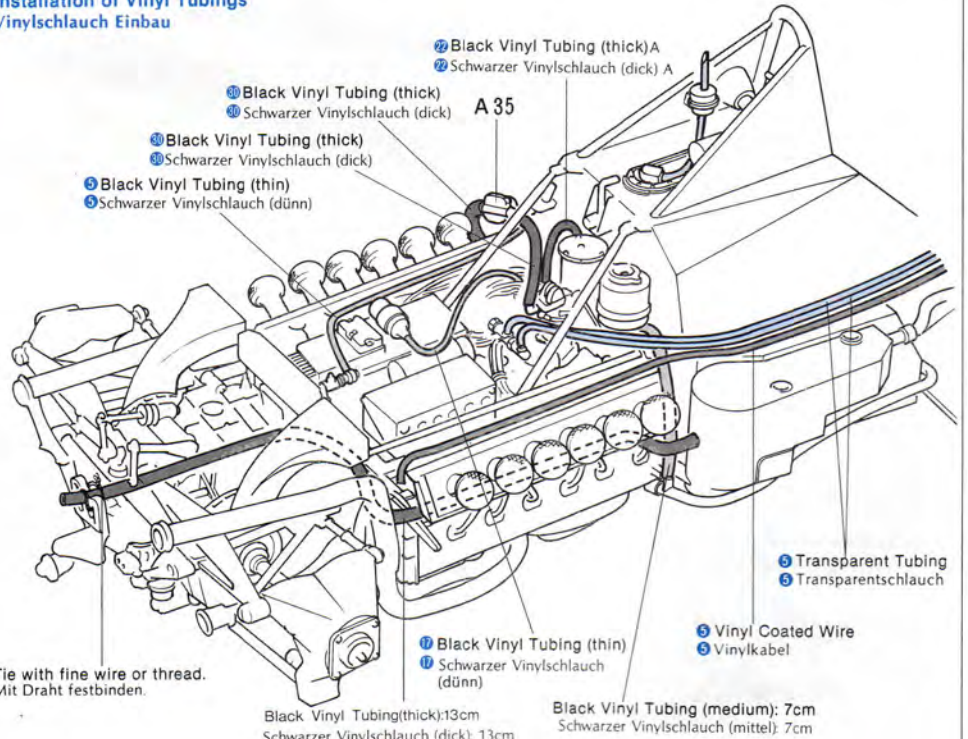

② Black Vinyl Tubing (thick) A
② Schwarzer Vinylschlauch (dick) A

⑩ Black Vinyl Tubing (thick)
⑩ Schwarzer Vinylschlauch (dick)

⑩ Black Vinyl Tubing (thick)
⑩ Schwarzer Vinylschlauch (dick)

⑤ Black Vinyl Tubing (thin)
⑤ Schwarzer Vinylschlauch (dünn)

A 35

⑤ Transparent Tubing
⑤ Transparentschlauch

⑤ Vinyl Coated Wire
⑤ Vinylkabel

Tie with fine wire or thread.
Mit Draht festbinden.

⑦ Black Vinyl Tubing (thin)
⑦ Schwarzer Vinylschlauch (dünn)

Black Vinyl Tubing (thick): 13cm
Schwarzer Vinylschlauch (dick): 13cm

Black Vinyl Tubing (medium): 7cm
Schwarzer Vinylschlauch (mittel): 7cm

Blue

★ Hangs down.
★ Hängt nach unten.

31 <<Installation of Vinyl Tubings>>
<<Vinylschlauch Einbau>>

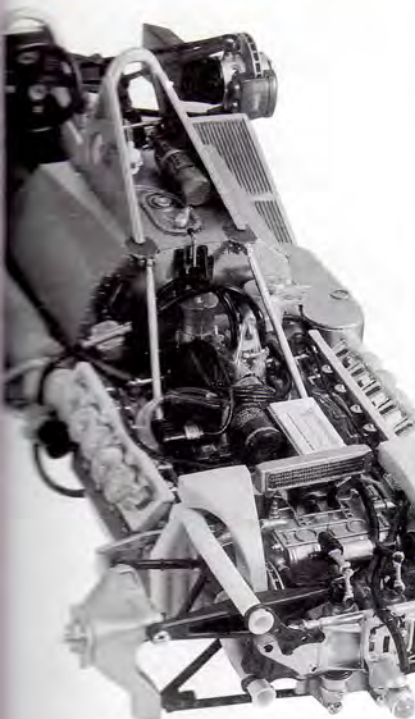

32 <<Side Pontoons>>
<<Seiten Pontoons>>

Cut off.
Abschneiden.

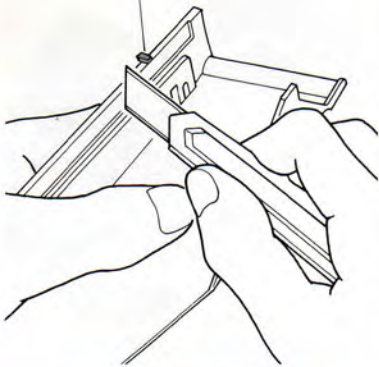

33 <<Assembly of Side Skirts>>
<<Seitenverkleidung>>

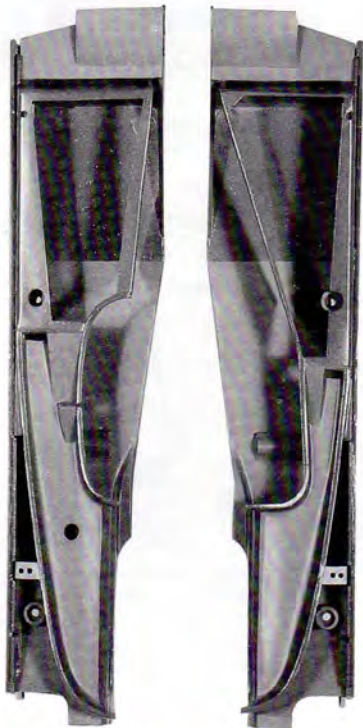

<<How to Assemble Side Skirts>>
<<So einbauen>>

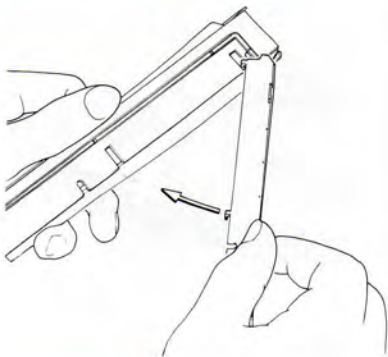

<<Attaching C5>>
<<C5 Einbau>>

Attach C5 after cementing B3 or B7.
Erst B3 oder B7 einkleben, dann C5.

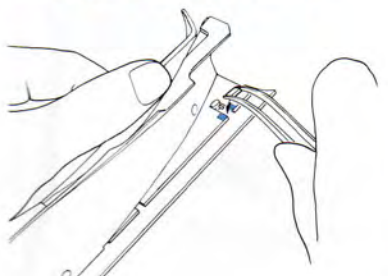

32 Side Pontoons
Seiten Pontoons

<<Left>>
<<links>>

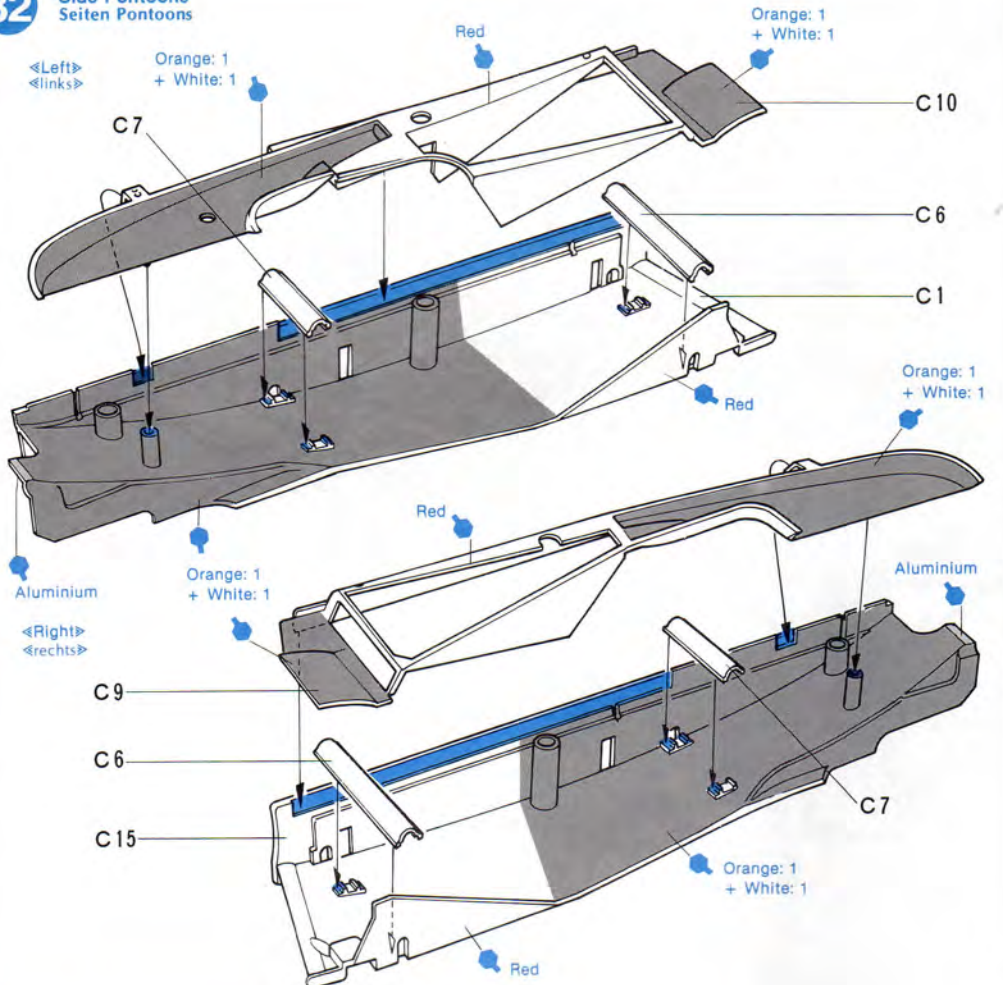

33 Assembly of Side Skirts
Seitenverkleidung

<<Right>>
<<rechts>>

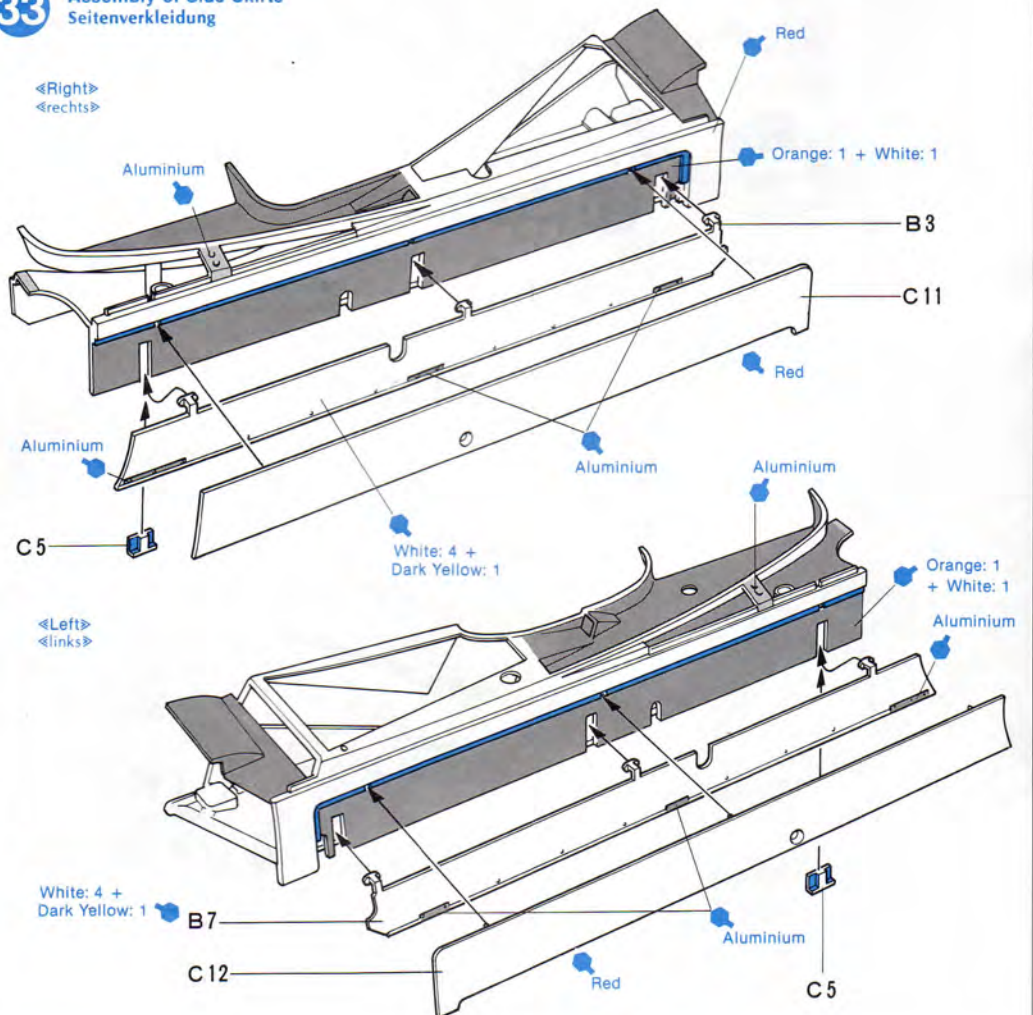

34 «Attaching Side Pontoons»
«Einbau der Seiten Pontoons»

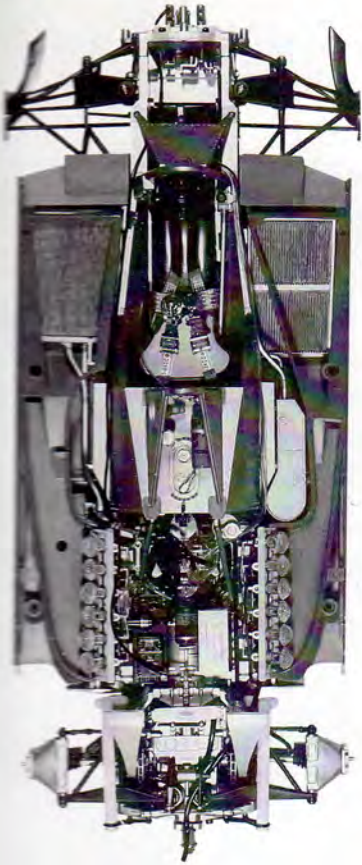

34 Attaching Side Pontoons
Einbau der Seiten Pontoons

2mm x 4 Countersunk
Head Screw
2mm x 4 Senkkopfschraube

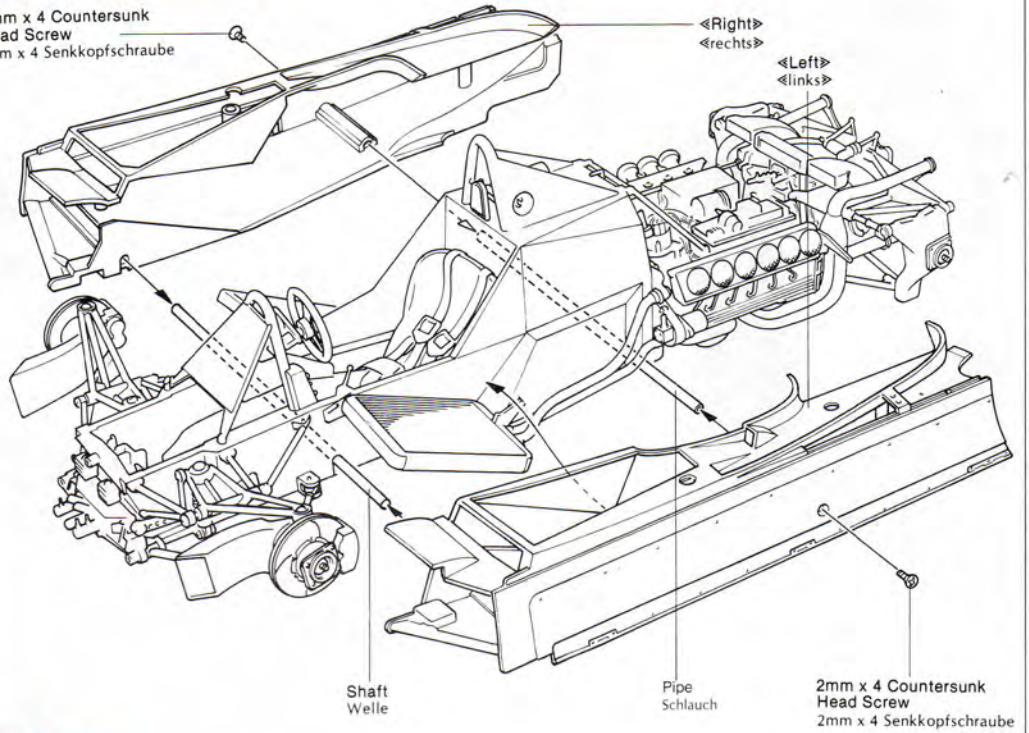

35 Wheels
Räder

«Front» ★ Make 2 sets.
«vorne» ★ 2 Satz

★ Take care of each arrow on tyres
when assembling wheels.
★ Auf die Pfeilrichtung an den
Reifen achten

«Rear» ★ Make 2 sets.
«hinten» ★ 2 Satz

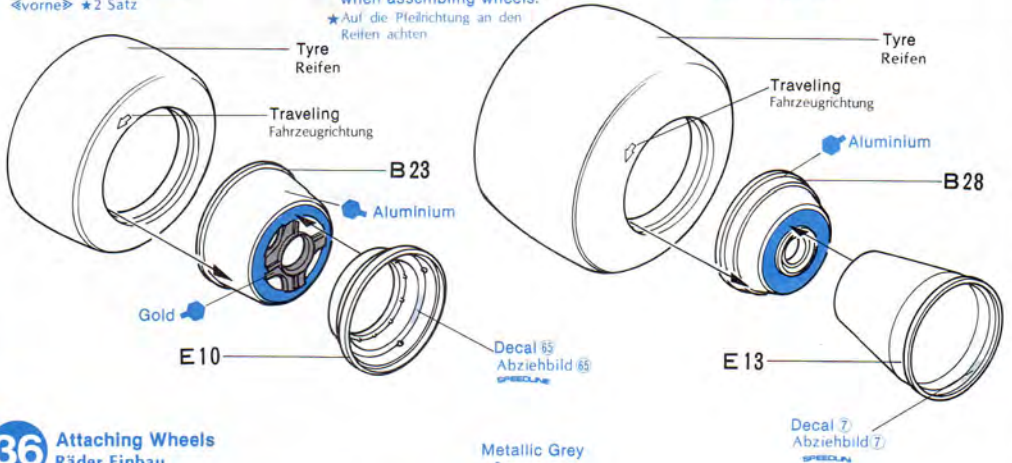

36 Attaching Wheels
Räder Einbau

B 54
Metallic Grey

Front Wheel
Vorderrad

«Making a wrench»
«Mutternschlüsselbau»

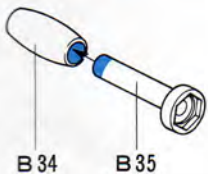

★ Use G1 under the chassis of your completed model for static display.
★ C1 unter den Chassis hält das Modell gerade.

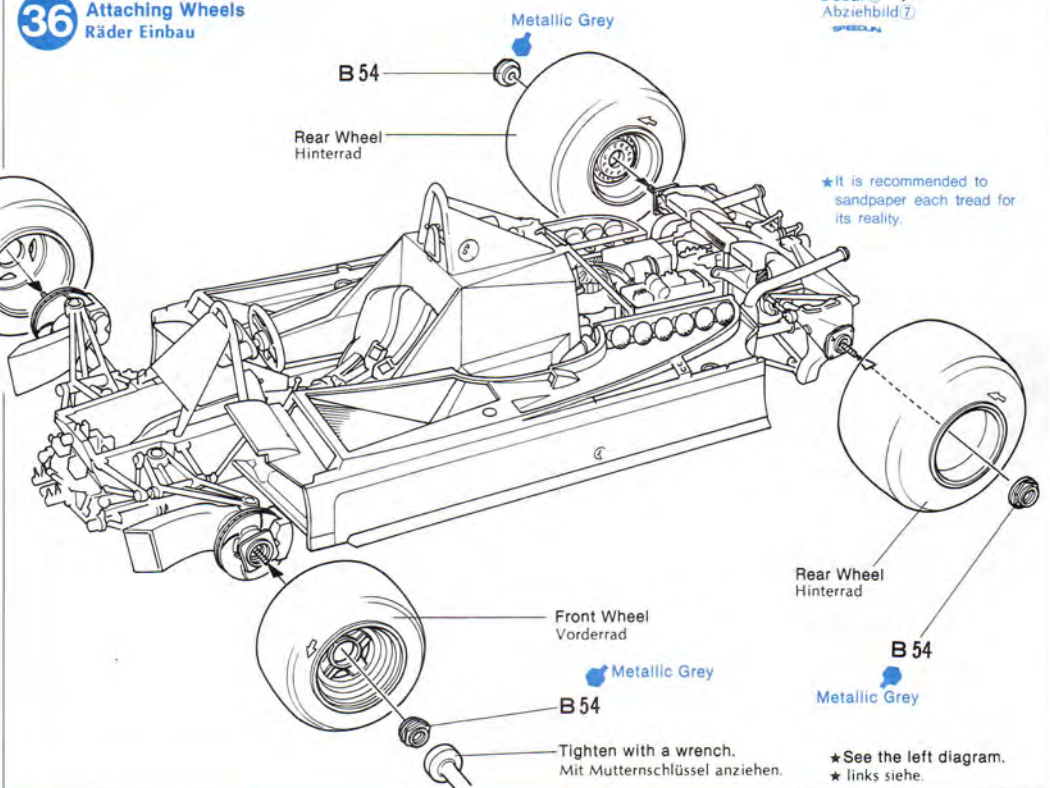

38

«Cockpit Cowling: outside»
«Cockpit Verkleidung: aussen»

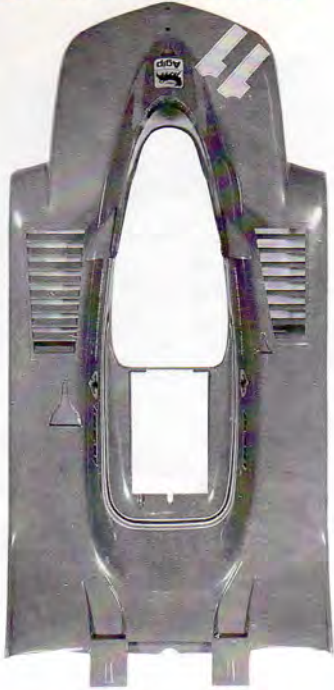

«Driver's Decal»
«Abziehbilder für Fahrer und Helm im Kit»
Decals for a driver and his helmet are contained in this kit, but the figure and helmet are not.
Fahrer und Helm im Kit nicht enthalten.

J. Scheckter

«Helmet»
«Helm»

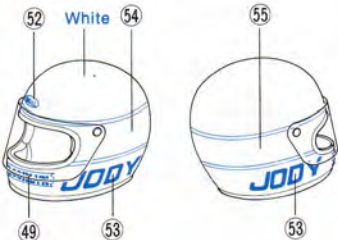

«Driver»
«Fahrer»



G. Villeneuve

«Helmet»
«Helm»

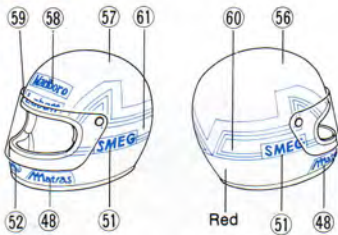

«Driver»
«Fahrer»

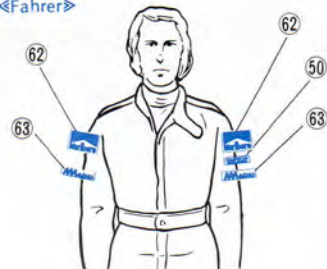

37

Cockpit Cowling: inside
Cockpit Verkleidung: innen

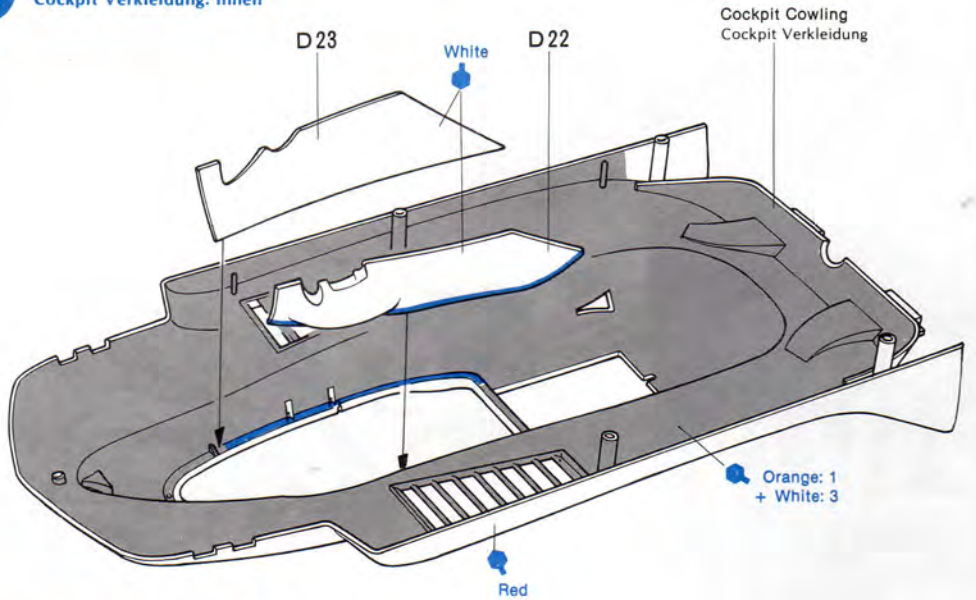

38

Cockpit Cowling: outside
Cockpit Verkleidung: aussen

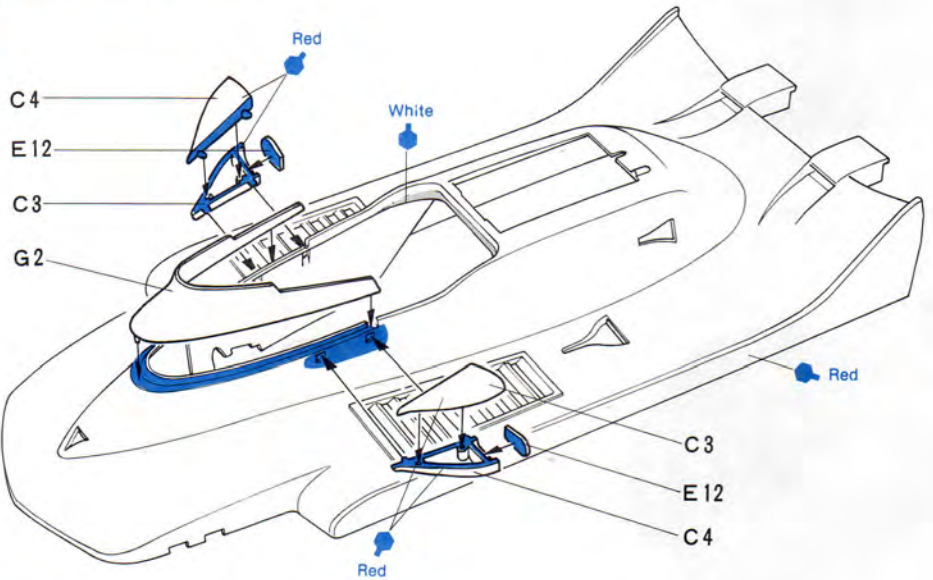

39

Rear Wing
Heckspoiler

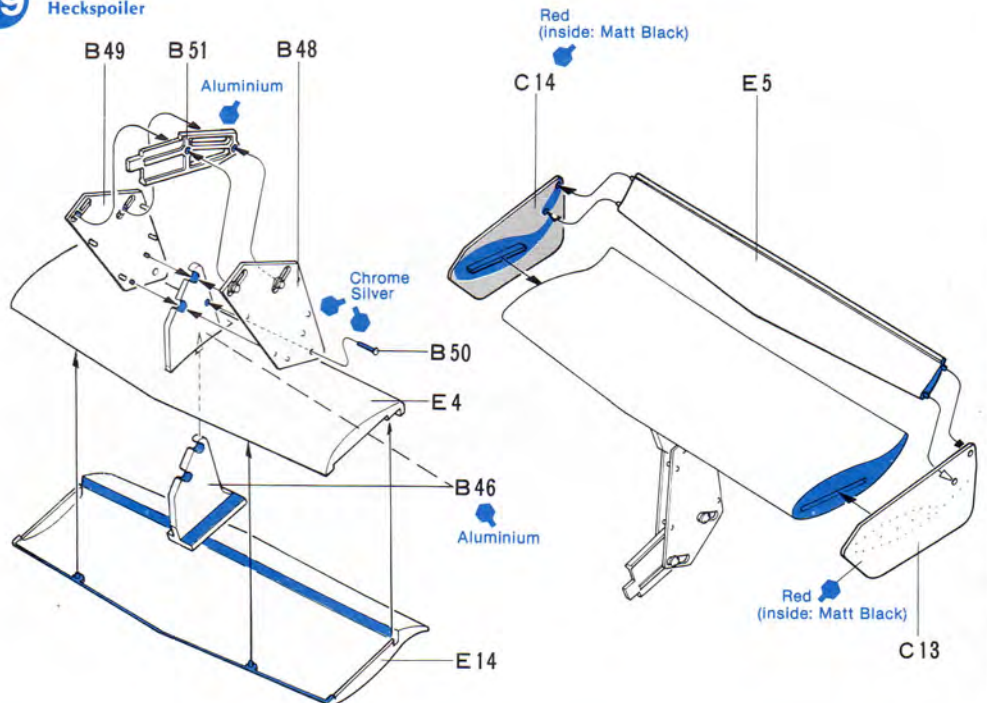

41 <Completion>
<Endmontage>

40 Nose Cowling
Front Verkleidung Spoiler

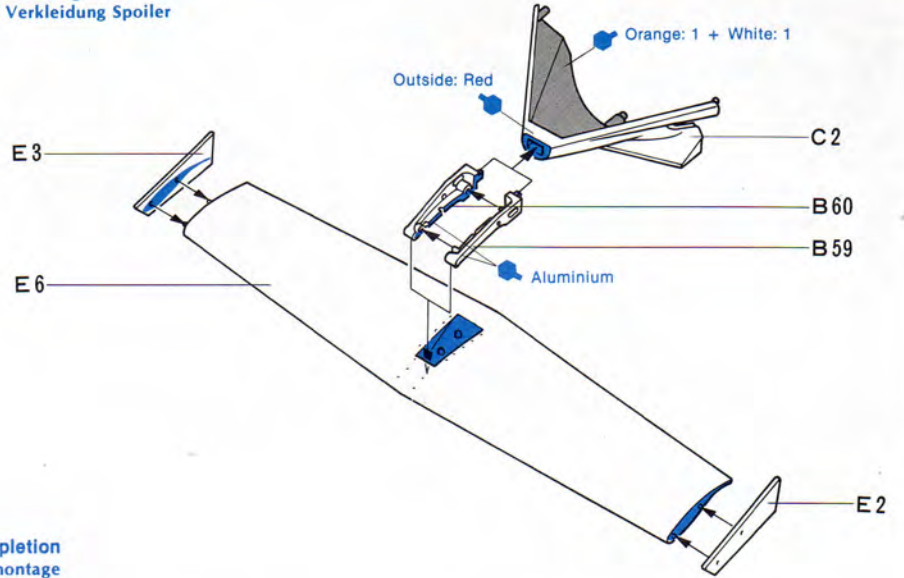

41 Completion
Endmontage

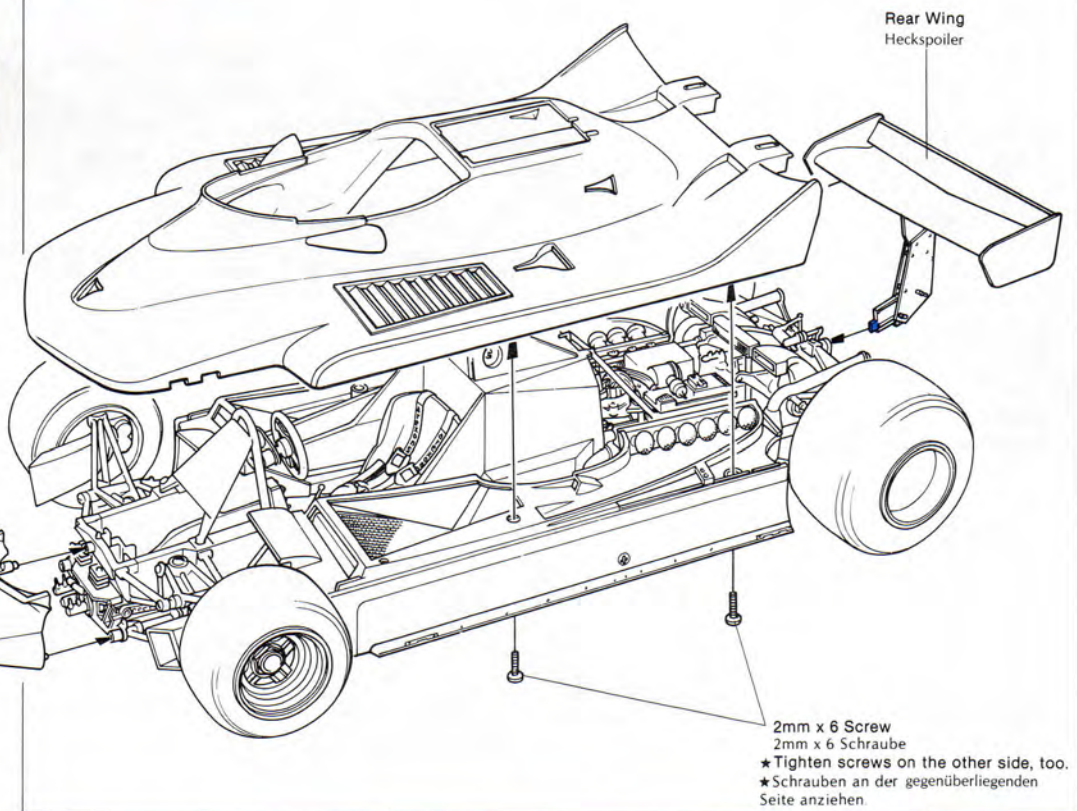

Nose Cowling
Front Verkleidung Spoiler

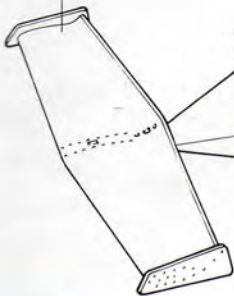

<Tightening screw>
<Schrauben anziehen>

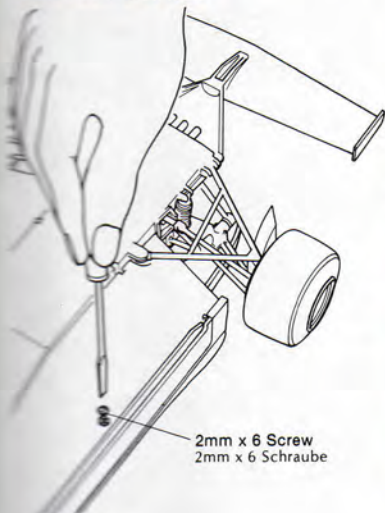

2mm x 6 Screw
2mm x 6 Schraube



PAINTING & APPLYING DECALS

«PAINTING OF FERRARI 312T4»

The Ferrari 312T4 made its debut at the 1979 South African Grand Prix and that year won the Manufacturers Championship and, with Jody Scheckter at the wheel, also the F1 Drivers Championship. The basic colour of the car is a brilliant red, the Italian national colour. Thin white stripes are painted on the body side and along the front edge of the body cowling. Stripes of green, white and red are applied to the upper body cowling behind the cockpit. The Ferrari symbols of the prancing horse are placed next to the lettering of the car driver's name on either side of the car. No. 11 car was driven by Jody Scheckter, No. 12 car by Gilles Villeneuve. These numbers are placed on the front and on either side of each car. For detailed painting refer to the instructions. Do not spray any of the decals in this kit with clear lacquer.

«Bemalung des Ferrari 312T4»

Der Ferrari 312T4 wurde erstmals 1979 im Grand Prix von South Africa vorgestellt und gewann die Hersteller-Meisterschaft und auch die Formel 1 Fahrer-Meisterschaft mit Jody Scheckter am Steuer.

Die Grundfarbe ist brilliant-rot, die Nationalfarbe Italiens. Dünne, weisse Streifen sind auf den Karosserieteilen und auch an den Frontkanten der Verkleidung gezogen. Streifen in grün, weiss und rot sind hinter dem Cockpit. Das Markenzeichen von Ferrari, das sich aufbäumende Pferd, ist auf beiden Seiten in der Nähe des Fahrernamens vorne und an den Seiten ist die Nummer 11 für Jody Scheckter oder No. 12 für Gilles Villeneuve angebracht. Detailbemalung siehe Anleitung. Abziehbilder nicht mit Klarlack besprühen!

«Before painting»

Remove all dust, dirt and adhesive smears before attempting any painting. Remember painting does not generally hide bad workmanship. As previously mentioned, remove excessive glue or joins with a file, sharp knife or very fine emery cloth. Most parts are best painted after assembly, but some inaccessible parts may be painted before removing from the sprue.

«Vor dem Malen»

Soll man Staub und Leimreste entfernen. Auch eine gute Bemalung verdeckt nicht schlechte Bauarbeit. Unebenheiten mit Feile oder Klinge entfernen. Viele Teile lassen sich erst nach dem Zusammenbau bemalen, jedoch die kleinen Teile bemalt man am besten am Spritzling.

«Spray Painting Hints»

Firstly always spray indoors in windless and dust-free conditions. Spread newspaper under your work. Mix the paint well by shaking the can for three minutes and then test spray against some cardboard from about 20 cm, checking that the paint is properly mixed. When spraying the body, hold the

can about 20 cm from the plastic, moving the can quickly always in the same direction and ensure every application. A good tip is to imagine you are spraying a large surface, i.e. the surrounding newspaper, you will then probably achieve a more even finish.

«Bemalung mit Sprayfarben»

Nur in zug- und staubfreien Räumen spritzen. Teile auf ausgebreitete Zeitung stellen. Spraydose gut durchschütteln (3 Min) und durch Spritzen auf Karton prüfen, ob Farben gut gemischt ist. (20 cm Abstand). Das Modell in gleicher Richtung grossflächig besprühen. Keine Sprayfarben auf Nitrobasis sondern nur Sprayfarben für Polystyrol Plastik verwenden.

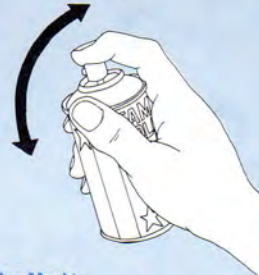

«Dealer Mark»

France G.P.



Long Beach G.P.



British G.P.



Belgian G.P.



«Decal Application»

1 Remove all dust, dirt and adhe-

sive smears with a wet cloth before applying any decals.

2 The decal to be applied should be removed beforehand from the decal sheet. Cut off translucent films along coloured parts.

3 Dip the decal in tepid water for about 10 seconds and then remove it onto a clean cloth. Be careful of over immersion to avoid loss of decal's adhesive.

4 Hold the backing sheet edge and slide the decal onto the model.

5 Wet the decal with a little water on your finger so that it can be moved more easily into position.

6 Press the decal down gently with a clean soft cloth to remove air bubbles and until all excess water has been fully absorbed. When a decal has to be applied to a surface which is uneven or curved, press the decal down with a hot towel so that the decal will fit the contours perfectly. Cut off the excess transparent portion around each decal. The decal must then not be touched until dry.

«Abziehbilder-Decals»

1 Staub, Schmutz und Klebstoffreste mit nassem Tuch entfernen.

2 Decals erst ausschneiden entlang den Linien.

3 Decals in Wasser legen, dann nach 10 Sekunden auf z.B. Handtuch legen und etwas abtrocknen lassen.

4 Decal an der Unterlage halten und Bild auf das Modell schieben.

5 Mit etwas Wasser auf dem Finger lässt sich das Decal noch etwas verschieben.

6 Decal mit etwas Stoff gut andrücken, um die Luftblasen zu entfernen und das Wasser abzutrocknen. An unebenen Stellen kann man mit heissen Tuch das Decal besser andrücken. Transparente Überreste am Decal abschneiden. Decal nicht mehr berühren, bis getrocknet ist.

«Painting of Ferrari 312T4»



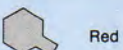



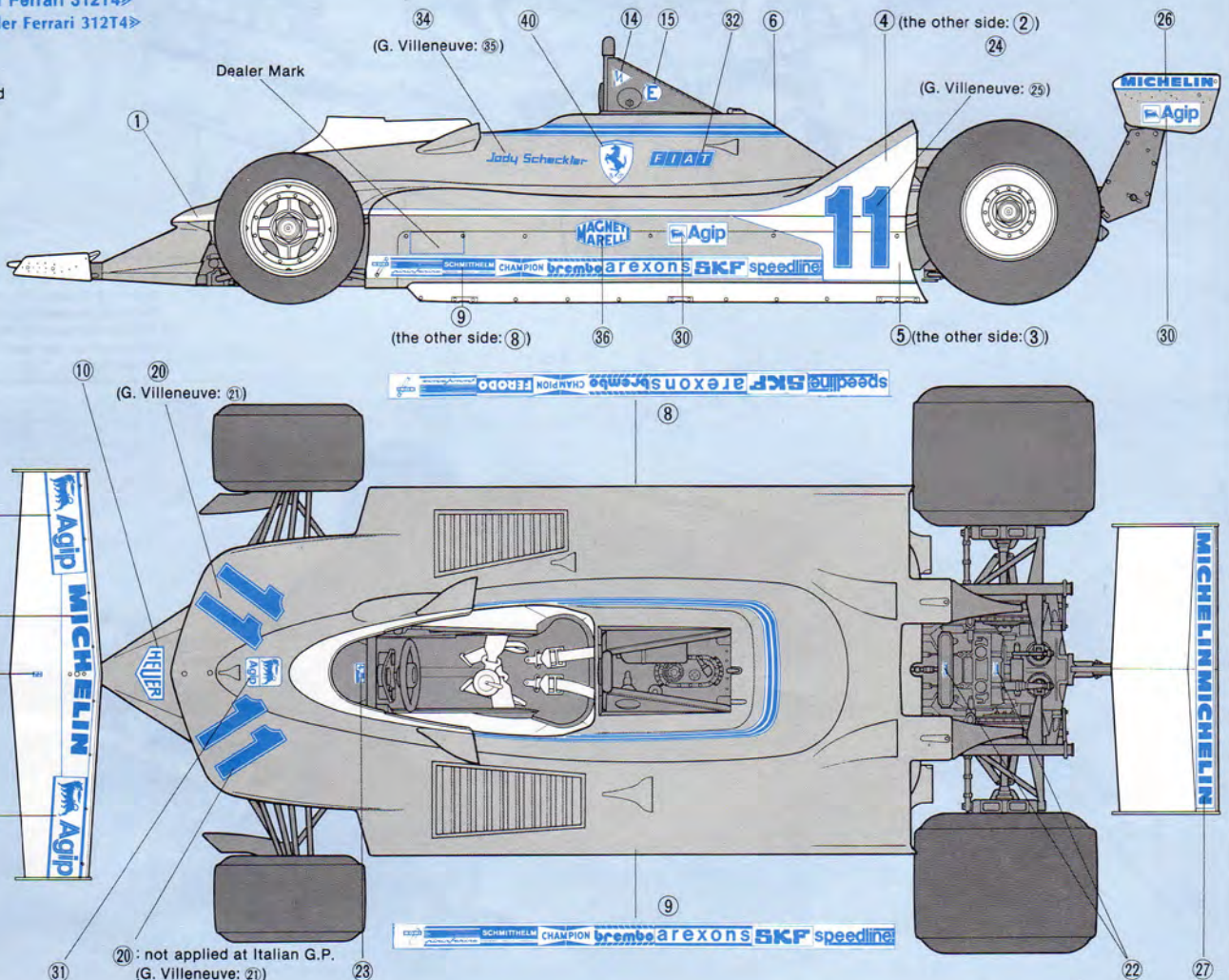

«Bemalung der Ferrari 312T4»



Red





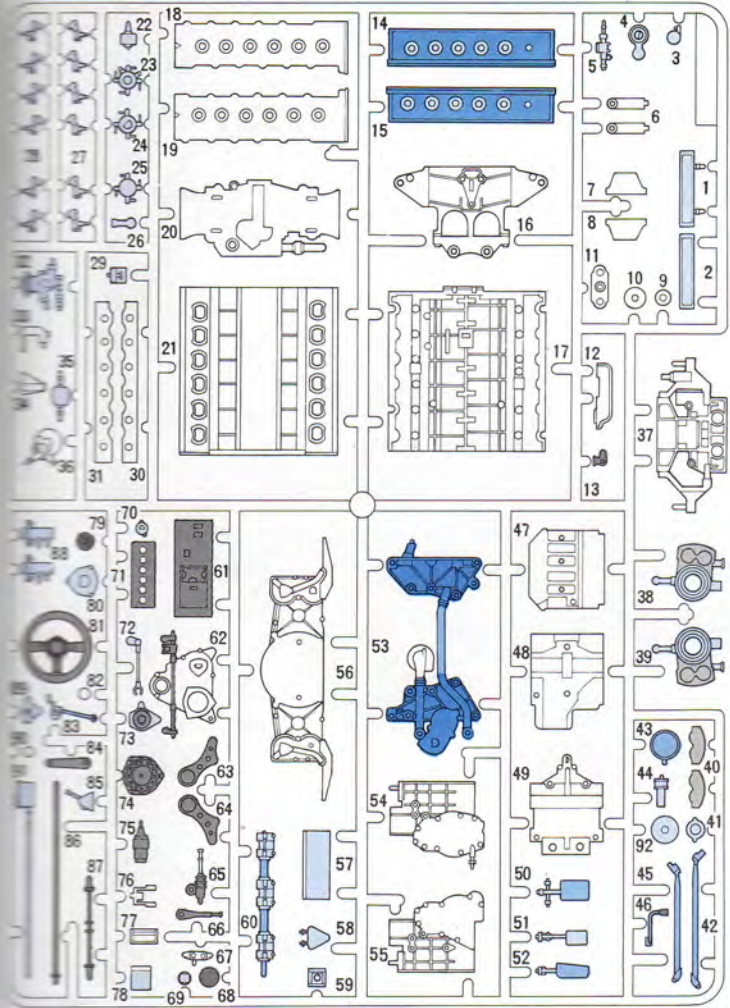

A Parts

-  Aluminum + Orange
-  Lemon Yellow + Aluminium
-  White + Dark Yellow
-  Chrome Silver
-  Aluminium
-  Semi-gloss Black
-  Matt Black
-  Gun Metal



D Parts

-  White
-  White + Chrome Silver
-  Aluminium
-  Chrome Silver (Inside: White)

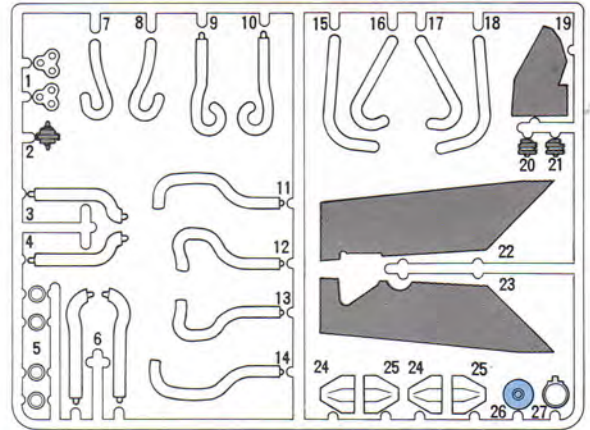

E Parts (Plated)

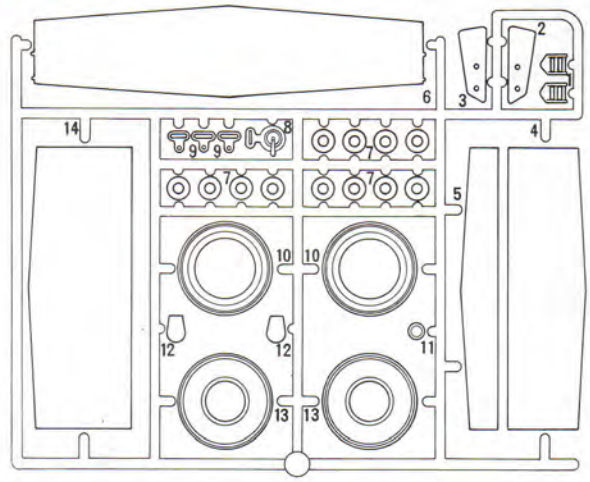

B Parts

-  Aluminium
-  Metallic Grey
-  Chrome Silver
-  White + Dark Yellow
-  Semi-gloss Black
-  Gold
-  Aluminium + Orange
-  Gun Metal

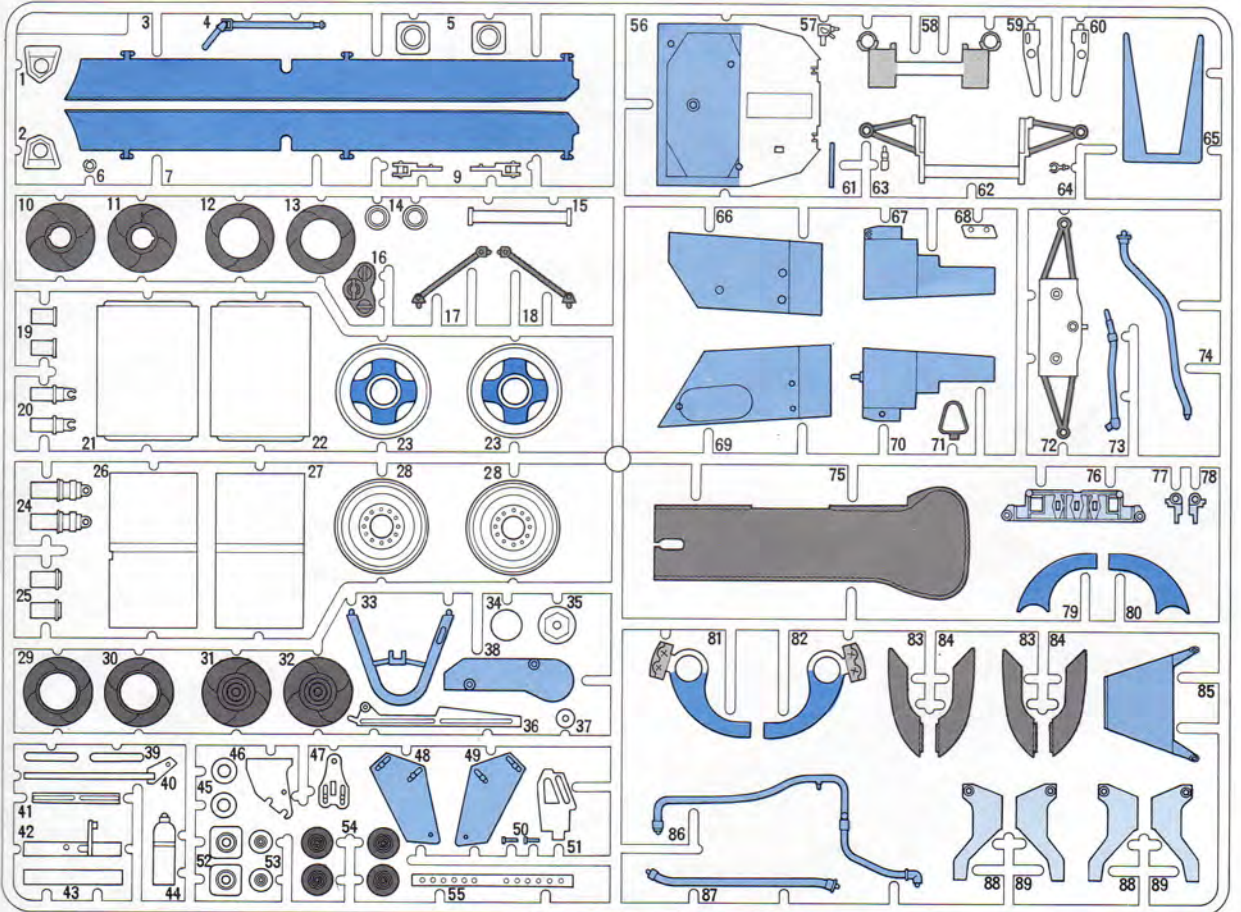

C Parts

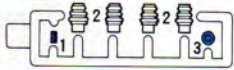

-  Red
-  Orange + White
-  Aluminium
-  Red (Inside: Matt Black)

N Parts  not used

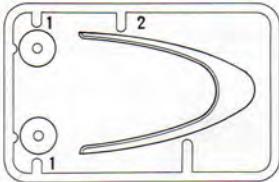

G Parts



F Parts  Semi-gloss Black  Aluminium

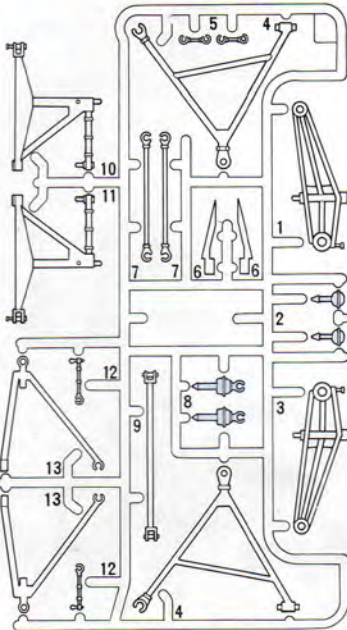

Cockpit Cowling

-  Red

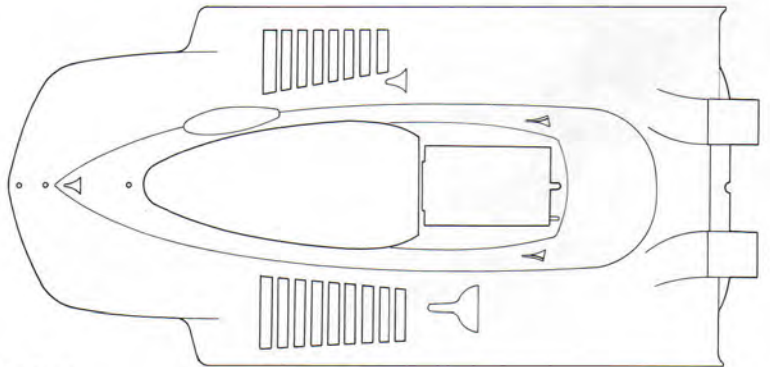

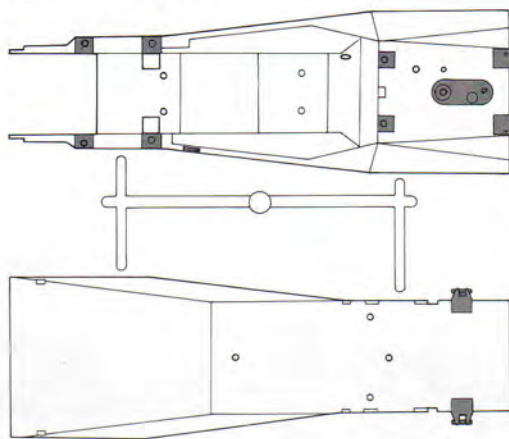

Chassis

-  Chrome Silver
-  Gun Metal

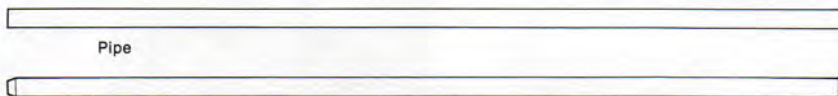

M Parts



 2mm x 4 Countersunk Head Screw  Shaft

 2mm x 4 Screw

 2mm x 6 Screw

 2mm x 10 Screw

 Coil Spring (small)

 Coil Spring (large)

 2mm Nut (large)  2mm Nut (small)

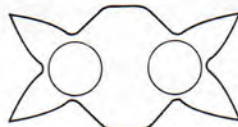

Mesh

- Black Vinyl Tubing (thin)
- Black Vinyl Tubing (thick)
- Black Vinyl Tubing (medium)
- Transparent Tubing
- Vinyl Coated Wire
- Front Tyre
- Rear Tyre
- Decal
- Seat Belt Sticker

BUILD A COLLECTION OF TAMIYA PRECISION CAR MODELS

1/12, 1/20 LOTUS 78 Mk III



1/20 TYRRELL P34 SIX WHEELER

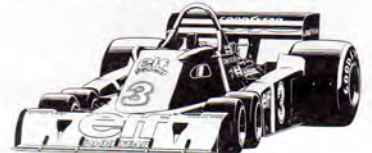

1/20 RENAULT RE30 TURBO

