

HYUNDAI i20 Coupe WRC



Instructions Sheet by Bollier Sylvain

BEL021



"Licensed by Hyundai Motorsport GmbH"
"Hyundai and all other marks, emblems and designs
are intellectual property rights of Hyundai Motor
Company or licensed to it by its partners"

**1/24
SCALE**



BELKITS
www.belkits.com

BELKITS – THE HISTORY OF OUR “BELGIAN KITS”

With Dominomodel's headquarters just 10 kilometres from the heart of the famous Ypres rally, and having a Super Stage (Westouter) close to our shop, you can say that rally is in our blood. We started selling diecast rally cars in our shop in the early 90's, slowly expanding the range with a large collection of old and modern rally model kits, paints, decals and accessories. In the beginning of the years 2000, suddenly for a few years there weren't any new rally model kits on the market, but we still had a huge demand for those. That is the moment we began to dream about our own line of rally model kits.

We first started with some smaller projects, like our resin series of the Citroën C2 by Loix (in cooperation with Renaissance) and also a reproduction of the Ford Escort RS Cosworth. In the meanwhile, still dreaming about our own plastic injected line of rally kits, we finally met the right people. That's when our dream became reality: we launched the brand name BELKITS and we were able to commercialize our first kit: BEL 001, the Peugeot 207 from Kris Meeke, the Ypres Westhoek Rally Winner of 2009.

From there on, we moved forward slowly - because we really make the kits with our rally heart - but surely, and in about 10 years we brought 18 different old and modern rally kits on the market. Since our very first release as a brand with the main office in Belgium, it was our wish to have a Belgian pilot in our range to make the connection complete! Because even though we are a small country, we do have a long history of well-known rally's and world famous-rally pilots. When we got close to the 10th anniversary of our brand, the pieces of the puzzle fell together and we got the license for this Hyundai I20 from Neuville, winner of the Tour De Corse 2019. We really hope you all enjoy building this car and we will continue with more rally model kits so your stashes never get empty!



READ BEFORE ASSEMBLY.
LIRE AVANT L'ASSEMBLAGE.
EERST LEZEN VOOR MONTAGE.

⚠ Opgelet

Niet geschikt voor kinderen jonger dan 14 jaar.
Bevat kleine onderdelen.
Een toezichhoudende volwassene moet de instructies lezen, als een kind het model monteert.
Voor het samenstellen van deze set is gereedschap nodig.
Wees extra voorzichtig om letsel te voorkomen.

⚠ Précautions

Ce produit ne convient pas à un enfant de moins de 14 ans.
Contient de petites pièces.
La construction du modèle par un enfant doit s'effectuer sous la surveillance d'un adulte.
L'assemblage du modèle requiert des outils.
Utilisez-les avec précaution pour éviter toute blessure.

⚠ Caution

Not suitable for children under 14 years.
Contains small parts.
A supervising adult should read the instructions if a child assembles the model.
Assembling this kit need tools.
Extra care should be taken to avoid injury.

TOOLS REQUIRED

- SIDE CUTTERS 

- HOBBY KNIFE 

- DECAL SOFTNER 

- DRILLS 

- TWEEZERS 

- PLASTIC CEMENT
CYANOCRYLATE GLUE 

COLORS REQUIRED

TAMIYA

N5 COLORS

TAMIYA

N5 COLORS

I20 WRC Blue Pantone 277C	/	C043	Titanium Silver	X-32	/
Luminous Red Pantone 2347C	/	X015	Bronze	X-33	/
Night Blue Pantone 654C	/	X047	Flat Black	XF-1	X011
Gloss Aluminium	TS-17		Flat Aluminium	XF-16	X010
Silver	TS-30	/	Medium Gray	XF-20	/
Light Gun Metal	TS-42	/	Dark Copper	XF-28	/
Gloss White	X-2	X001	Neutral Gray	XF-53	/
Orange	X-6	X022	Metallic Gray	XF-56	/
Gloss Red	X-7 / TS-49	X037	Rubber Black	XF-85	/
Gun Metal	X-10	X018	Flat Light Brown	XF-93	/
Silver	X-11	/	Pure Blue	LP-6	/
Gold Leaf	X-12	/	Pure Red	LP-7	/
Semi-Gloss Black	X-18 / TS-29	/	Pure Orange	LP-51	/
Flat Base	X-21	/	Gloss Aluminium	LP-70	/
Titanium Gold	X-31	/	Flat Blue Mat	LP-78	/

DECALS APPLICATION

- Cut off the decal from sheet.
Dip the decal in water for 10 to 20 seconds.
- Place the decal on the desired place, hold the backing sheet edge and slide the decals onto the model
- Adjust the decal position and dry the excess water with a soft cloth.
- We recommend to use a decal softener for the difficult surfaces.

- Découpez la décalcomanie de la feuille.
Plongez la décal dans l'eau pendant 10 à 20 secondes.
- Placez la décal à l'endroit prévu, tenez le bord de la feuille de support et faites glisser la décalcomanie sur le modèle.
- Ajustez la position de la décal et séchez l'excédent d'eau avec un chiffon doux.
- Nous recommandons d'utiliser un adoucisseur de décal pour les surfaces difficiles.

A Parts

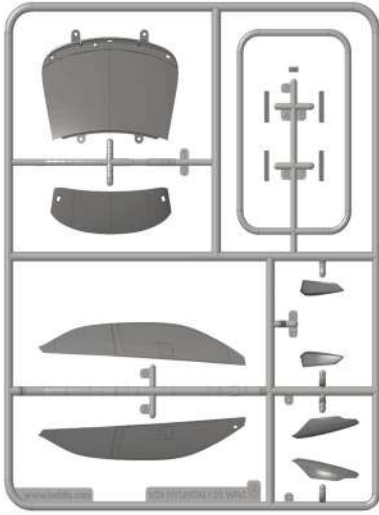

B Parts

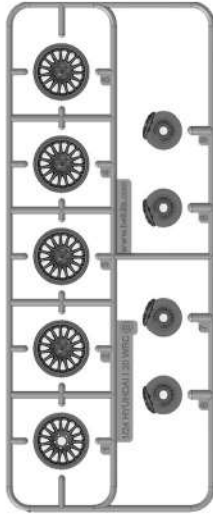

C Parts

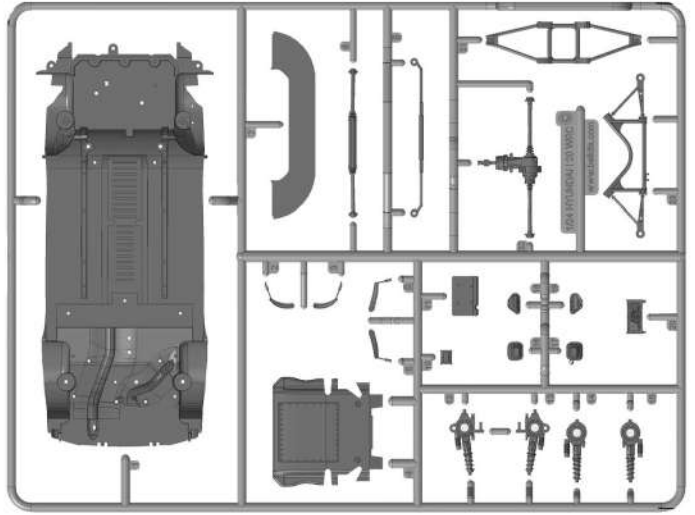

D Parts

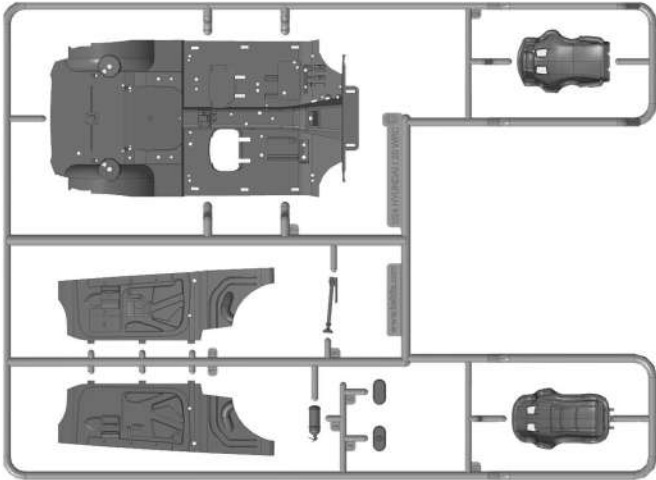

E Parts

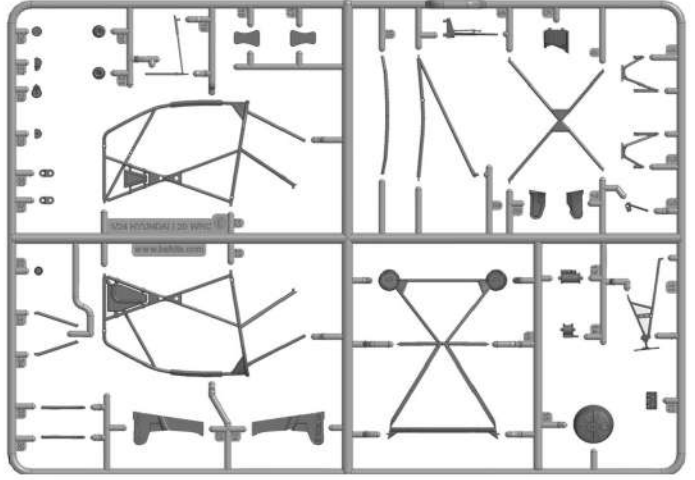

J Parts

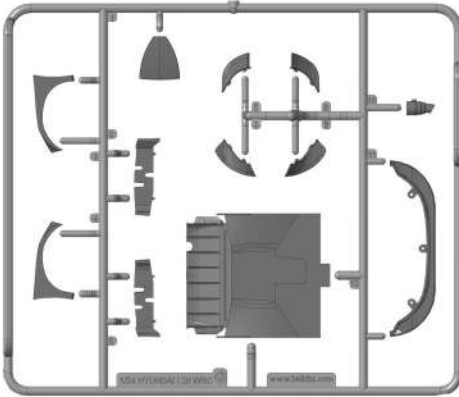

K Parts



F Parts

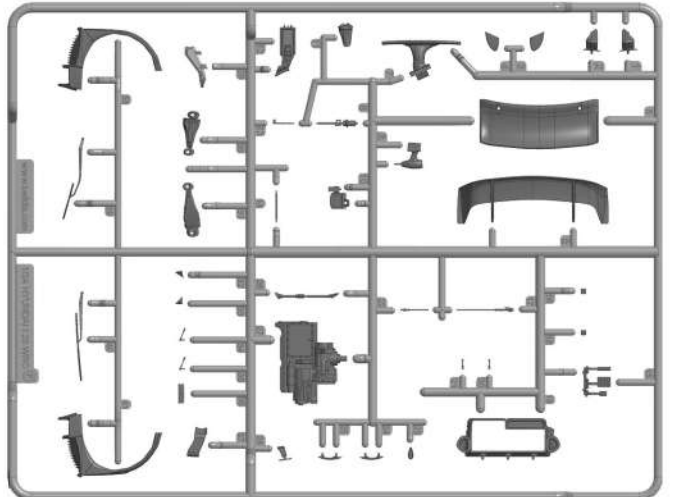

PE Parts

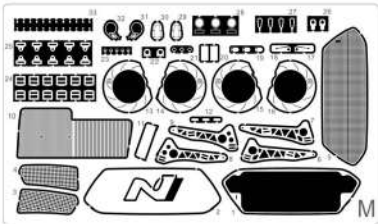

Tires



Body

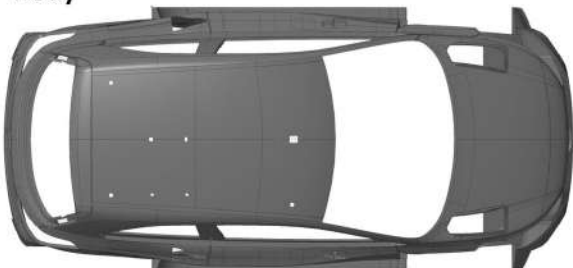

H Parts

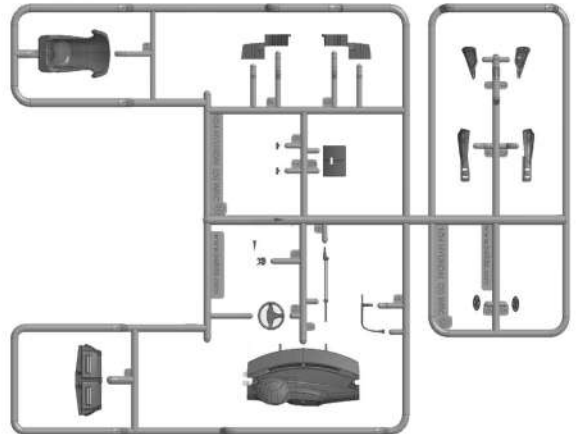

1

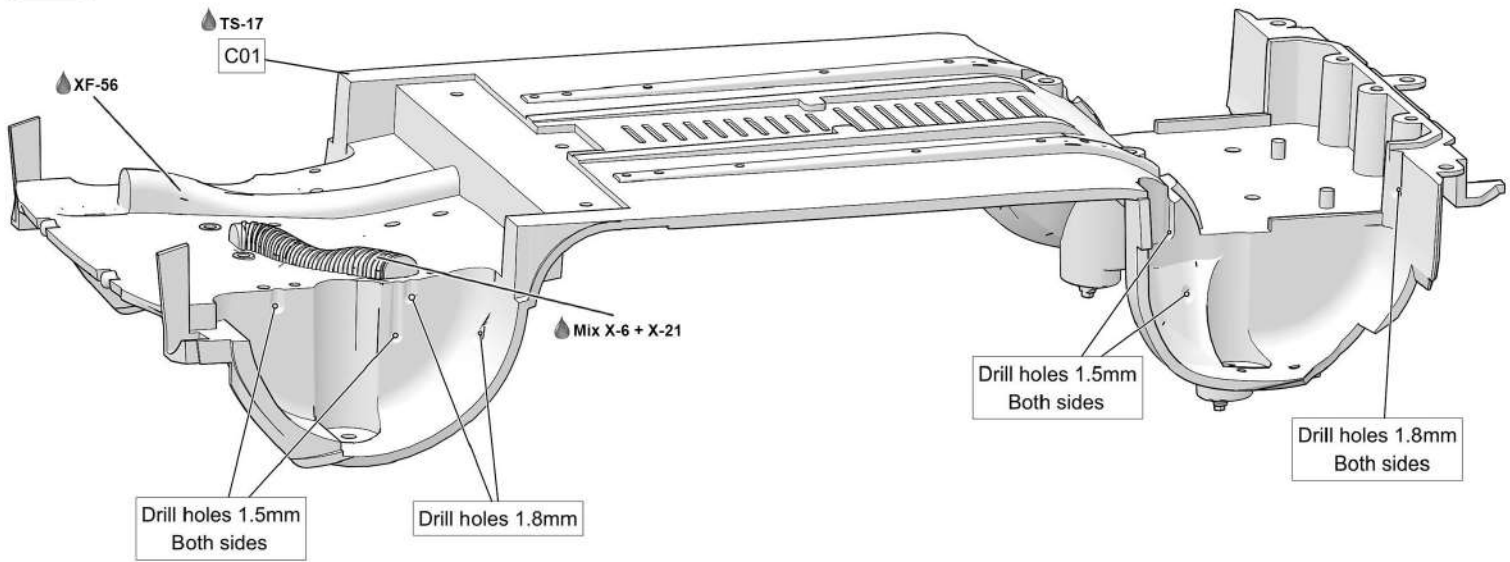

2

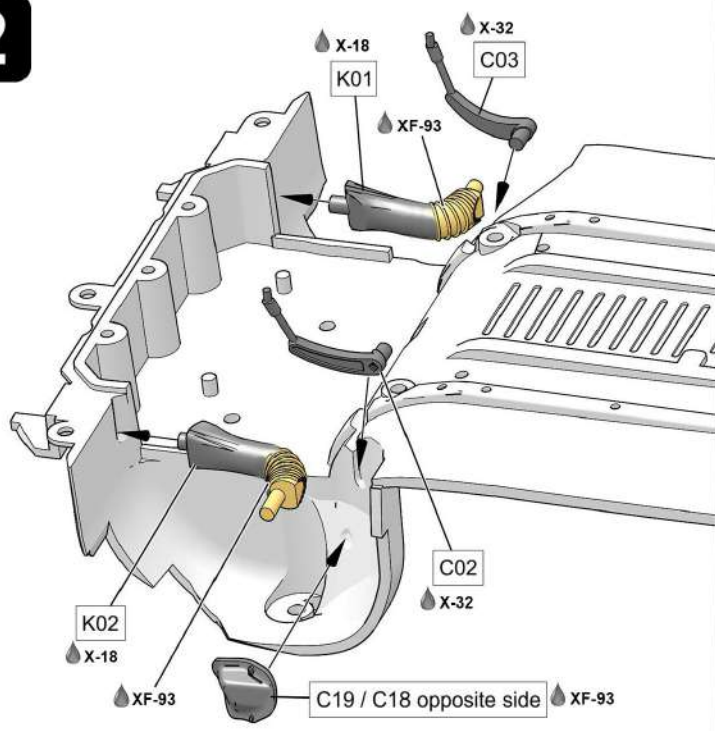

3

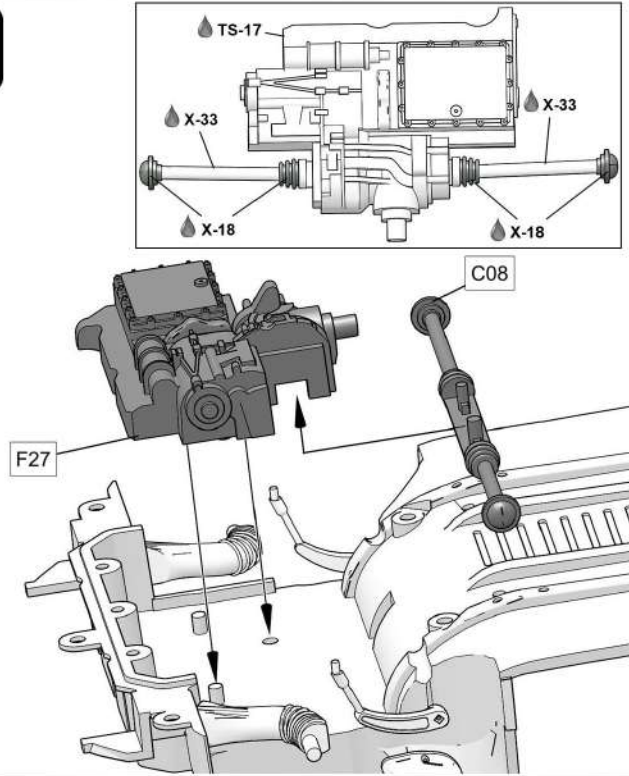

4

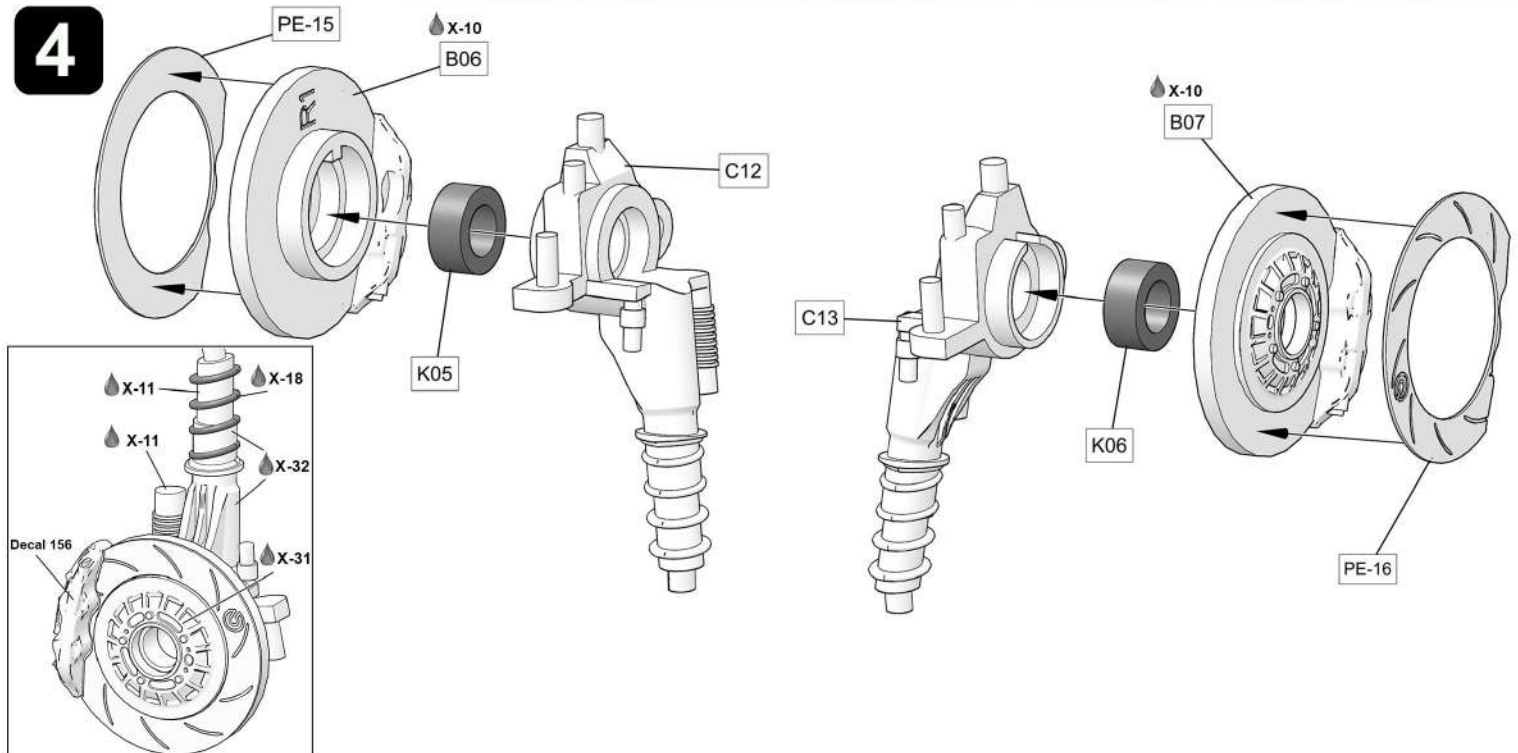

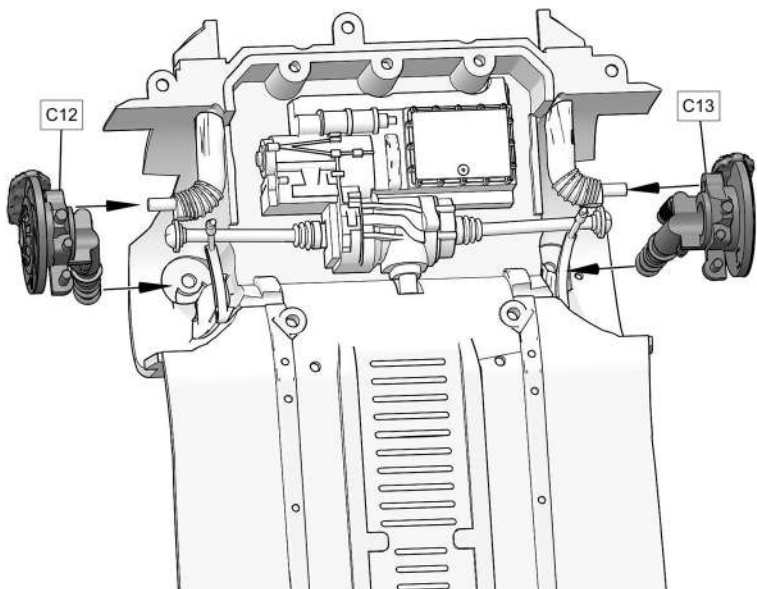
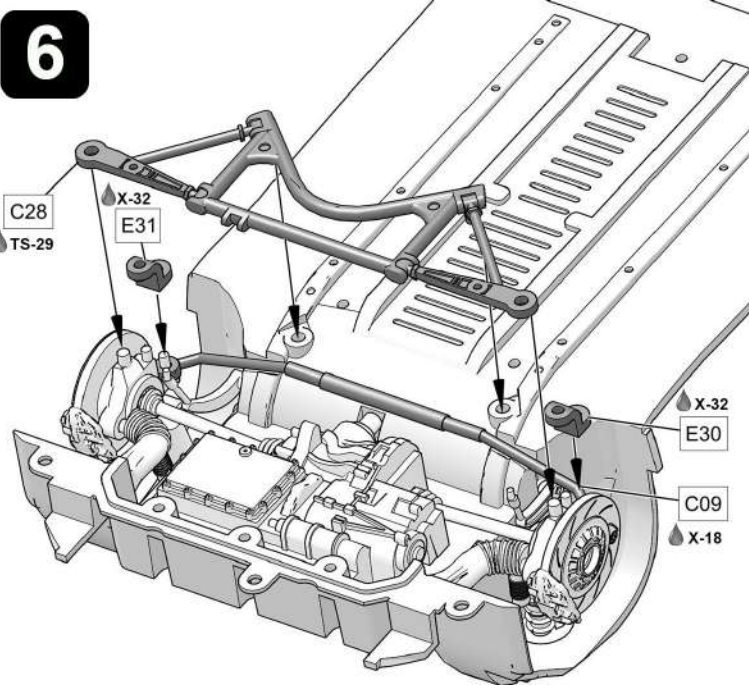
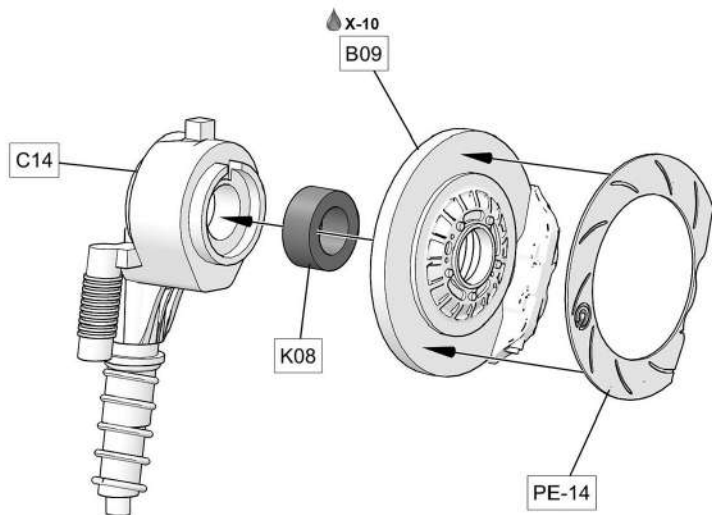
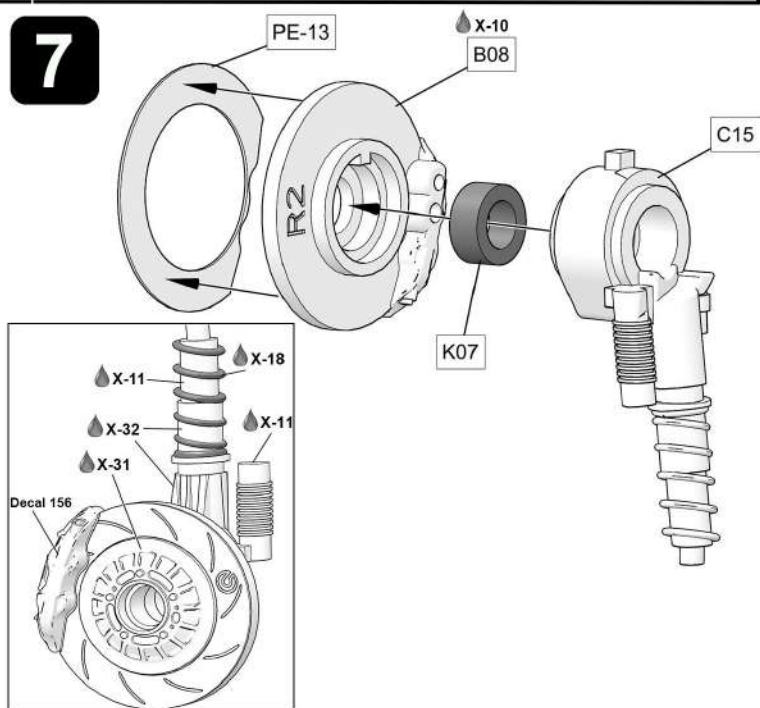
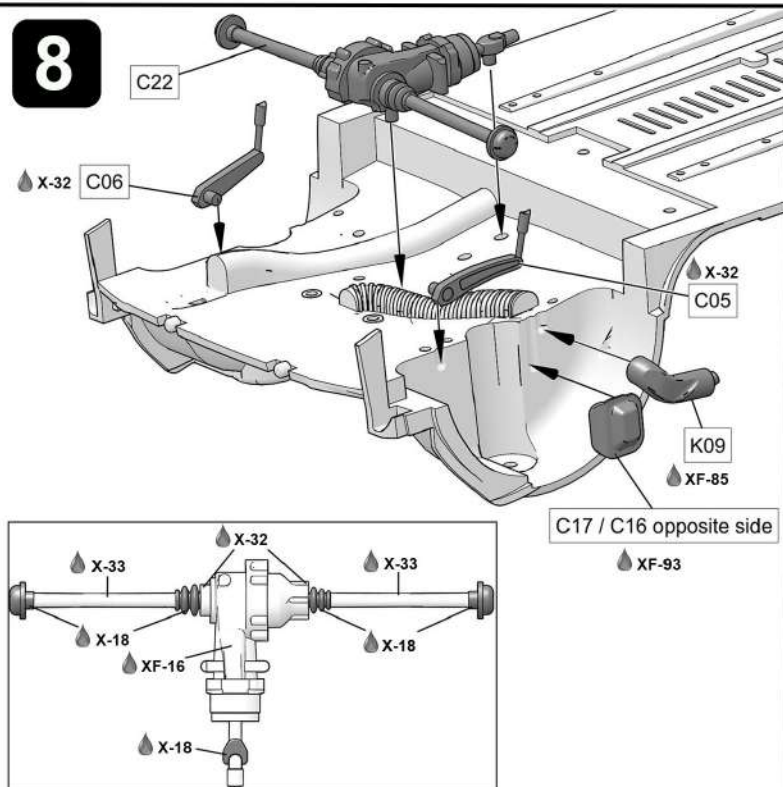
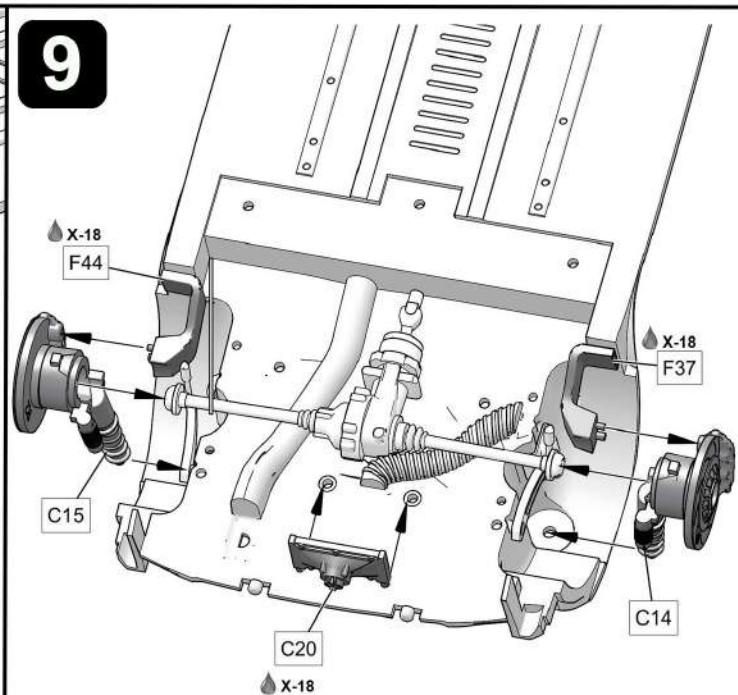
5**6****7****8****9**

10

⚠ Glue E01/E02 after step 11

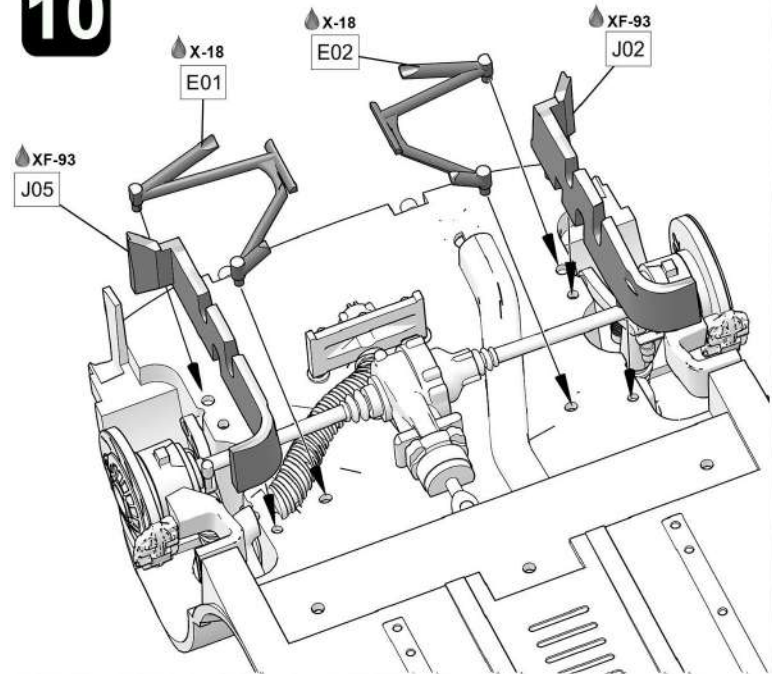

11

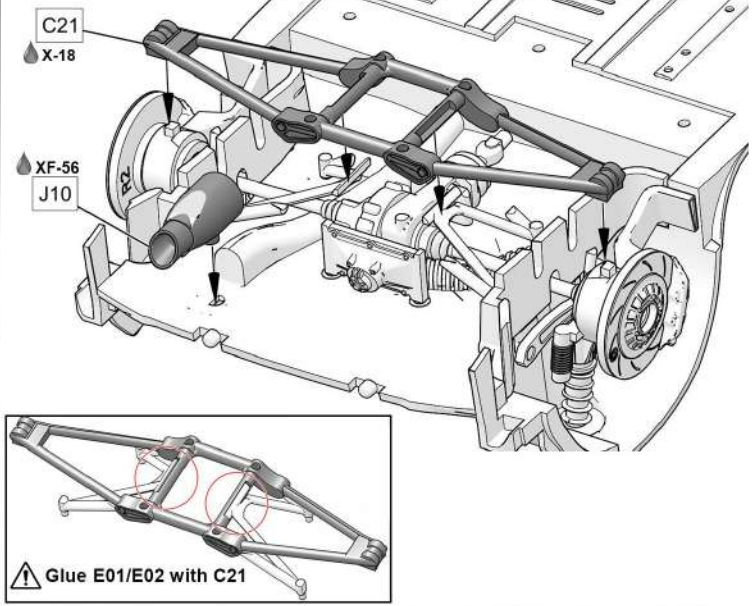

12

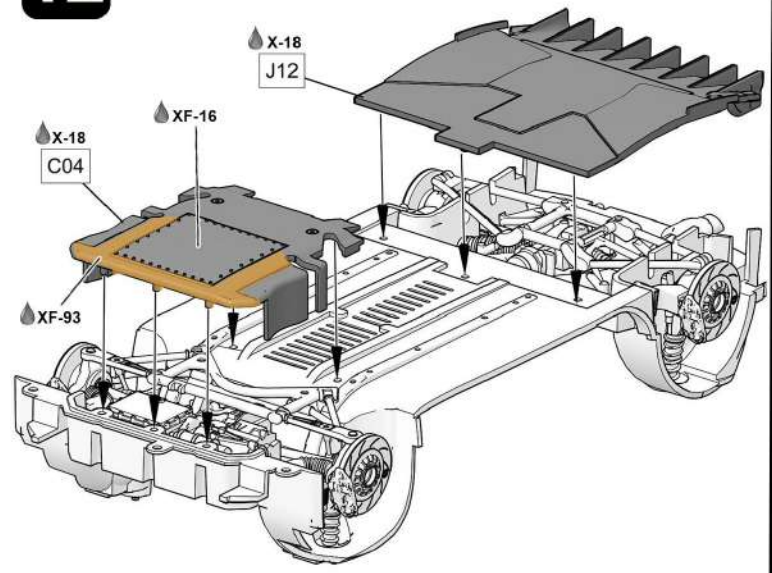

13

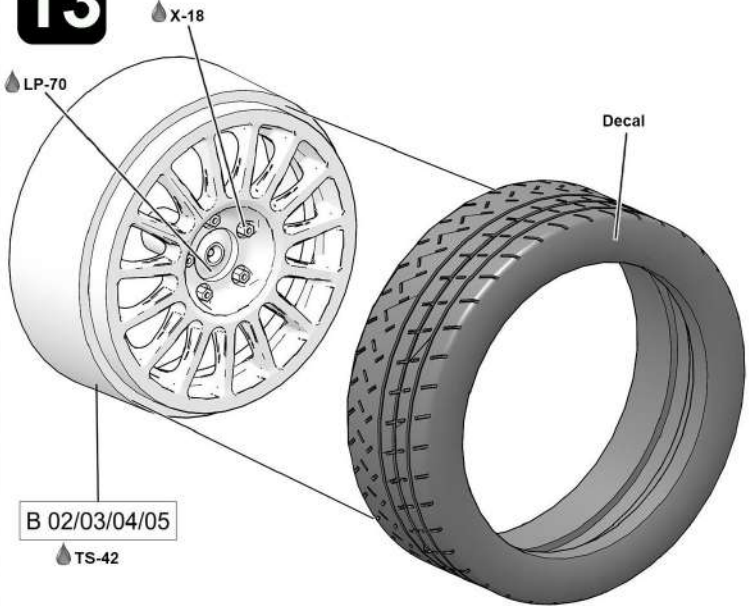

14

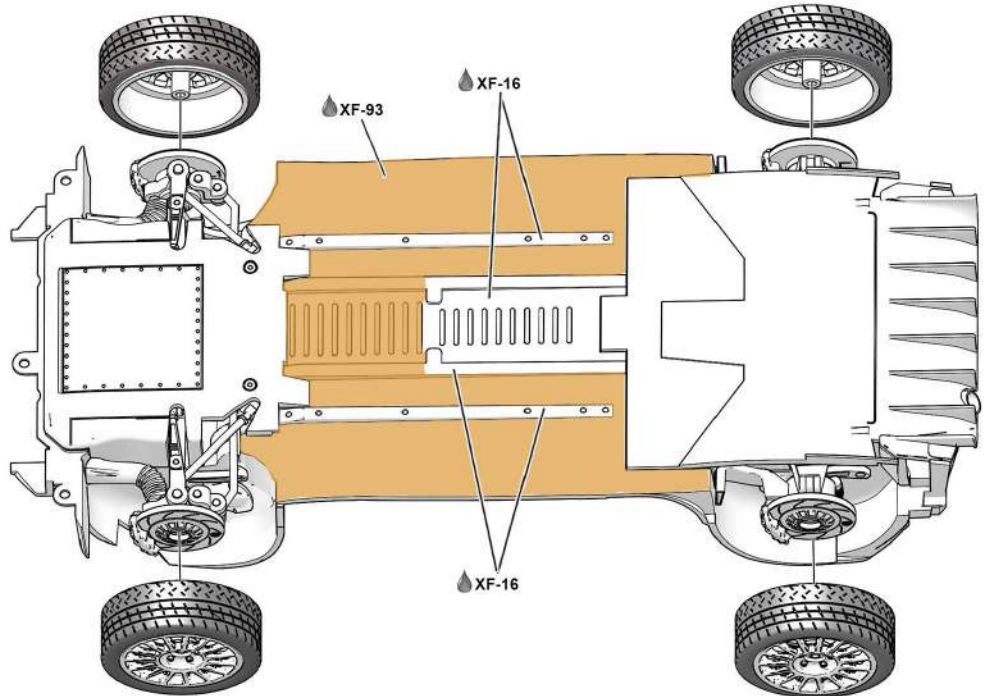

15

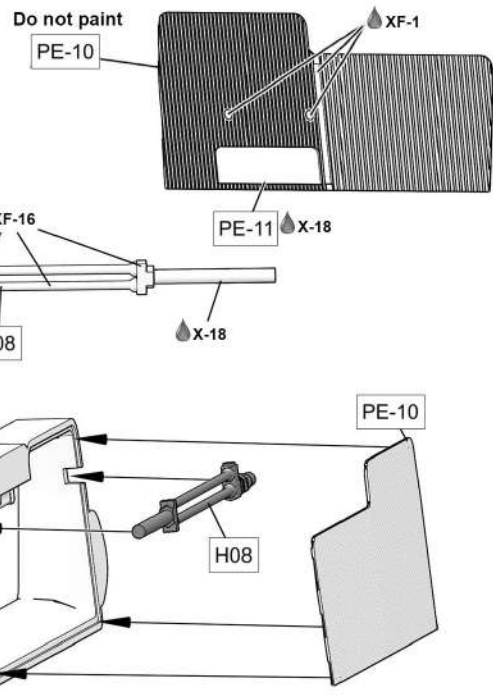

16

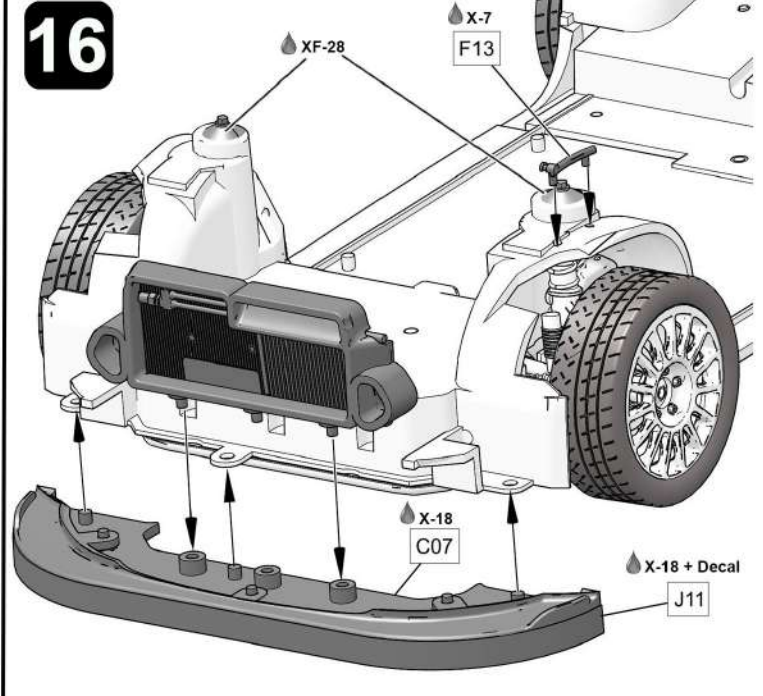

17

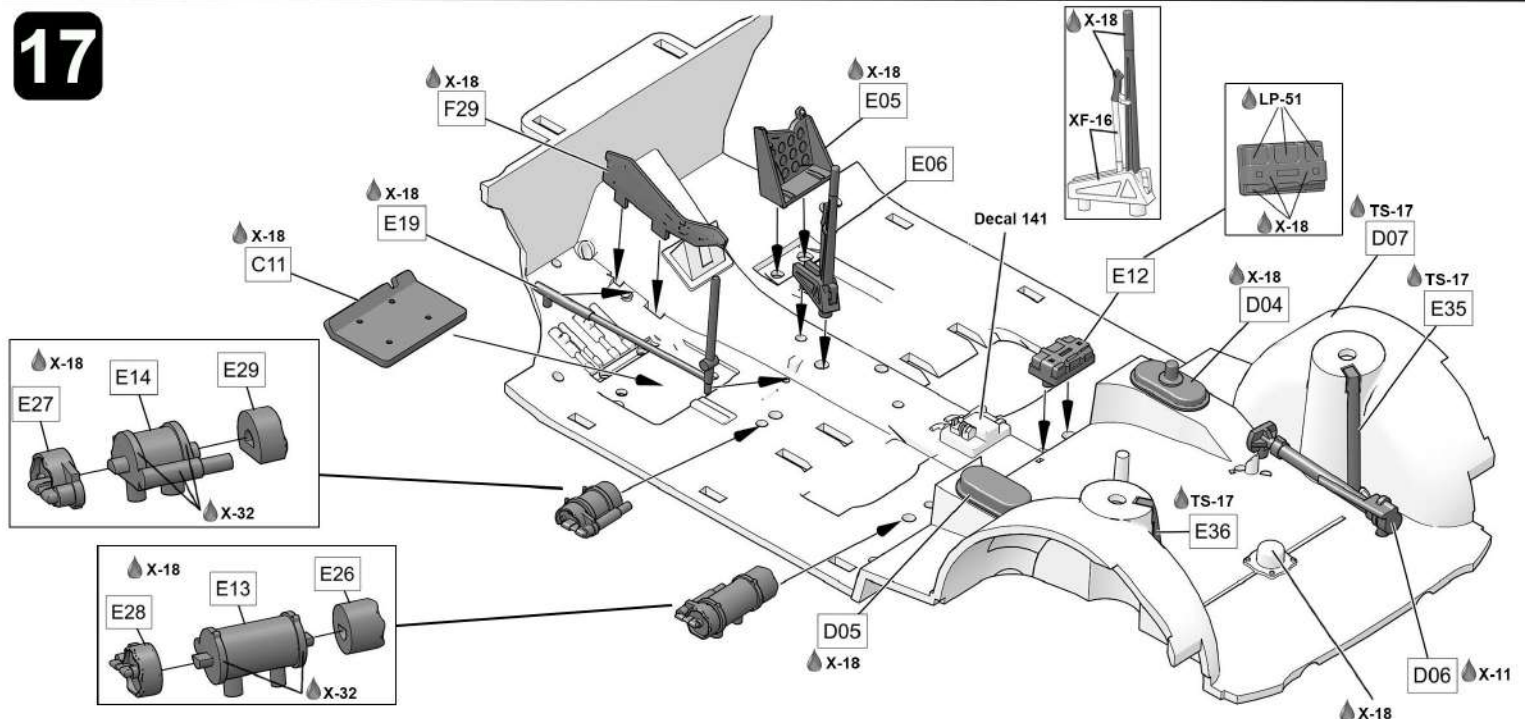

18

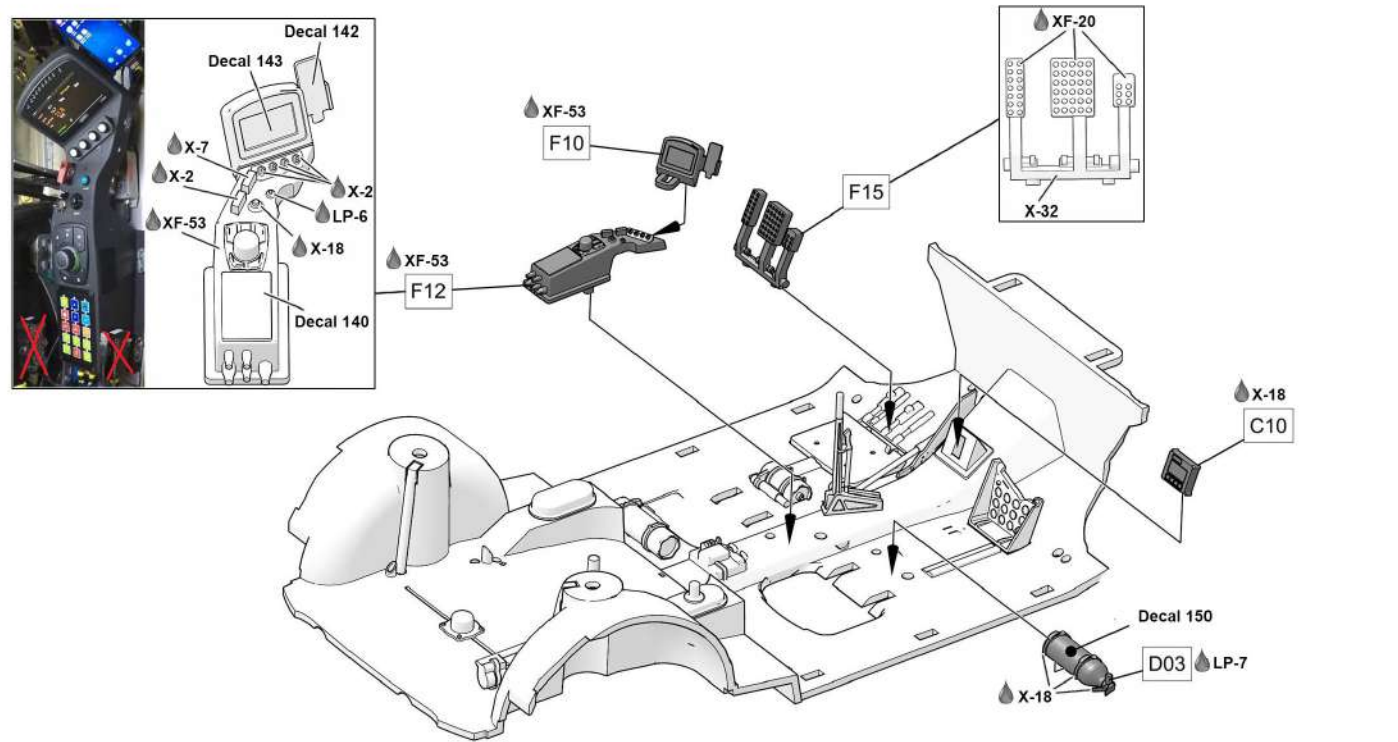

19

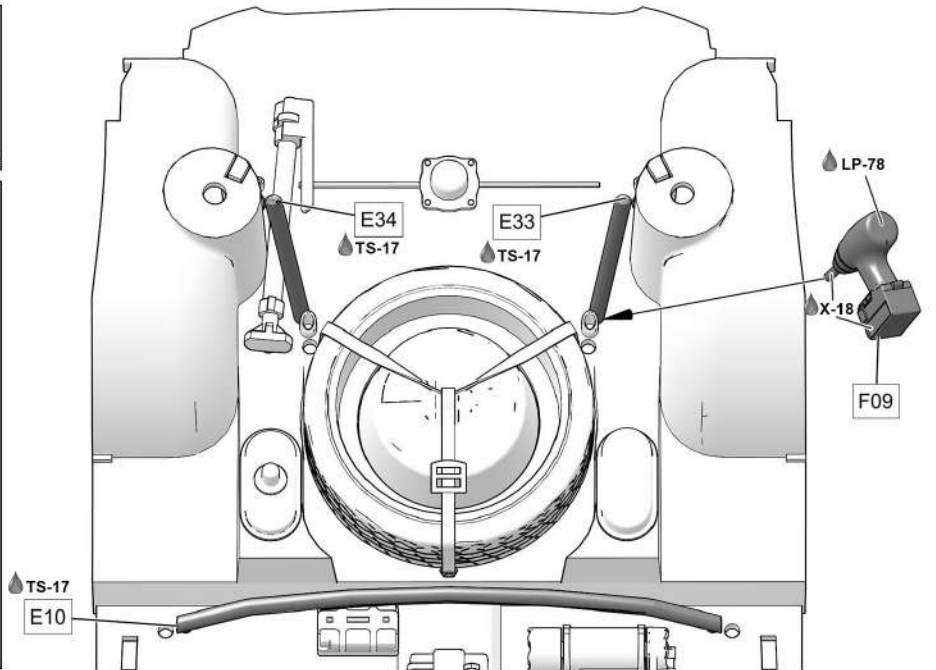
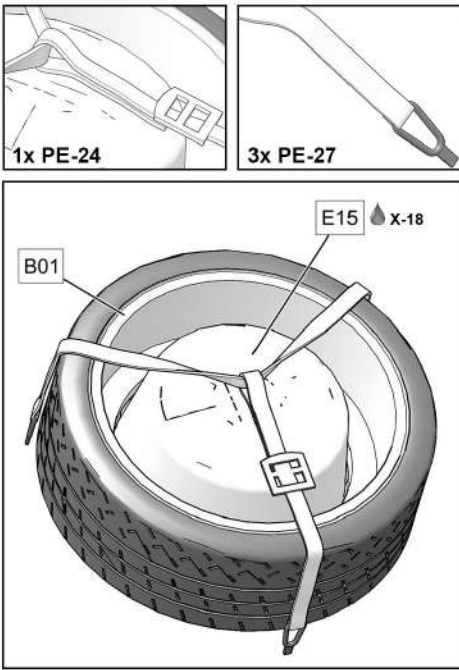

20

DRIVER SEAT

⚠ Paint first the seat before applying the decals

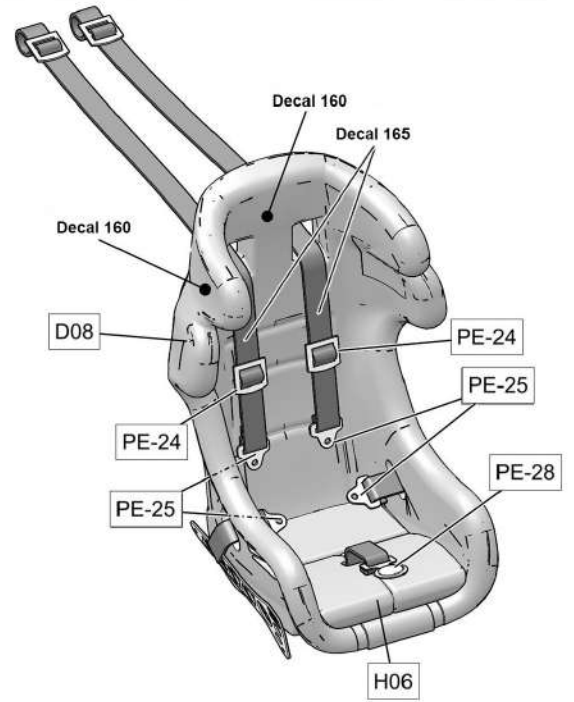
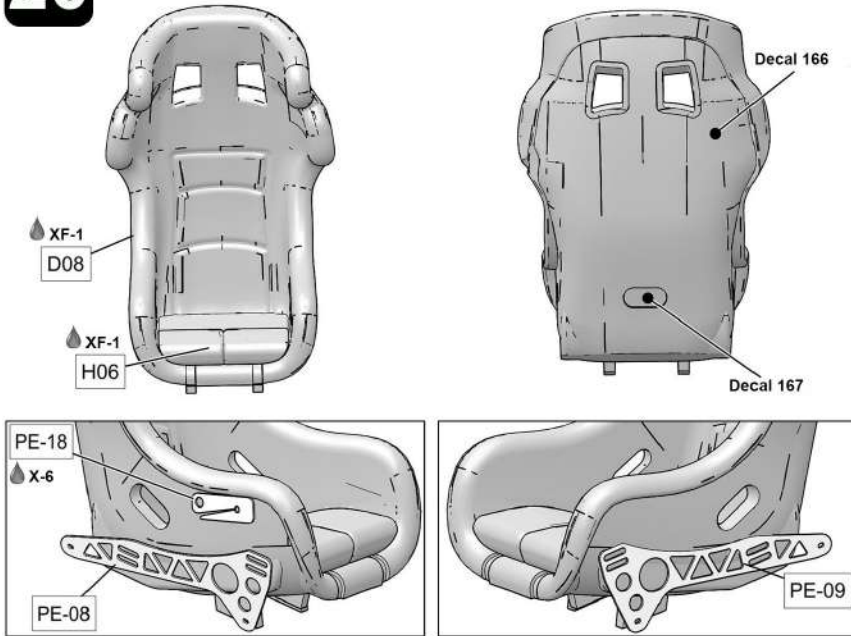

21

CO-DRIVER SEAT

⚠ Paint first the seat before applying the decals

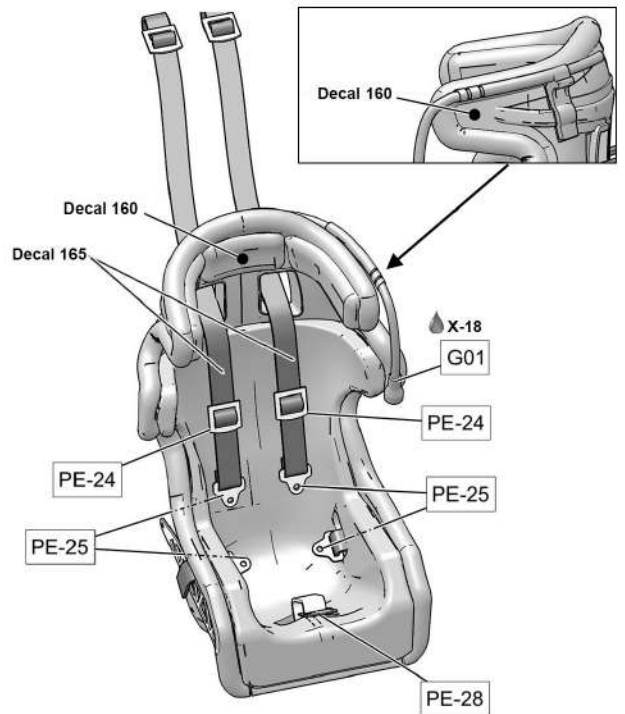
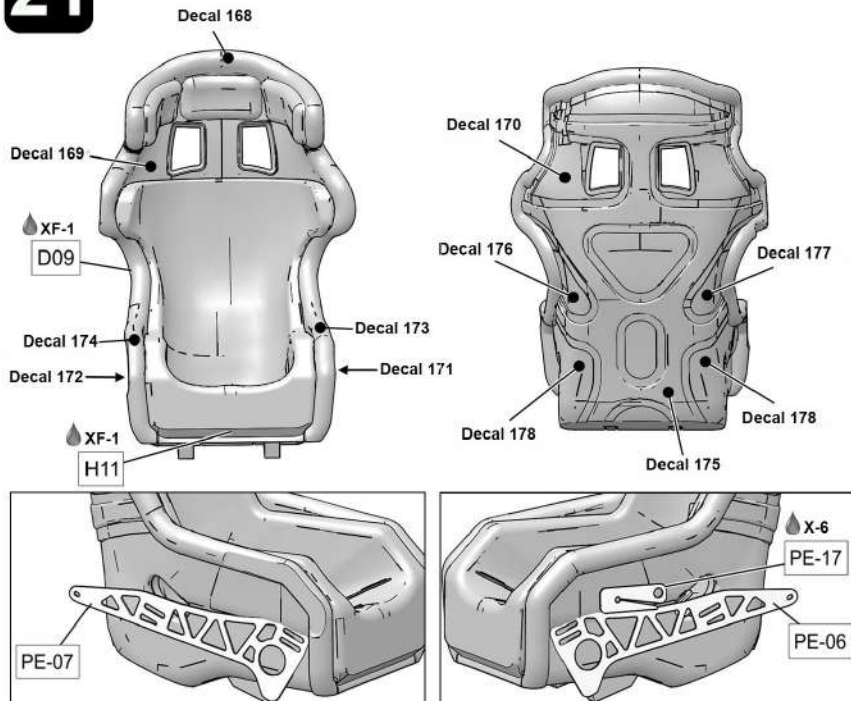

⚠ First paint the doors panels in TS-29

DOOR PANEL LEFT

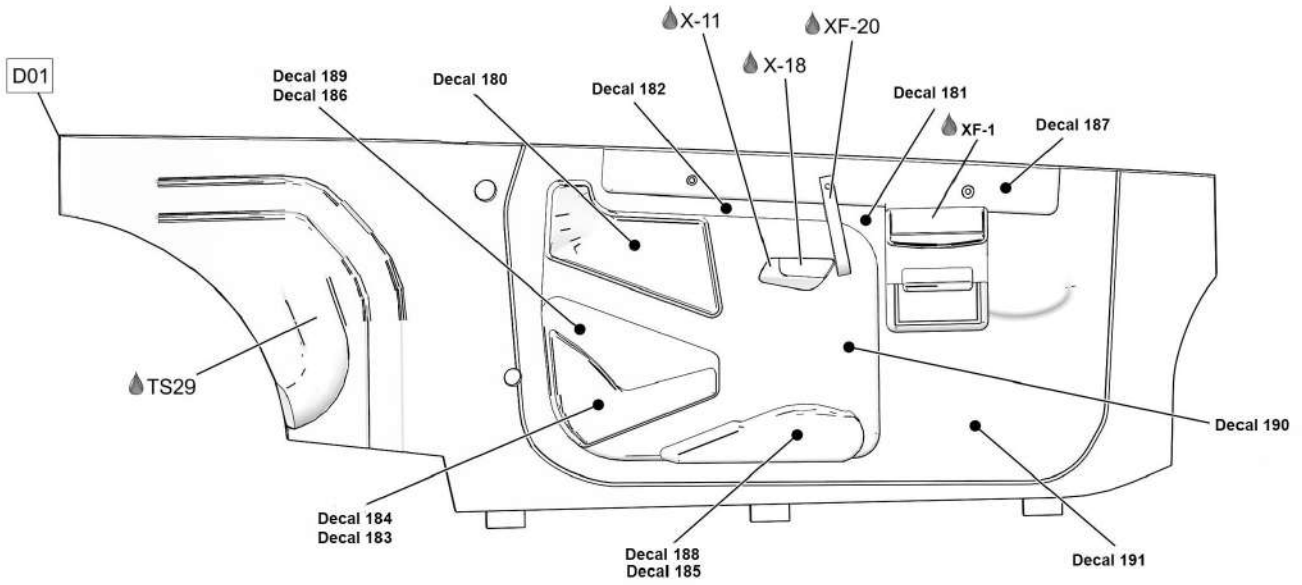

DOOR PANEL RIGHT

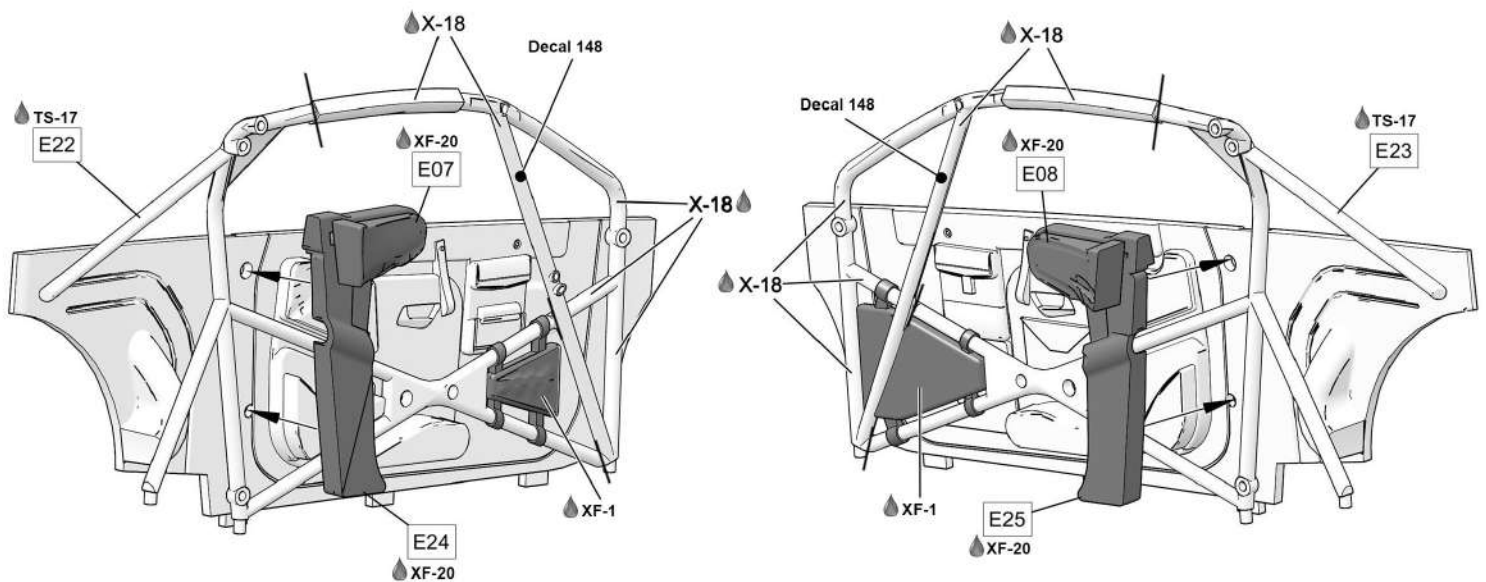
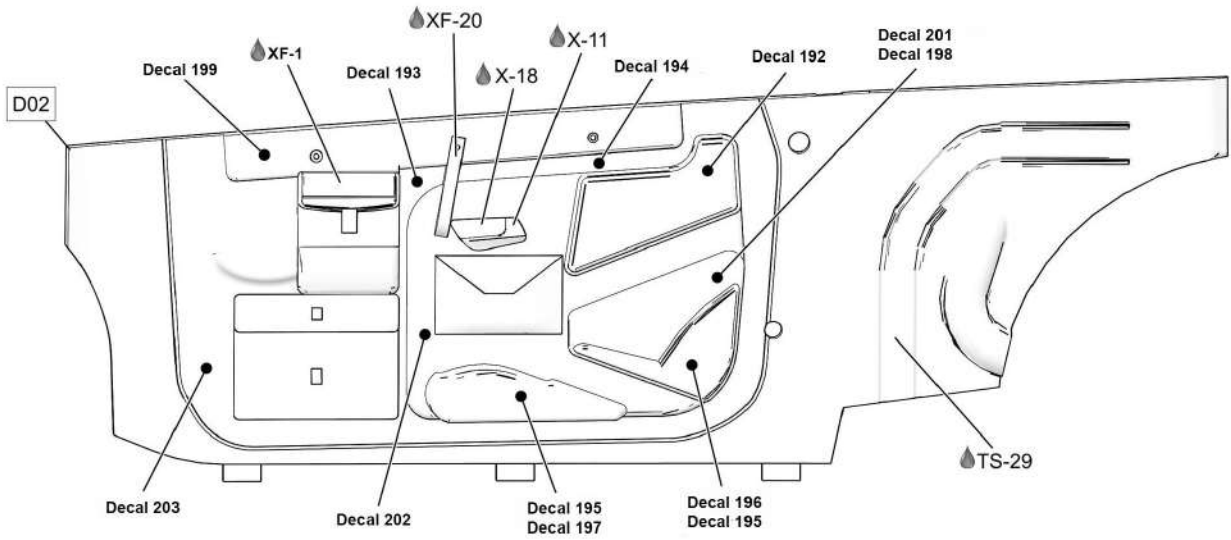

24

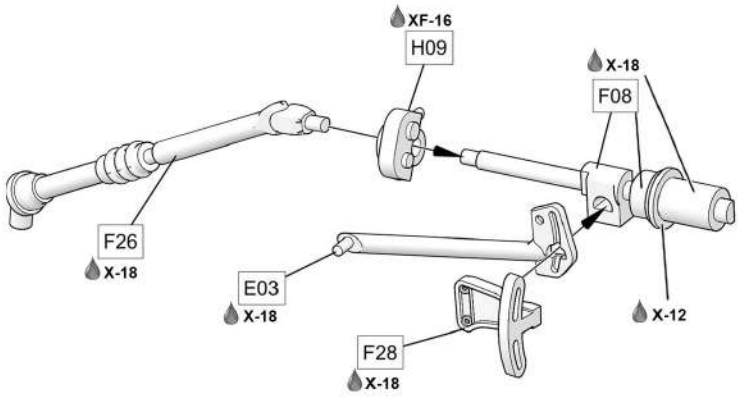

25

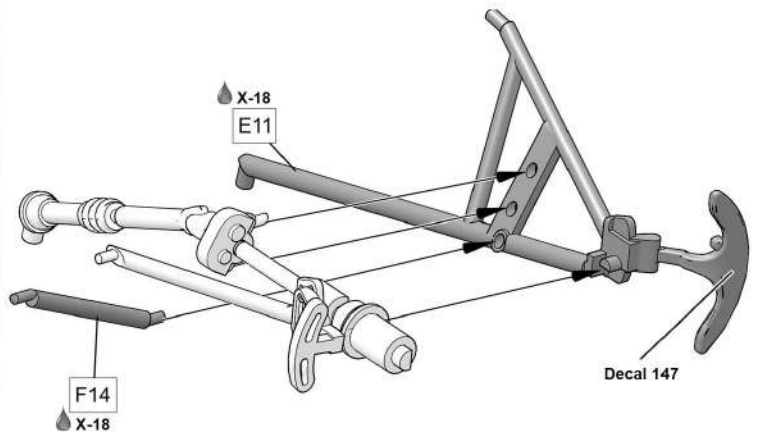

26

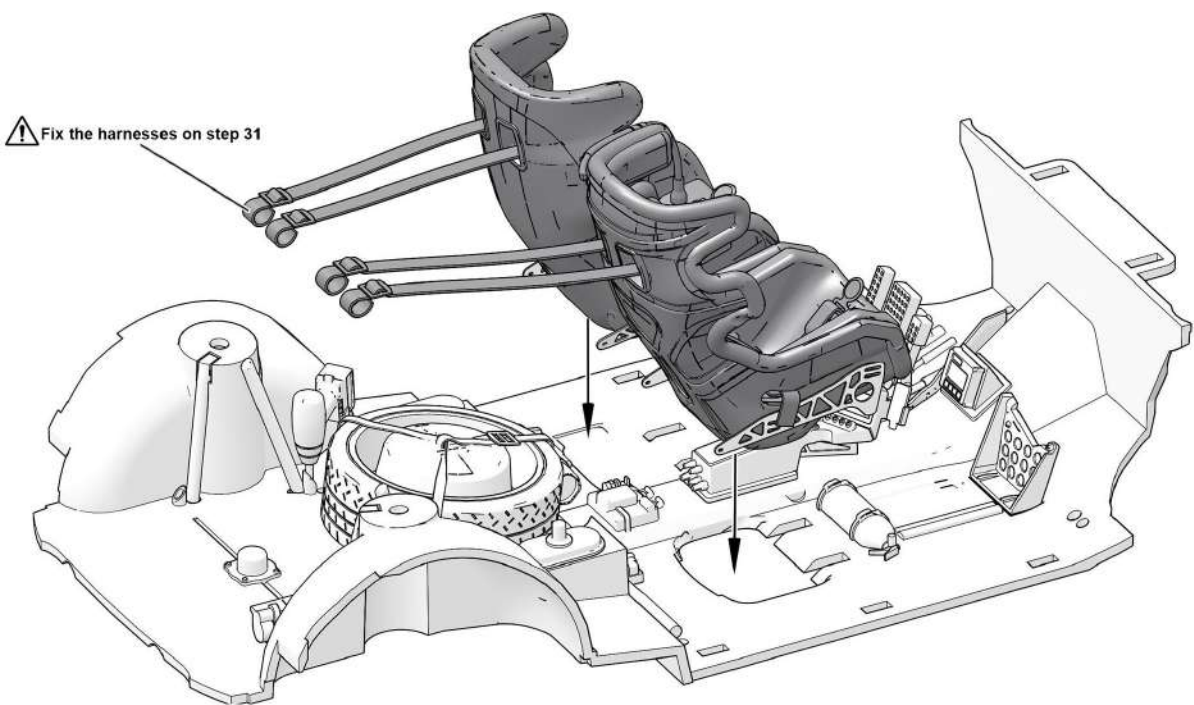

27

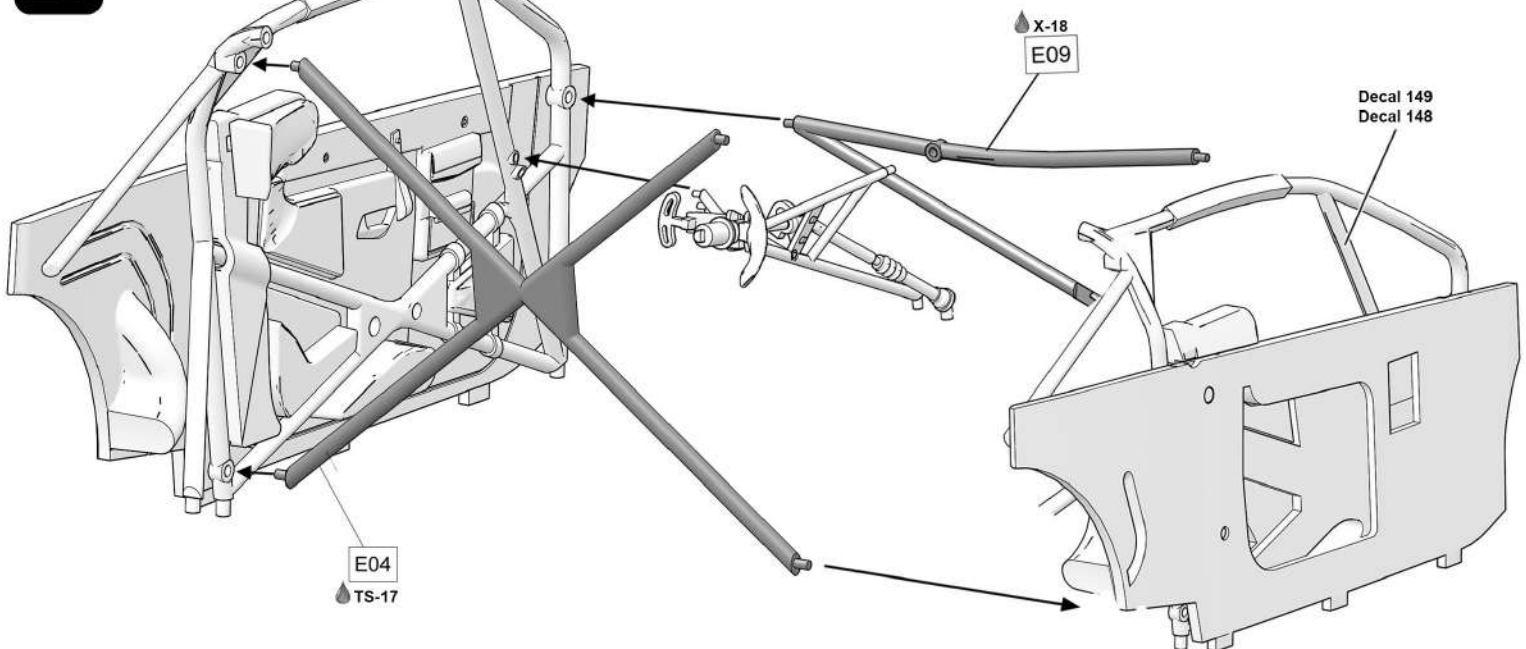

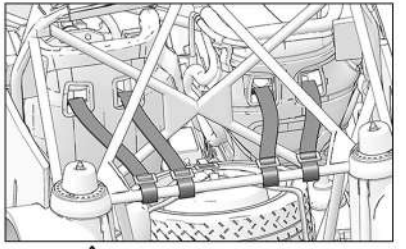
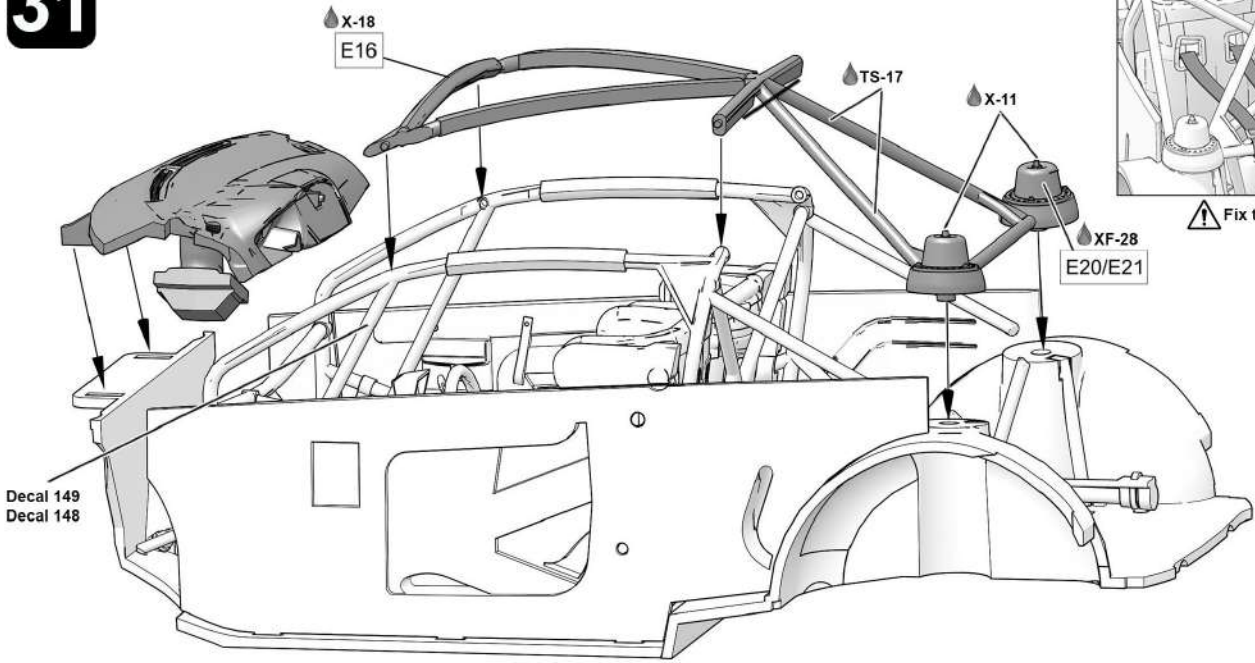
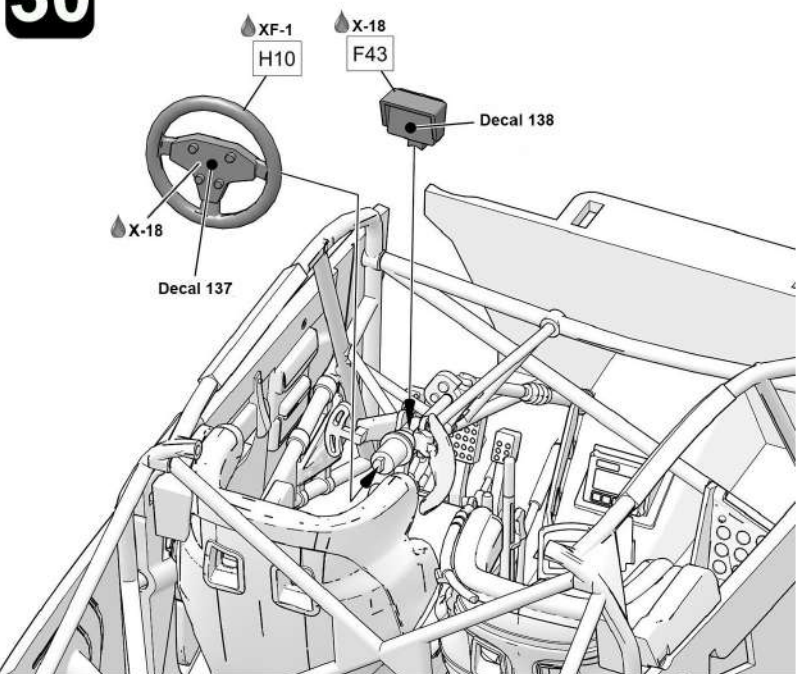
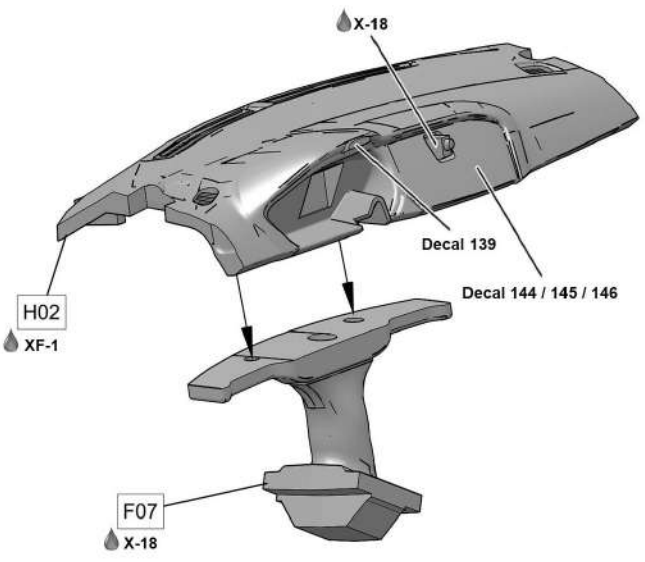
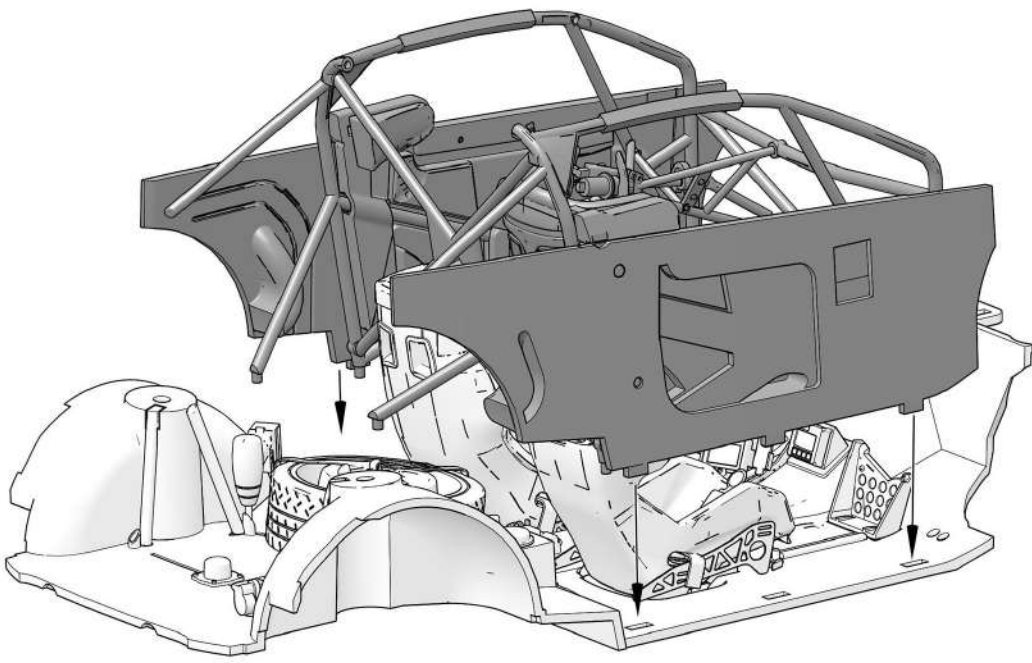

⚠ Fix the harnesses to the bar

32

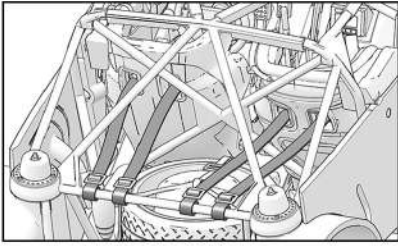

! Fix the harnesses to the bar

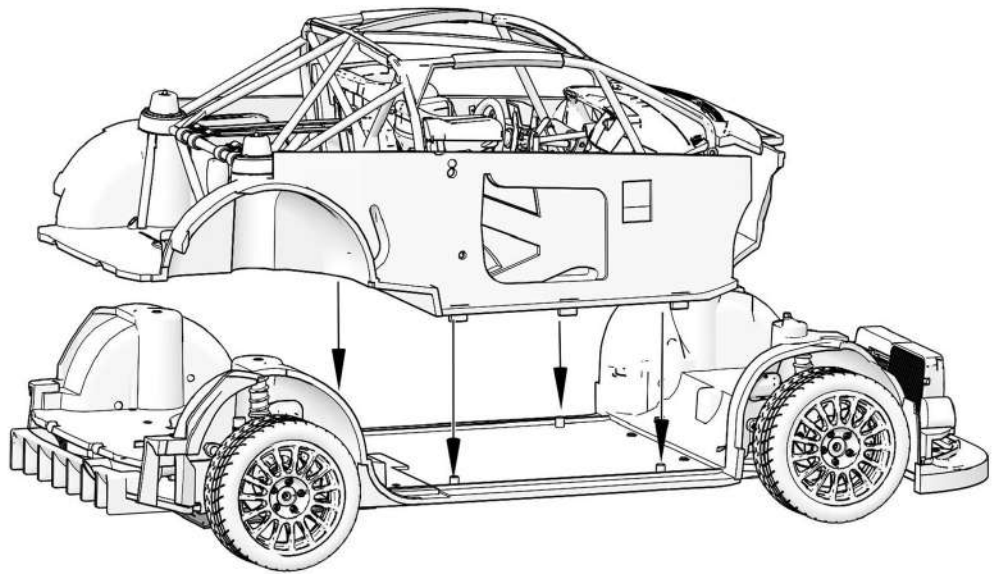

33

! Before assembly: use the windows masking to paint in black from inside

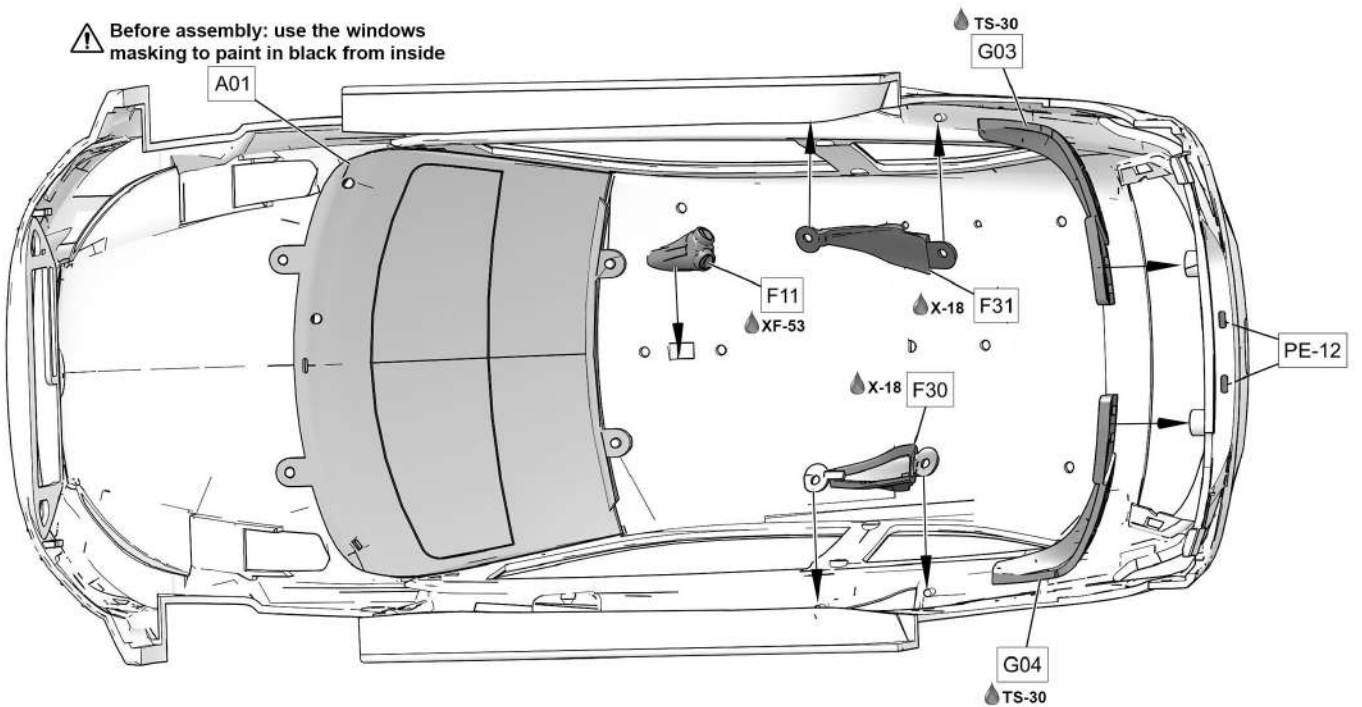

34

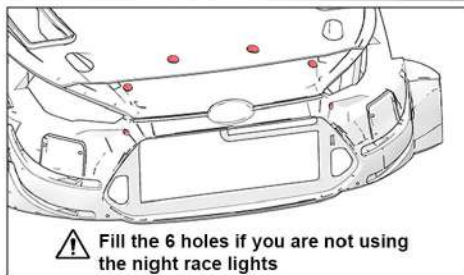

! Step 1: paint the headlights in TS-30 before applying decals
 Step 2: apply the carbon decals 76 / 73
 Step 3: apply the decal 80 / 79 over the carbon

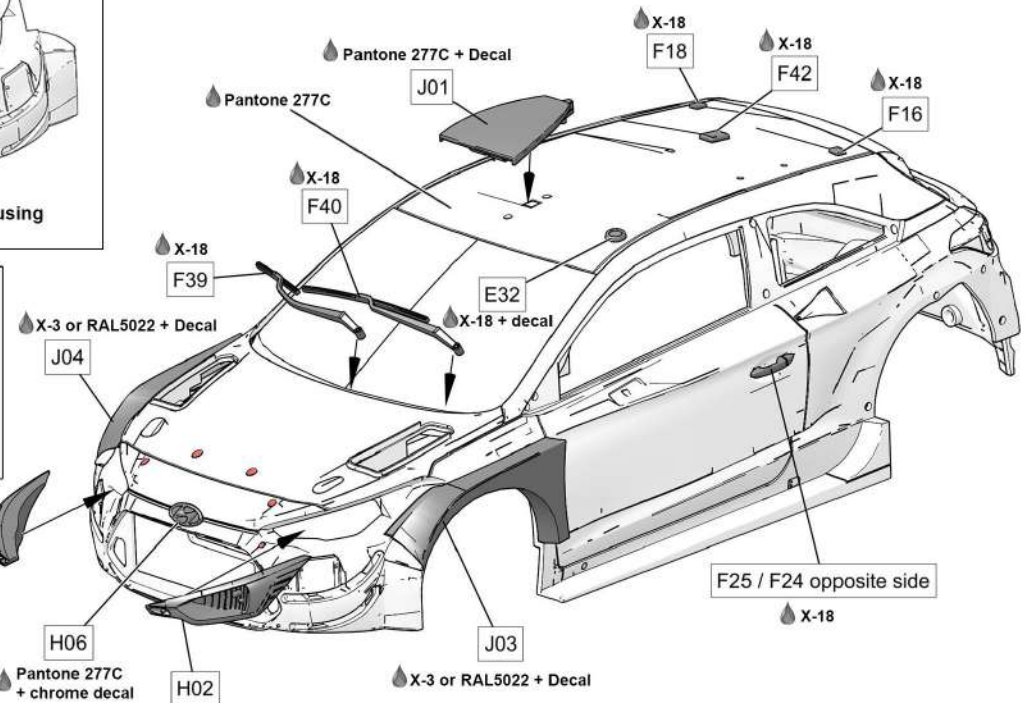
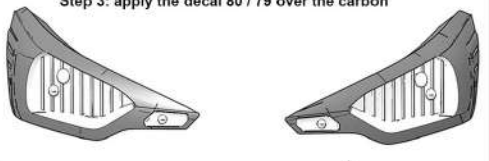

35

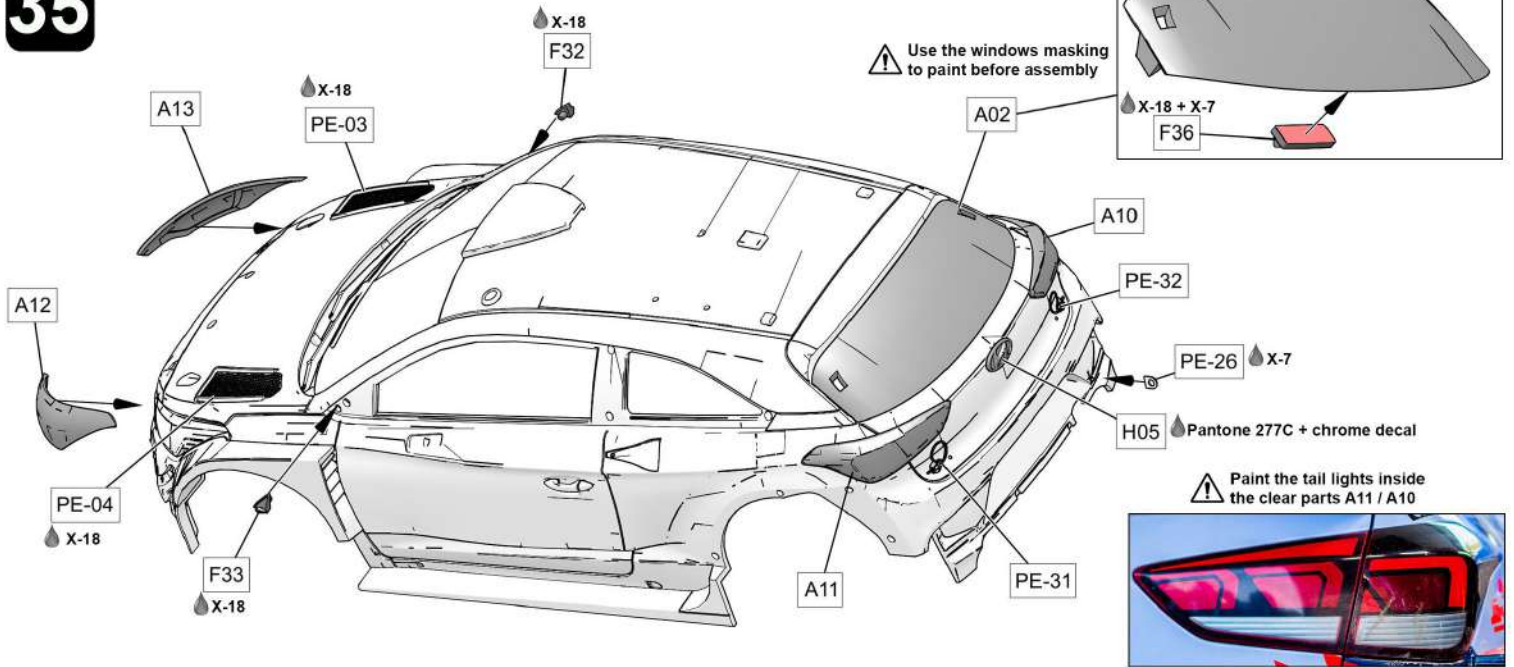

36

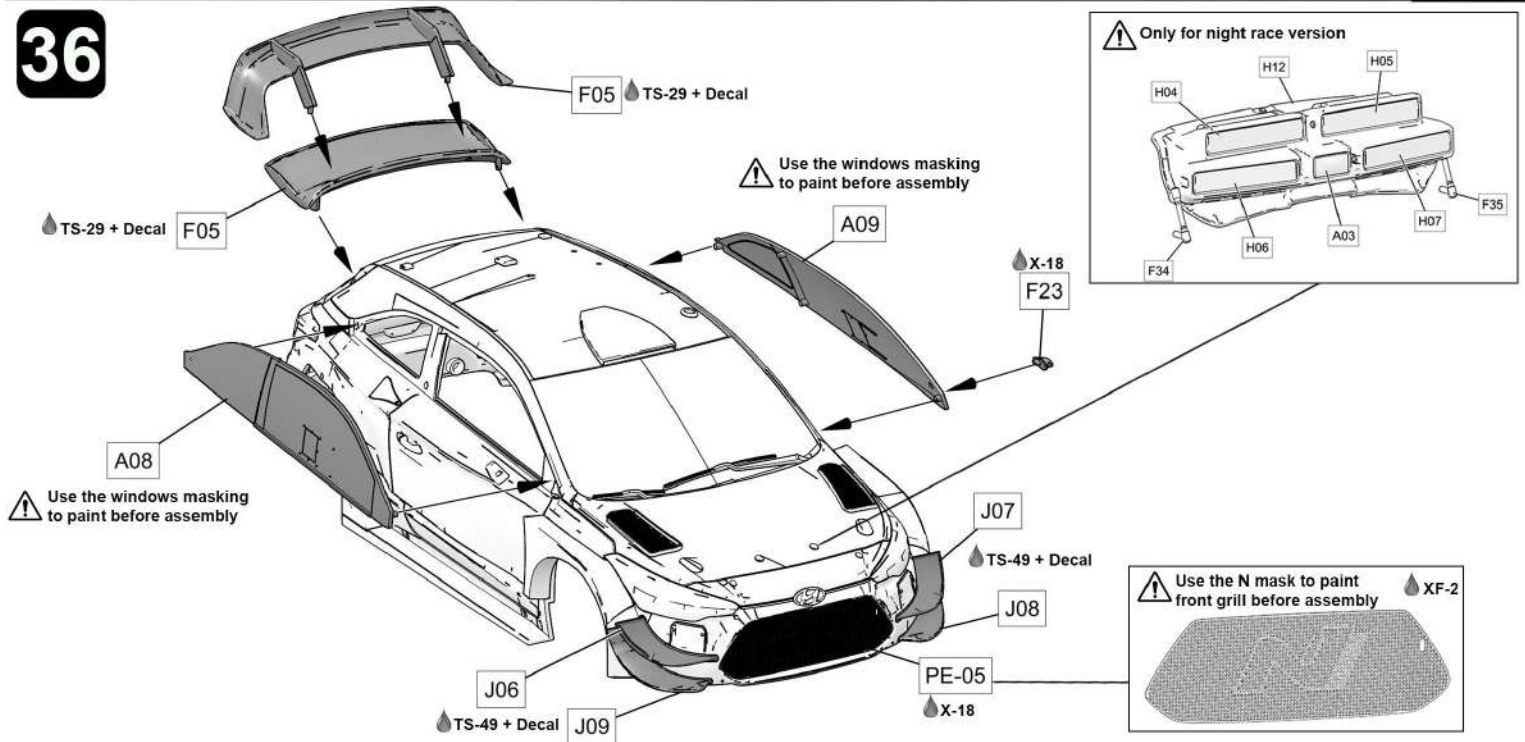

37

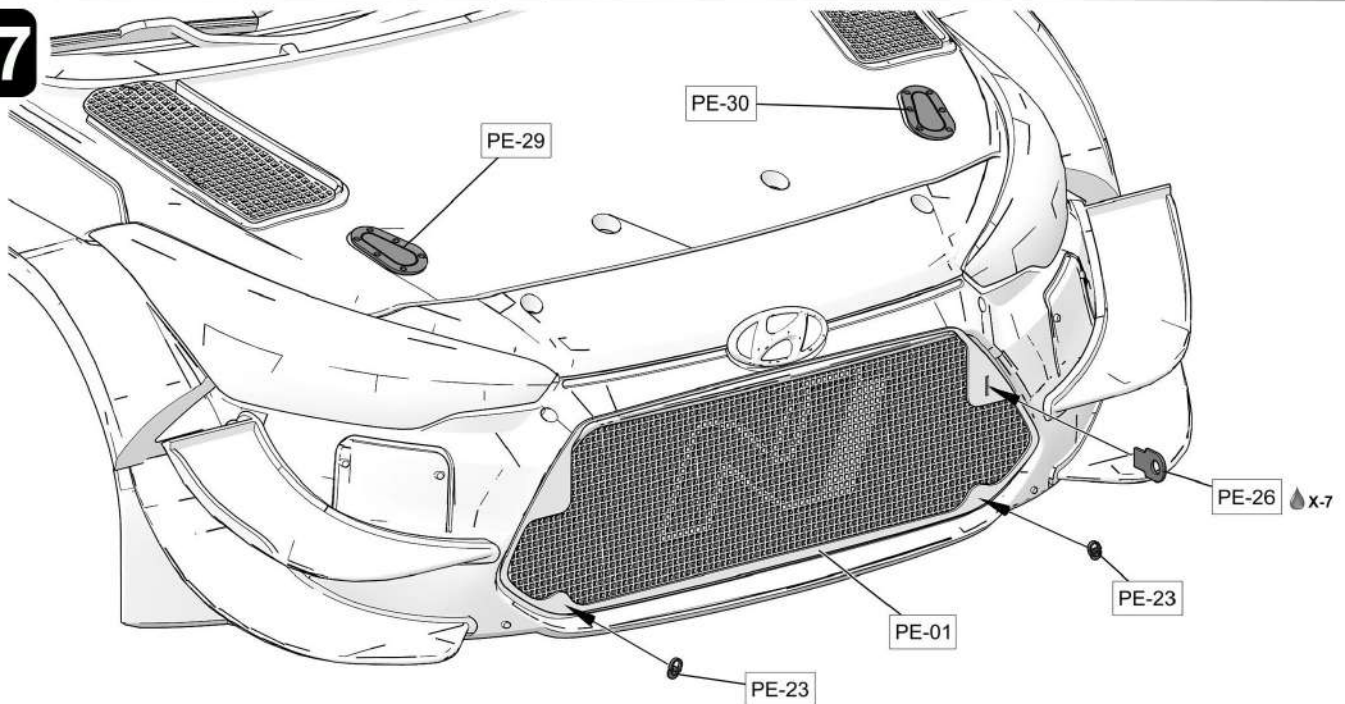

38

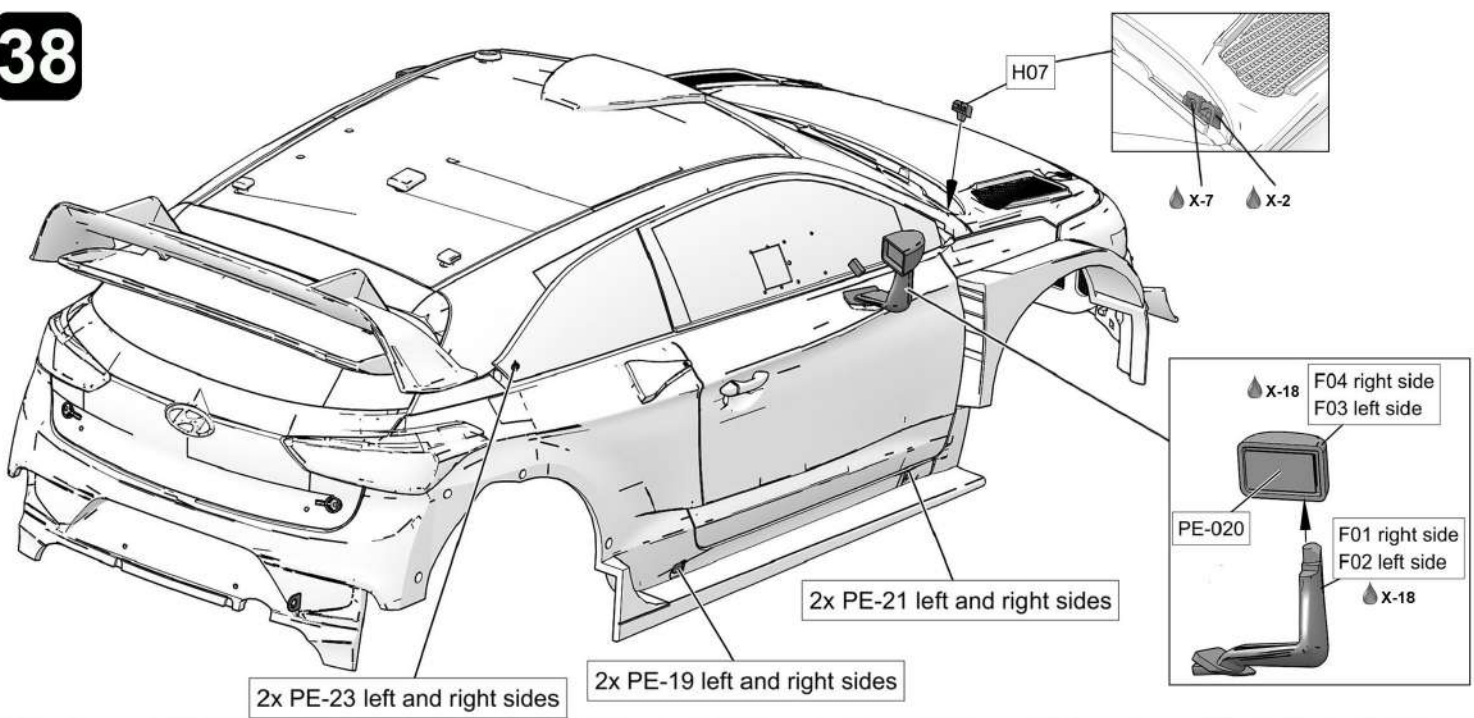

39

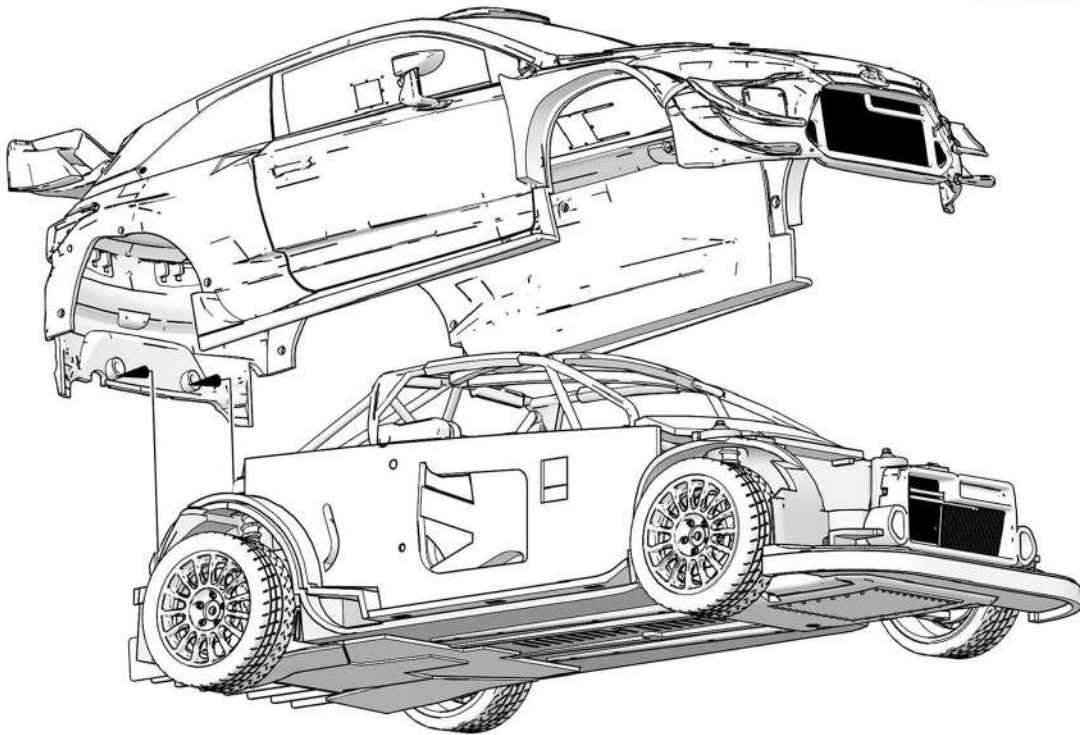

40

