

DCL-PAR096 Instructions

Place in the holes
marqued with red dots.

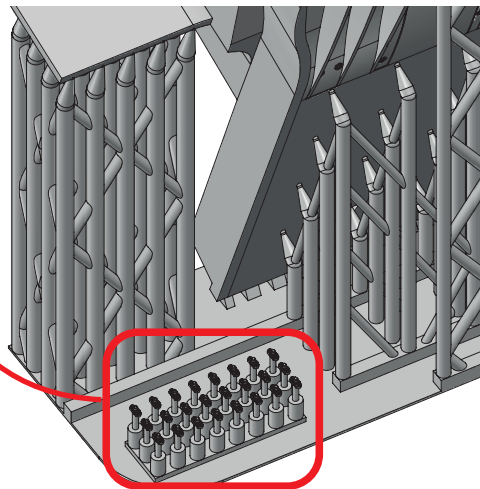
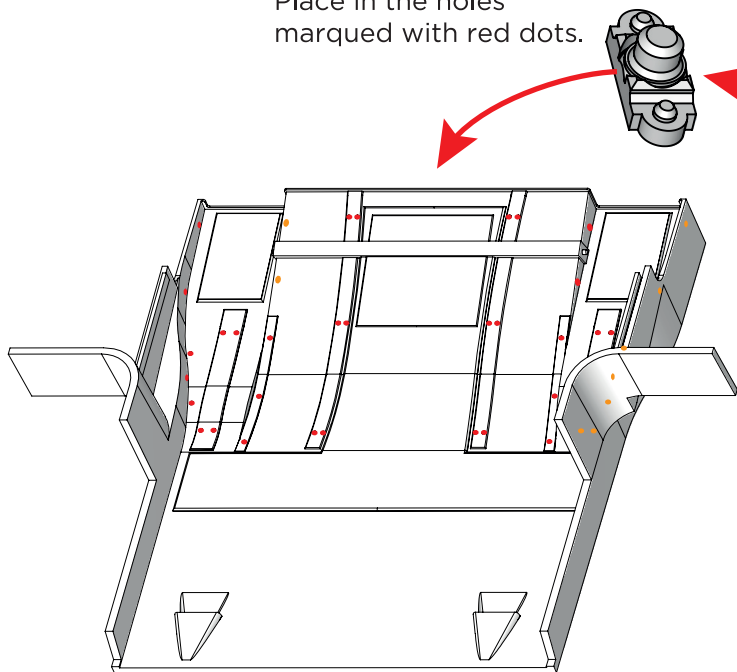

3D resin is fragile, so you should NOT use excessive force when removing the supports or joining the pieces or you risk breaking the parts.

Carry out a test assembly before painting the parts, sanding where necessary and preferably the plastic parts of the kit, until the parts fit together with light pressure without being forced.

decalcas

DCL-PAR096

Instructions

Remove the supports by cutting the contact area with the part with a scalpel, starting with those marked in red, in second place green and then blue.

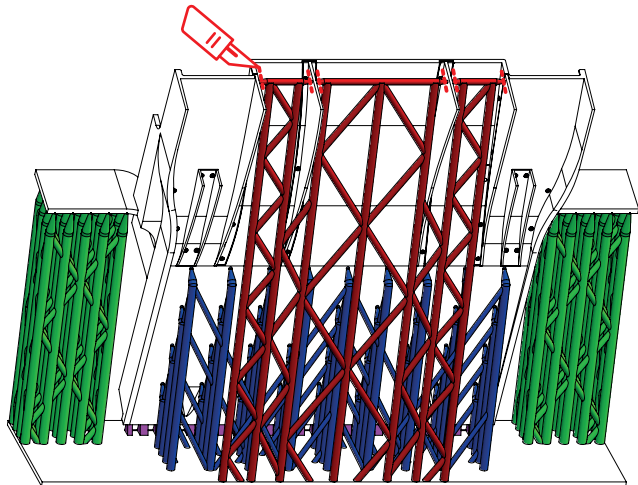

Finally remove the base cutting the supports marked in pink.

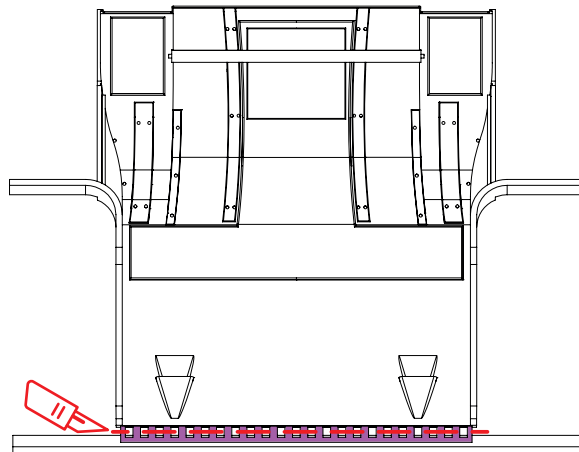

Remove the supports by cutting the contact area with the part with a scalpel, starting with those marked in red, in second place green and then blue.

