

Heller

RENAULT R8 GORDINI

80700



Français

La Régie Renault lance en 1962 la Renault 8 qui sera, avec la R10, la dernière voiture avec un moteur placé à l'arrière jusqu'à l'apparition de la Twingo III en 2014. Il faudra attendre le salon de Paris 1964 pour découvrir le modèle R8 Gordini (TYPE R1134). Elle sera très vite reconnaissable dans sa robe Bleu France 418 et sa double bande blanche courant sur toute la longueur de la voiture. Première voiture offrant des performances sportives accessible avec un budget de voiture de série, son comportement survireur (elle dérive de l'arrière) dû au moteur placé en porte à faux arrière en fera une référence de conduite sportive pour les pilotes expérimentés mais aussi pour tous les amateurs de dérapage. 981 pour la seule version 1300. Véritable icône d'une génération la Gorde s'arrache aujourd'hui à des prix de grandes sportives truffées de technologies. Ses performances restent cependant intactes.

MOTEUR

Type	4 cylindres en ligne, 8 soupapes, 1 arbre à cames latéral
Position	Transversal porte-à-faux AR
Alimentation	carburateur double corps horizontaux Solex C40 PHH

TRANSMISSION, Arrière

Boîte de vitesses	Manuelle 4/5 rapports
--------------------------	-----------------------

POIDS

Données constructeur	795 kg
-----------------------------	--------

Rapport poids/puissance en kg/ch SAE	8,36
---	------

DIMENSIONS

Longueurs en kg/ch SAE	3990 mm
-------------------------------	---------

Largeur	1490 mm
----------------	---------

Hauteur	1400mm
----------------	--------

ROUES

Freins AV & AR	disques 260 x 40 mm
---------------------------	---------------------

Pneus AV et AR	1 365 x 380
-----------------------	-------------

Deutsch

1962 brachte Renault den Renault 8 auf den Markt, der bis zum Erscheinen des Twingo III im Jahr 2014, zusammen mit dem R10 das letzte Auto mit Heckmotor war. Vorgestellt wurde der R8 Gordini (Typ R1134) erst auf dem Pariser Autosalon 1964. Schon bald erkannte man ihn an seiner blauen Lackierung in „Bleu France 418“ und den durchgehenden weißen Doppelstreifen über die gesamte Länge des Fahrzeugs. Es war das erste Auto mit sportlicher Leistung zum erschwinglichen Preis eines Serienwagens. Sein Übersteuerungsverhalten (es bricht hinten aus) aufgrund des Motors mit Hecküberhang, machte den Gordini zu einer Besonderheit für sportliches Fahren, für erfahrene Fahrer aber auch für Amateure. Insgesamt wurden 11.607 Renault Gordini produziert, davon allein 8.981 in der 1300er Version. Als wahre Ikone einer Generation muss man für den "Gorde" heute so viel bezahlen, wie für einen Sportwagen voller Technik.

MOTOR

Typ	4 Zylinder in Reihe, 8 Ventile, 1 seitliche Nockenwelle
Lage	Quer mit Hecküberhang
Gemischbildung	horizontaler Doppelvergaser Solex C40 PHH.

ANTRIEB , Heck

Boîte de vitesses	<i>4/5-Gang-Schaltgetriebe</i>
--------------------------	--------------------------------

GEWICHT

Herstellerangaben	795 kg
--------------------------	--------

Gewichts-/ Leistungsverhältnis in kg/PS SAE	8,36
--	------

ABMESSUNGEN

Länge	3990 mm
--------------	---------

Breite	1490 mm
---------------	---------

Höhe	1400mm
-------------	--------

RÄDER

Bremsen vorne und hinten	260 x 40 mm Scheiben
---------------------------------	----------------------

Reifen vorne und hinten	1 365 x 380
--------------------------------	-------------

English

In 1962, the Régie Renault launched the Renault 8 which, along with the R10, was the last car with an engine placed at the rear until the appearance of the Twingo III in 2014. It was not until the 1964 Paris Motor Show that the R8 Gordini (TYPE R1134) was introduced. It will very quickly be recognisable in its Bleu France 418 dress and its double white stripe running the length of the car. The first car offering sporty performance accessible with a production car budget, its oversteer behaviour (it drifts from the rear) due to the engine placed in rear overhang will make it a reference of sporty driving for experienced drivers but also for all skidding amateurs. A total of 11607 Renault Gordini were produced, including 8981 for the 1300 version alone. A true icon of a generation, the "Gorde" is today a true icon of a generation, and is now competing at the price of great sports cars full of technology. Its performance remains intact, however.

ENGINE

Type	4 in-line cylinders, 8 valves, 1 lateral camshaft
Position	transversal rear overhang
Feed	Solex C40 PHH horizontal double-barrel carburetors

TRANSMISSION, Rear-wheel drive

Gearbox	Manual 4/5 speeds
----------------	-------------------

WEIGHT

Automaker's data	795 kg
-------------------------	--------

Weight-to-power ratio in kg/SAE hp	8,36
---	------

DIMENSIONS

Length	3990 mm
---------------	---------

Width	1490 mm
--------------	---------

Height	1400mm
---------------	--------

WHEELS

Front and rear brakes	260 x 40 mm discs
------------------------------	-------------------

Front and rear tyres	1 365 x 380
-----------------------------	-------------

Español

La administración de Renault lanzó en 1962 el Renault 8, que sería, con el R10, el último automóvil con un motor colocado en la parte trasera hasta la aparición del Twingo III en 2014. Hubo que esperar al Salón de París de 1964 para descubrir el modelo R8 Gordini (TIPO R1134). En seguida se reconocería por su atuendo azul Francia 418 y su doble banda blanca a lo largo del automóvil. Como primer automóvil que ofrecía un rendimiento deportivo accesible con un presupuesto estándar para coches de serie, su comportamiento de sobre viraje (derivado de la parte trasera) debido al motor colocado en el voladizo trasero lo convertiría en una referencia de conducción deportiva no solo para los pilotos experimentados, sino también para todos los amantes del derrape. Se produjeron un total de 11.607 Renault Gordini, 8981 de los cuales correspondían a la versión 1300. Un verdadero ícono de una generación, el "Gorde" se desvincula actualmente de los precios de los grandes deportivos cargados de tecnología. No obstante, su rendimiento permanece intacto.

MOTOR

Typo	4 cilindros en línea, 8 válvulas, 1 árbol de levas lateral
Posición	transversal, voladizo trasero
Alimentación	carburador horizontal Solex C40 PHH de doble cuerpo

TRANSMISIÓN , Trasera

Caja de cambios	<i>manual, 4/5 marchas</i>
------------------------	----------------------------

PESO

Datos del fabricante	795 kg
-----------------------------	--------

Relación peso/potencia en kg/CV SAE:	8,36
---	------

DIMENSIONES

Longitud	3990 mm
-----------------	---------

Anchura	1490 mm
----------------	---------

Altura	1400mm
---------------	--------

RUEDAS

Frenos delanteros y traseros	de disco, 260 x 40 mm
-------------------------------------	-----------------------

Neumáticos delanteros y traseros	1 365 x 380
---	-------------

Italiano

Nel 1962 la Renault lancia la R8, che sarà insieme alla R10 l'ultima autovettura con motore posteriore fino alla comparsa della Twingo III nel 2014. Sarà necessario attendere il salone di Parigi del 1964 per l'arrivo del modello R8 Gordini (TYPE R1134). Diventerà molto presto riconoscibile grazie alla livrea "Blu Francia 418" e alla doppia banda bianca su tutta la lunghezza. Prima autovettura a offrire prestazioni sportive a un budget accessibile, il servofreno e il motore posizionato sullo sbalzo posteriore la renderanno un riferimento di guida sportiva non solo per i piloti esperti, ma anche per tutti gli amanti delle derivate. In totale sono state prodotte 11607 Renault Gordini, di cui 8981 solo in versione 1300. Vera icona di una generazione, la "Gorde" si avvicina oggi ai prezzi delle automobili sportive più tecnologiche. Le sue prestazioni rimangono quindi intatte.

MOTORE

Tipo	4 cilindri in linea, 8 valvole, 1 albero a camme laterale
Posizione	trasversale sullo sbalzo posteriore
Alimentazione	carburatore doppio corpo orizzontale Solex C40 PHH

MOTORE, Posteriore

Cambio	manuale 4/5 marce
---------------	-------------------

PESO

Dati del costruttore	795 kg
-----------------------------	--------

Rapporto peso/potenza in kg/CV SAE:	8,36
--	------

DIMENSIONI

Lunghezza	3990 mm
------------------	---------

Larghezza	1490 mm
------------------	---------

Altezza	1400mm
----------------	--------

RUOTE

Freni anteriori e posteriori	dischi 260 x 40 mm
-------------------------------------	--------------------

Pneumatici anteriori e posteriori	1 365 x 380
--	-------------

Nederlands

Het staatsbedrijf Renault bracht in 1962 de Renault 8 op de markt, die samen met de R10, de laatste auto met een motor achteraan zou zijn tot de verschijning van de Twingo III in 2014. Men diende te wachten tot het salon van Parijs in 1964 om kennis te maken met het model R8 Gordini (TYPE R1134). De auto werd al snel herkenbaar met zijn "Blue France 418" blauwe kleur en zijn dubbele witte strook over de volledige lengte. De eerste auto die sportprestaties levert met het prijskaartje van een serie geproduceerd voertuig. Zijn oversturend rijgedrag (slipt aan de achterkant), door de motor die in de achterovergaan is geplaatst, zorgde voor een sportief rijden voor zowel ervaren piloten als alle bestuurders die eens graag slippen. Er werden in totaal 11607 Renault Gordini gemaakt, waarvan 8981 voor alleen de versie 1300. De "Gorde", een echt icoon van een generatie, wordt vandaag de dag verkocht aan een prijs die u voor een luxe sportauto vol technologie zou betalen. Zijn prestaties blijven echter intact.

MOTOR

Type	4 cilinders in lijn, 8 kleppen, 1 laterale nokkenas
Positie	transversale achteroverhang
Voeding	Solex C40 PHH horizontale carburator met dubbele behuizing

OVERBRENGING, Achterwielaandrijving

Versnellingsbak	Handmatig 4/5 versnellingen
------------------------	-----------------------------

GEWICHT

Gegevens van fabrikant	795 kg
-------------------------------	--------

Verhouding tussen gewicht en vermogen in kg/SAE PK gewicht en vermogen in kg/SAE PK:	8,36
---	------

AFMETINGEN

Lengte	3990 mm
---------------	---------

Breedte	1490 mm
----------------	---------

Hoogte	1400mm
---------------	--------

WIELEN

Voor- en achterremmen	260 x 40 mm schijven
------------------------------	----------------------

Voor- en achterbanden	1 365 x 380
------------------------------	-------------

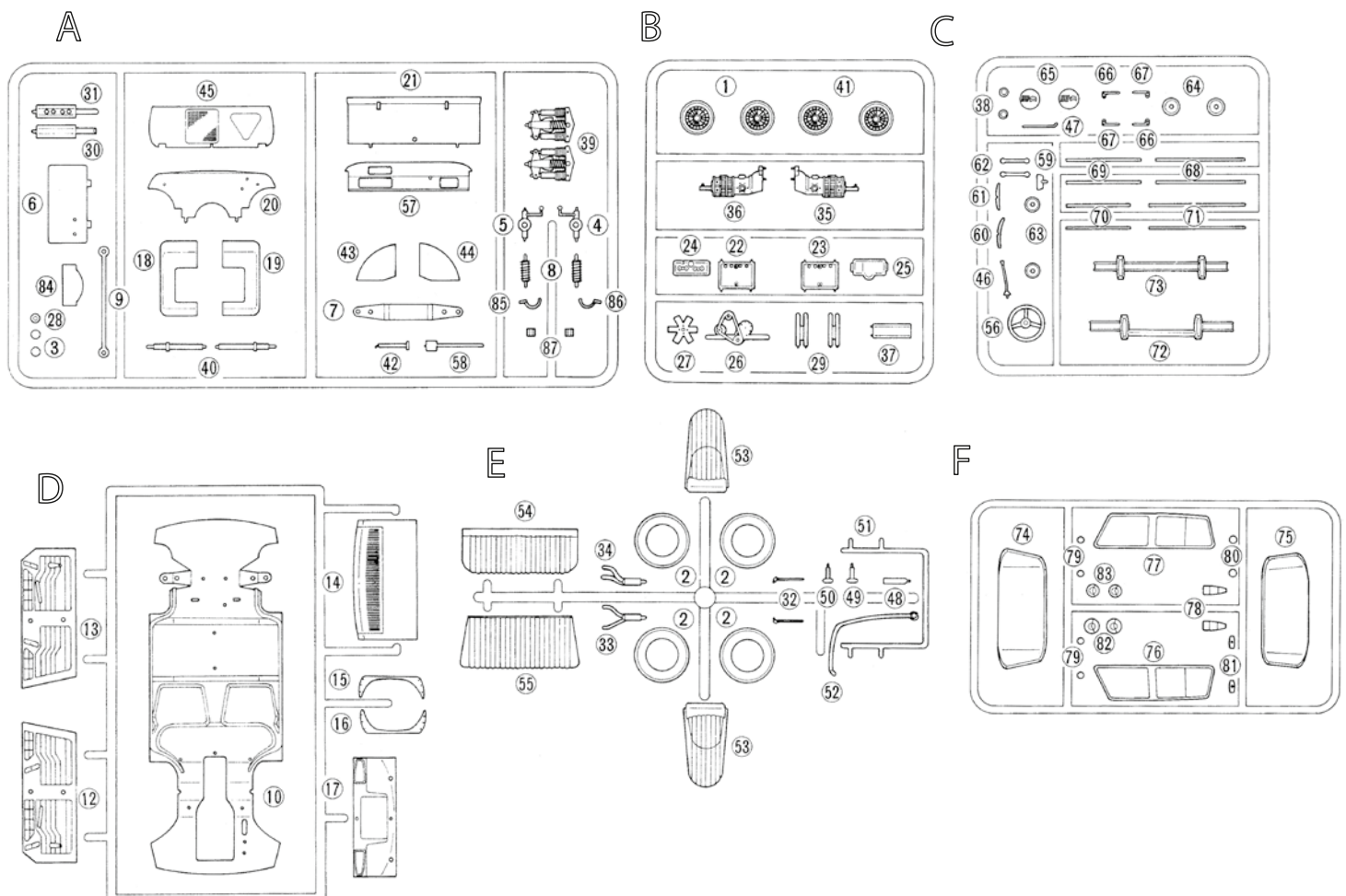

PEINTURES ESSENTIELLES / ESSENTIAL PAINTS



11
Argent
Silver
Silber



14
Bleu brillant
Gloss blue
Glänzend-Blau



64
Gris clair mat
Matt light grey
Matt-Hellgrau



85
Noir satiné
Satin black
Seidenmatt-Schwarz



321
Rouge transparent
Clear red
Durchsichtiges Rot



322
Orange transparent
Clear orange
Durchsichtiges Orange

PEINTURES COMPLEMENTAIRES / ADDITIONAL PAINTS

Disponibles séparément chez votre revendeur de maquettes. /

Available separately at you local hobby shop.



30
Vert foncé mat
Matt dark green
Matt-Dunkelgrün



33
Noir mat
Matt black
Matt-Schwarz



56
Aluminium
Aluminium
Aluminium



69
Jaune brillant
Gloss yellow
Glänzend-Gelb



92
Gris fer mat
Matt iron grey
Matt-Eisengrau



101
Vert moyen mat
Matt mid green
Matt-Mittelgrün



130
Blanc satiné
Satin white
Satin Weiss

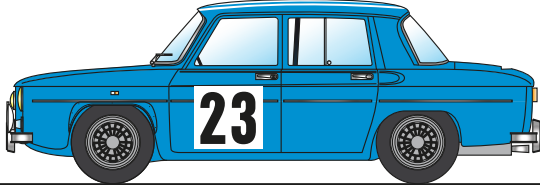

• N° 23 – 7ème - Jean-François PIOT/Michel KARAKY - Rallye Monte Carlo 1967



• N° 41 – 7ème - Jean-Pierre NICOLAS / Claude ROURE – Tour de Corse 1967

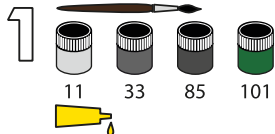

33
B27

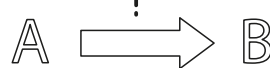
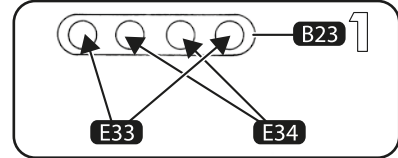
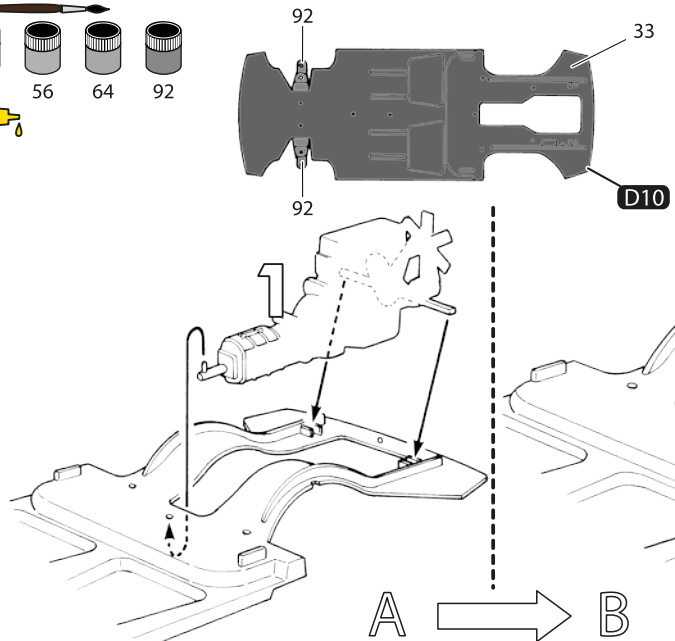
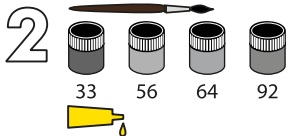
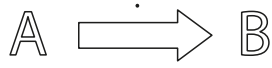
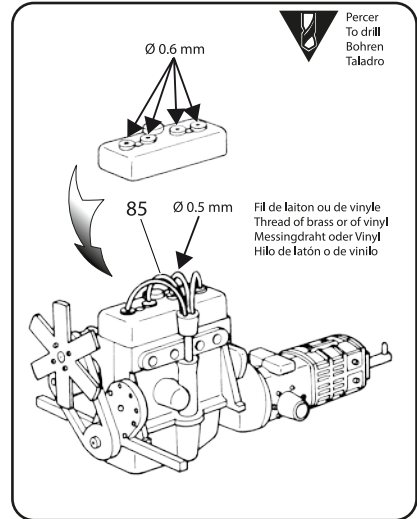
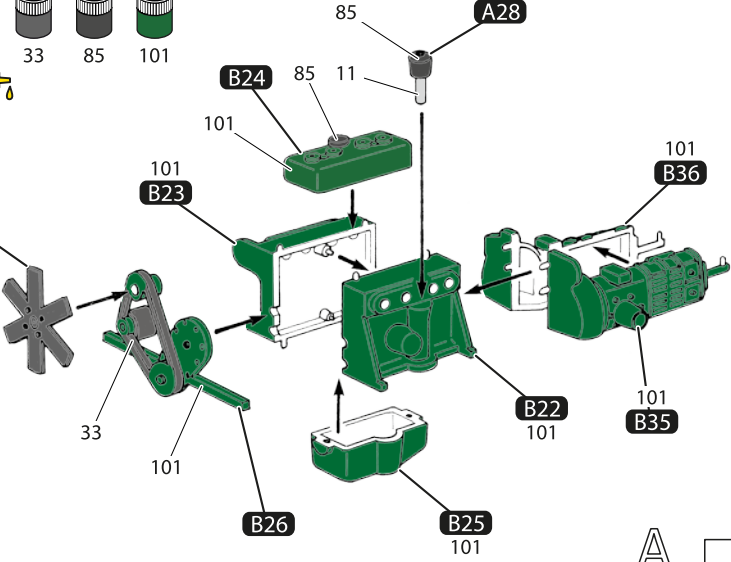

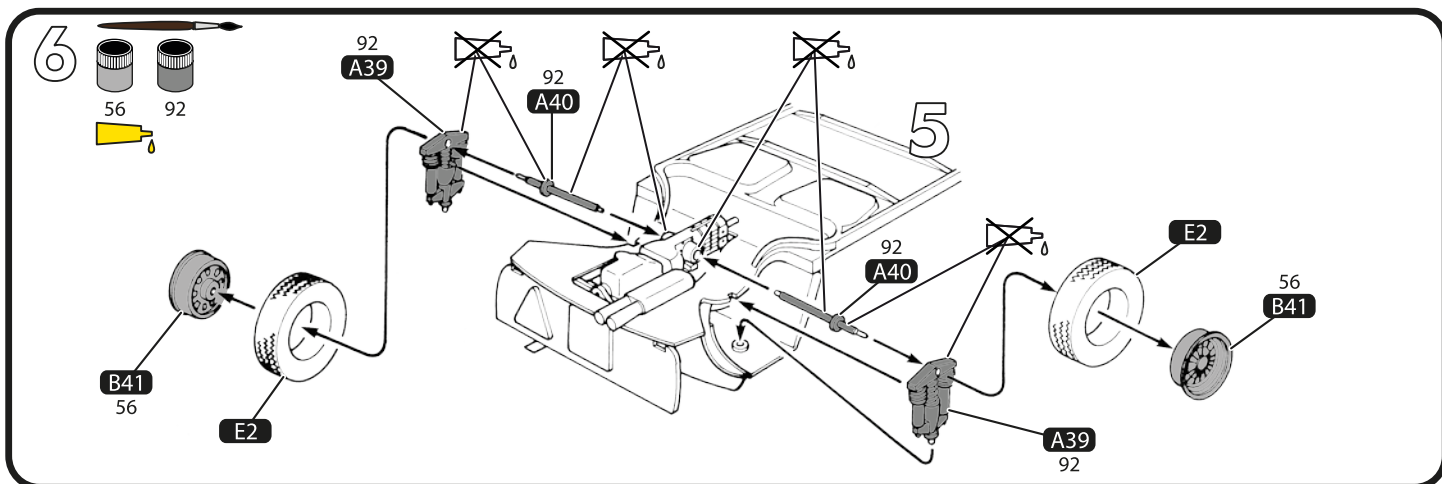
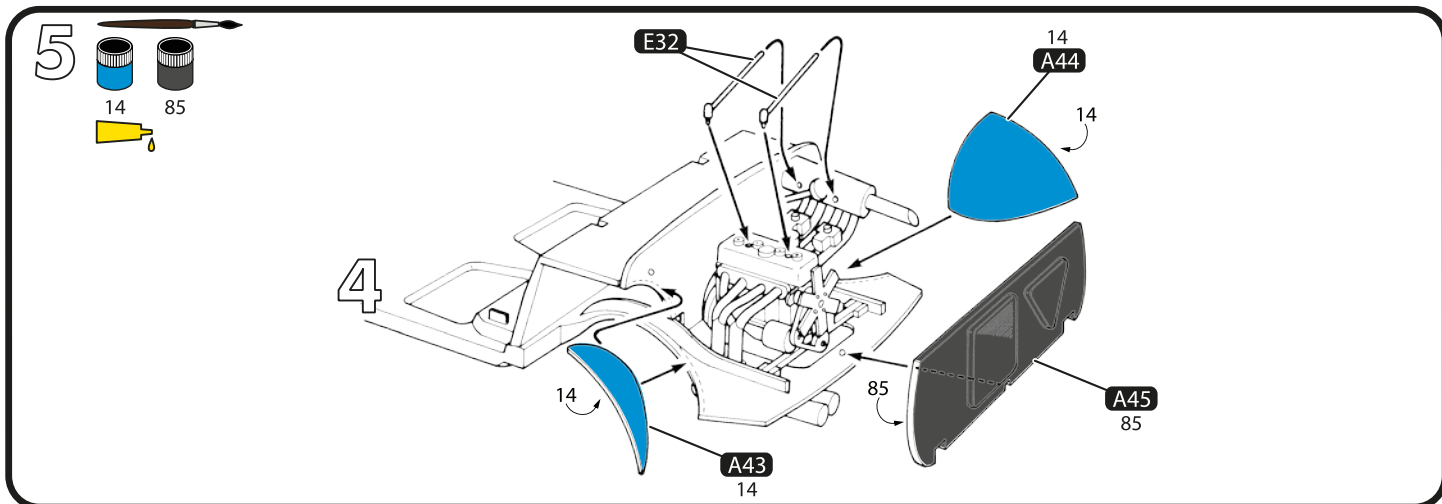
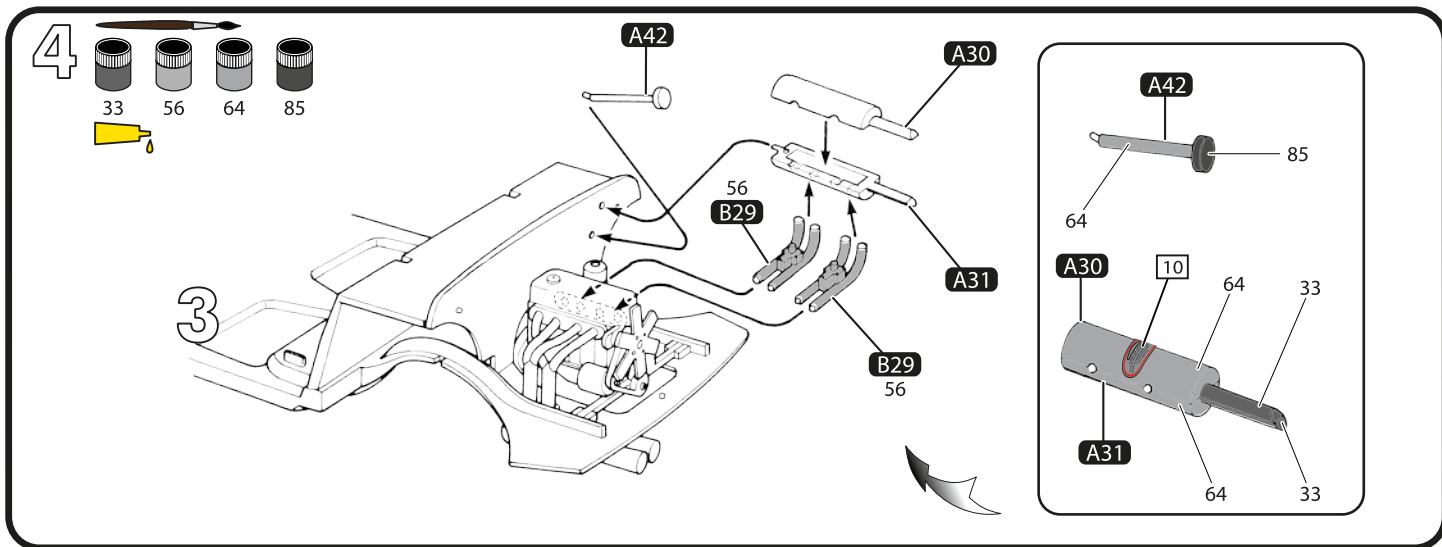
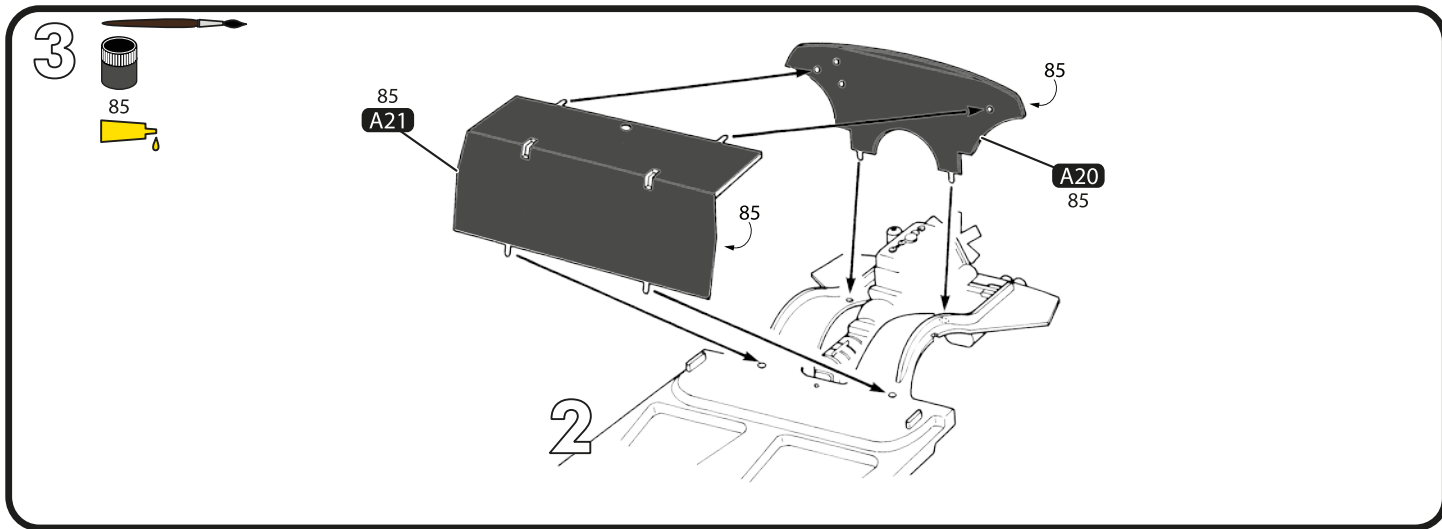

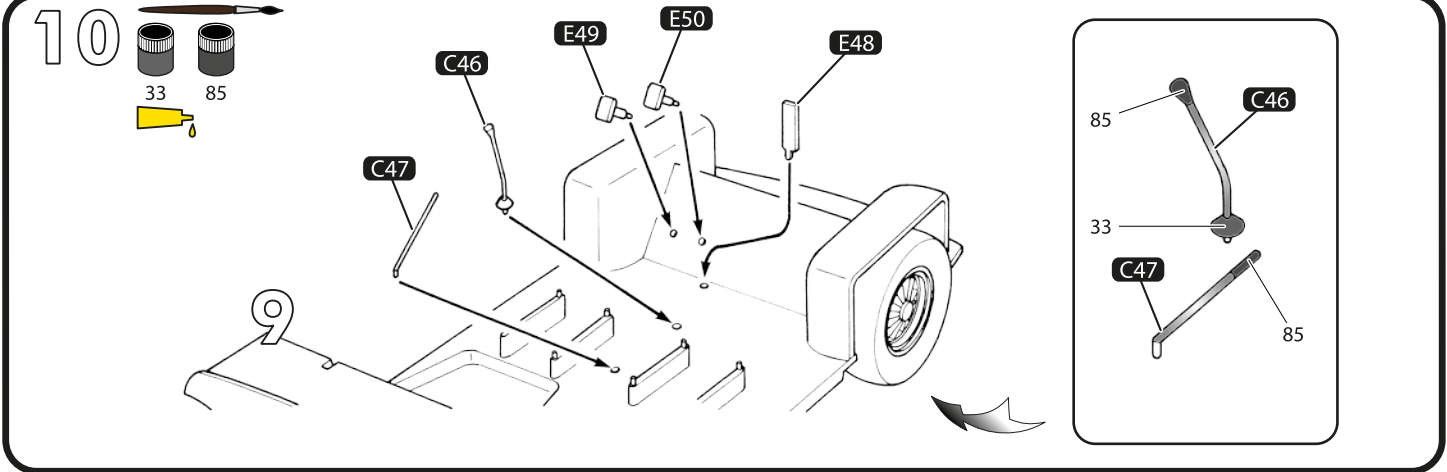
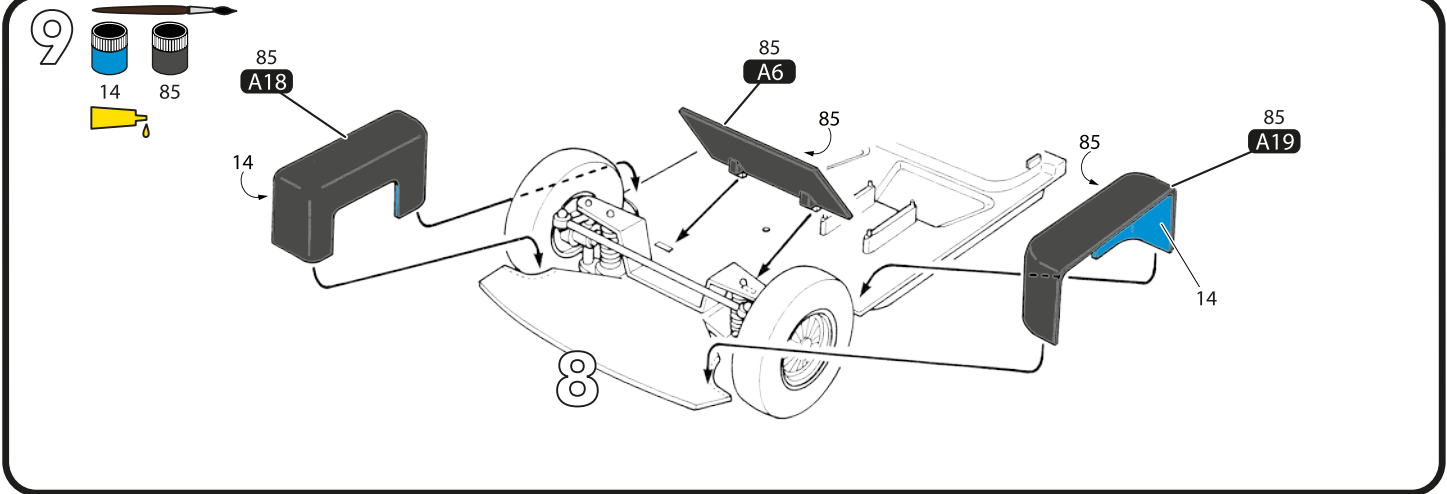
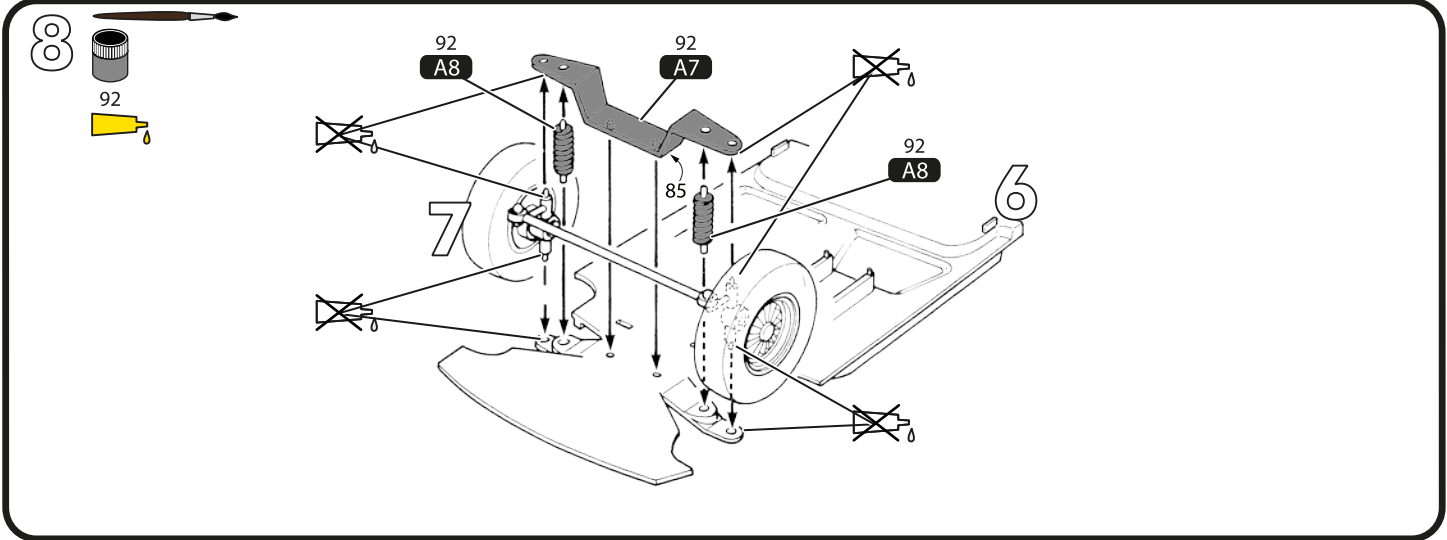
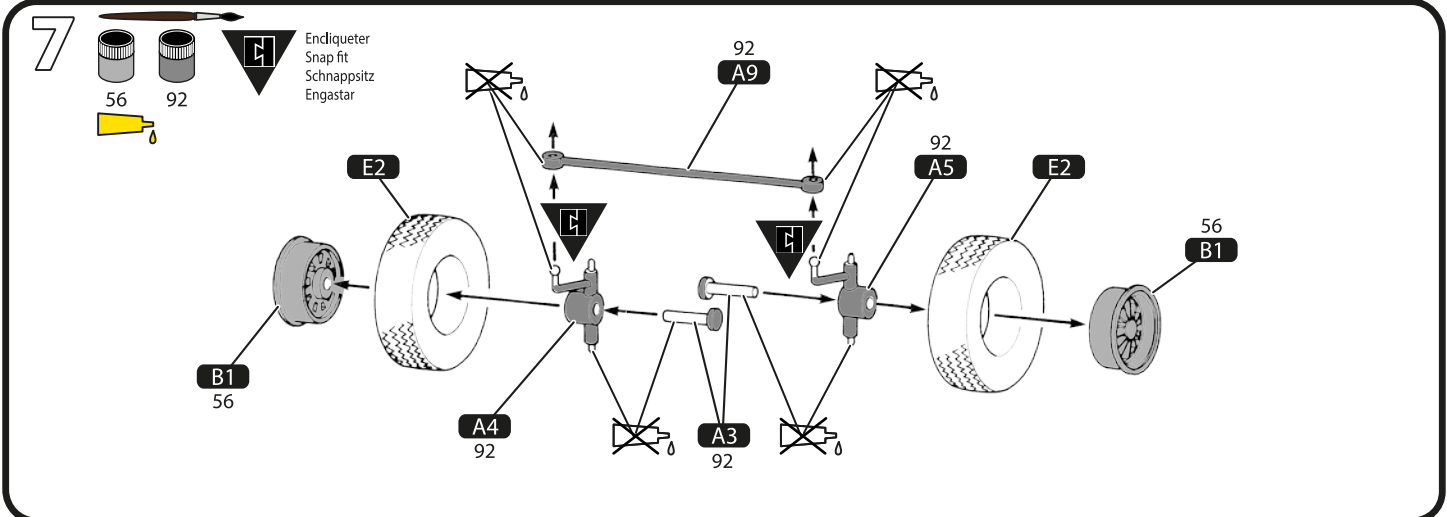

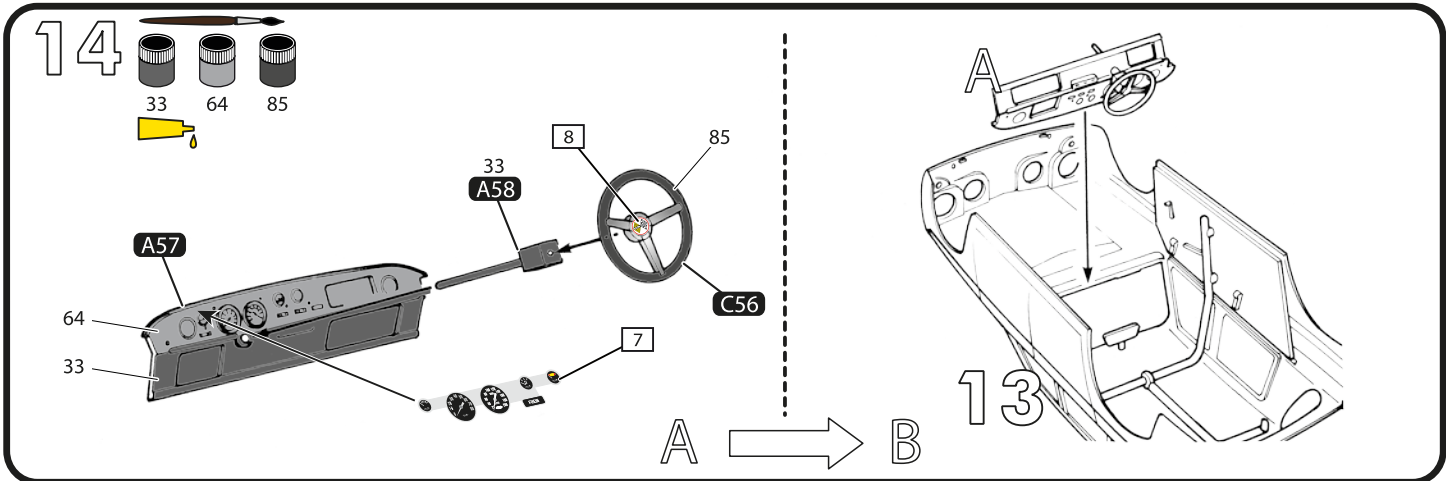
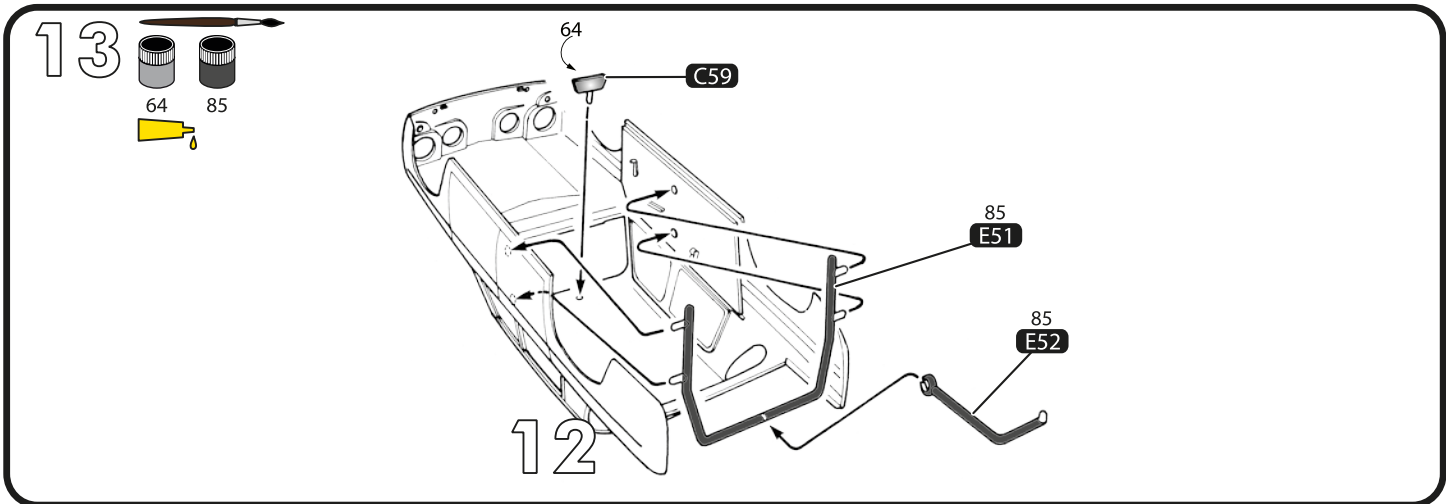
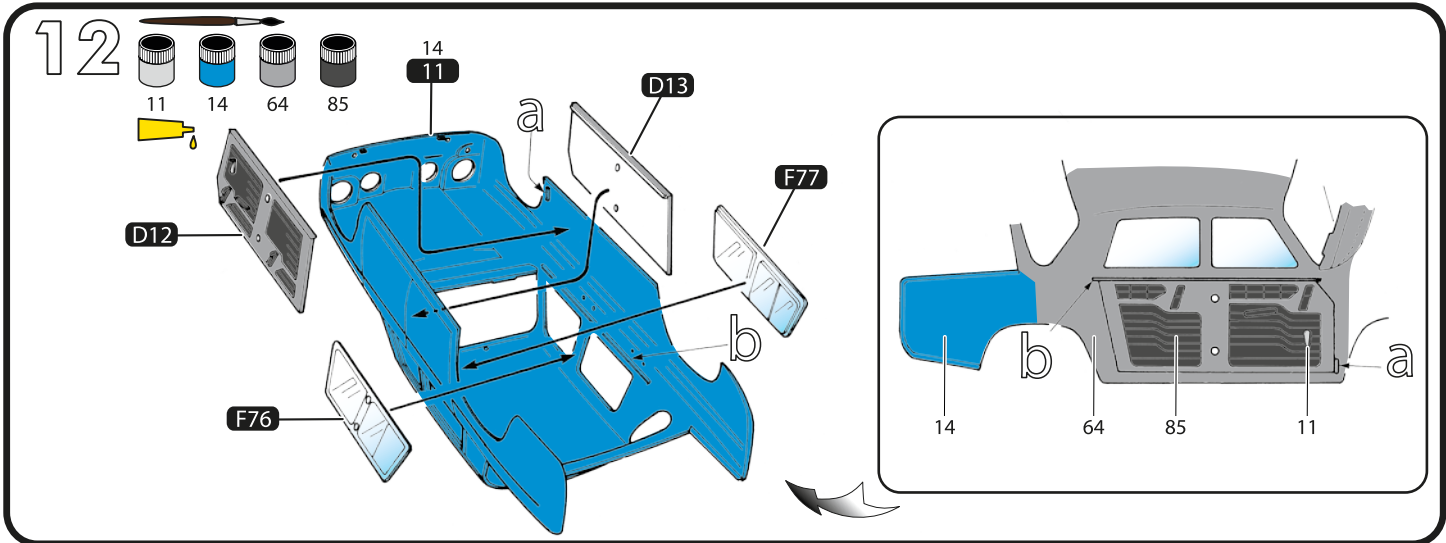
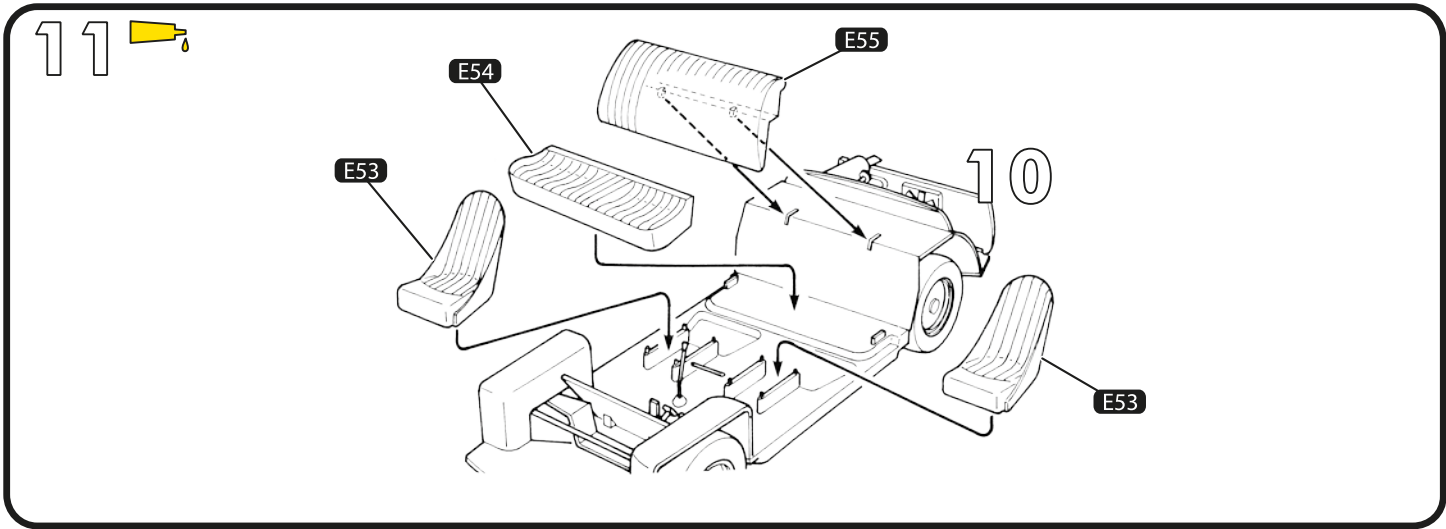

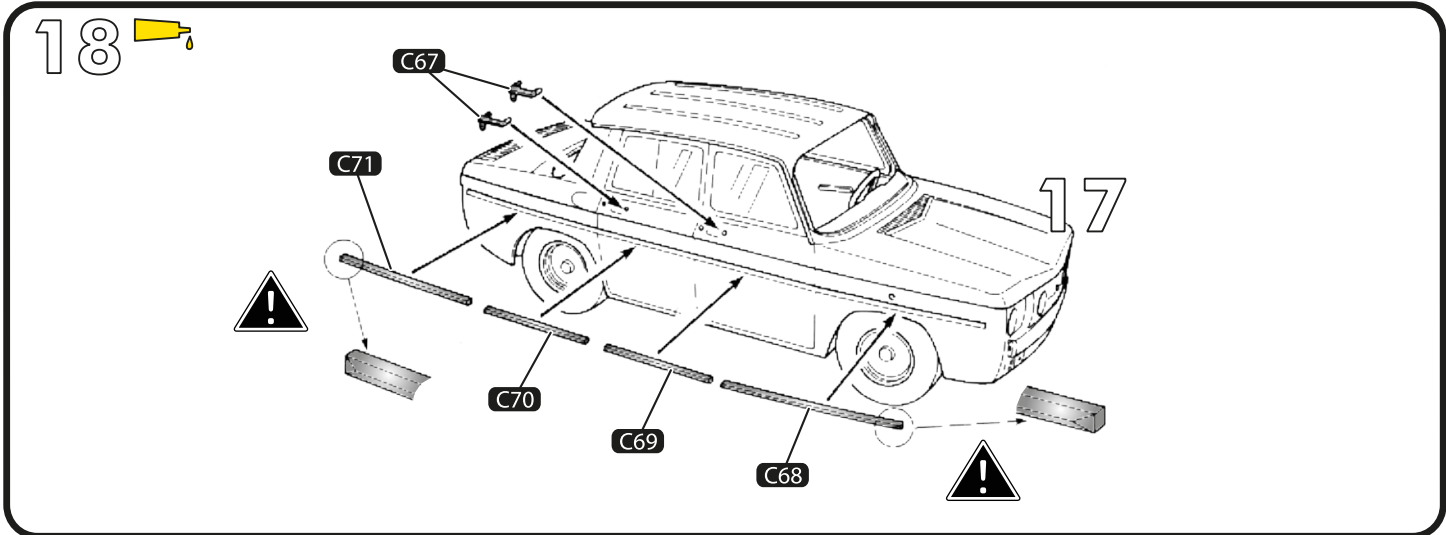
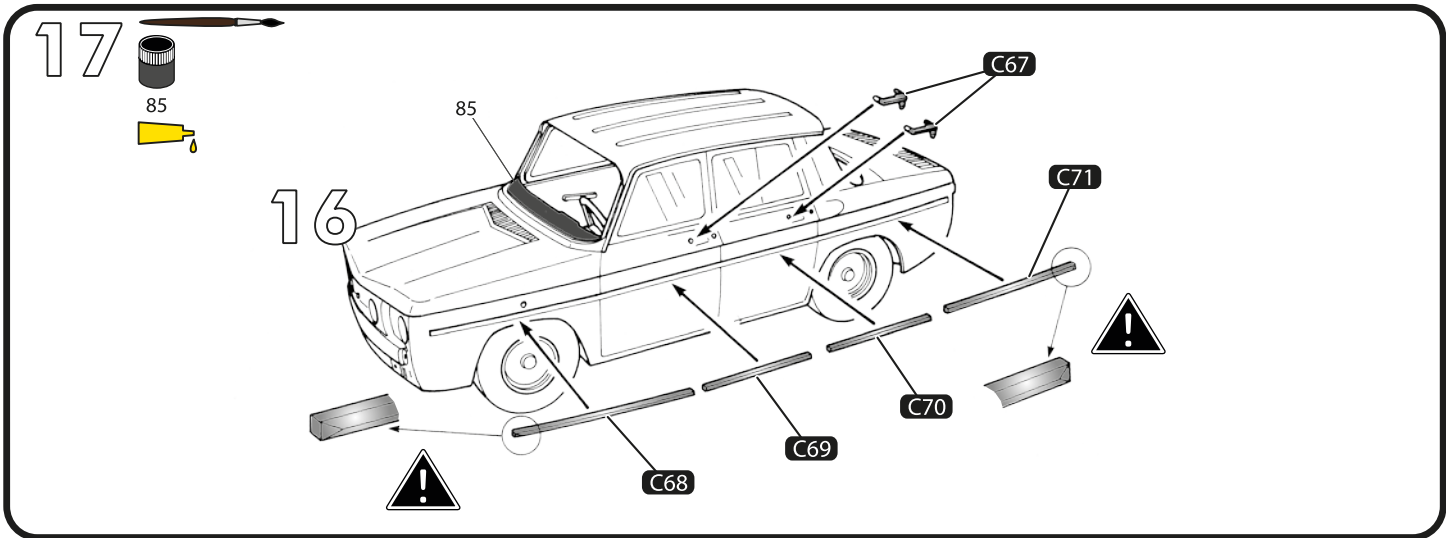
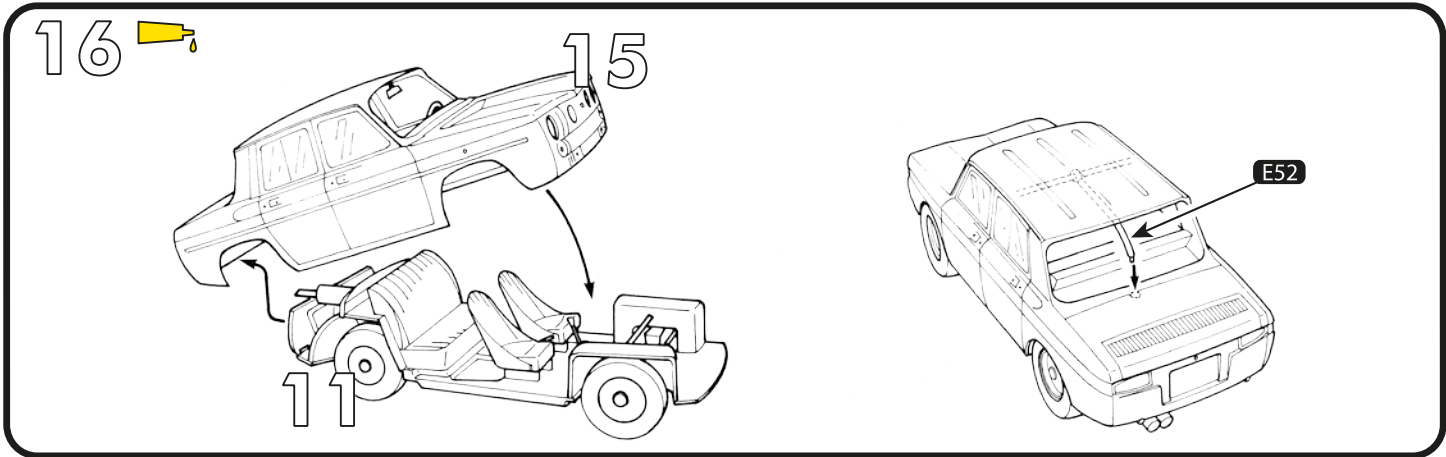
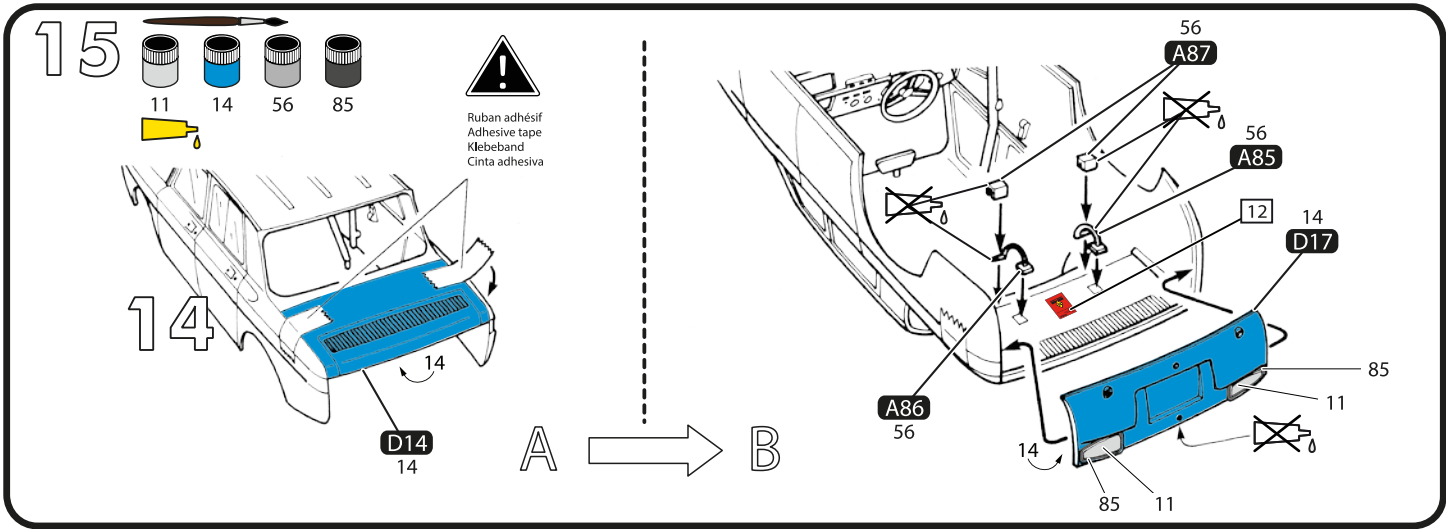

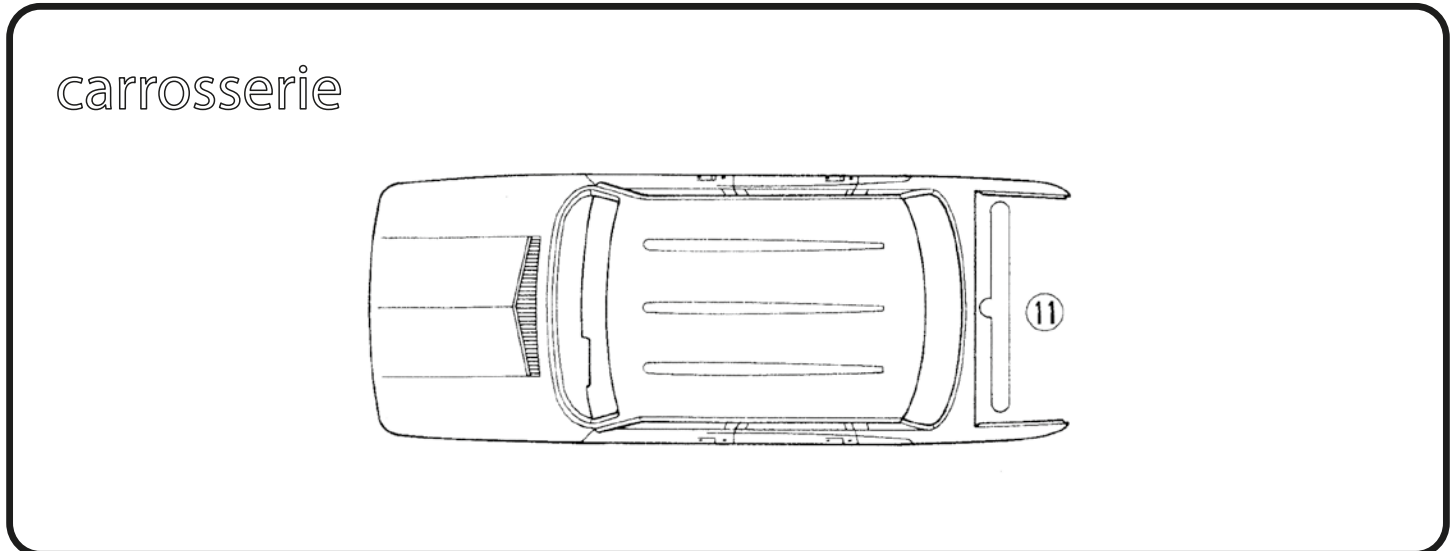
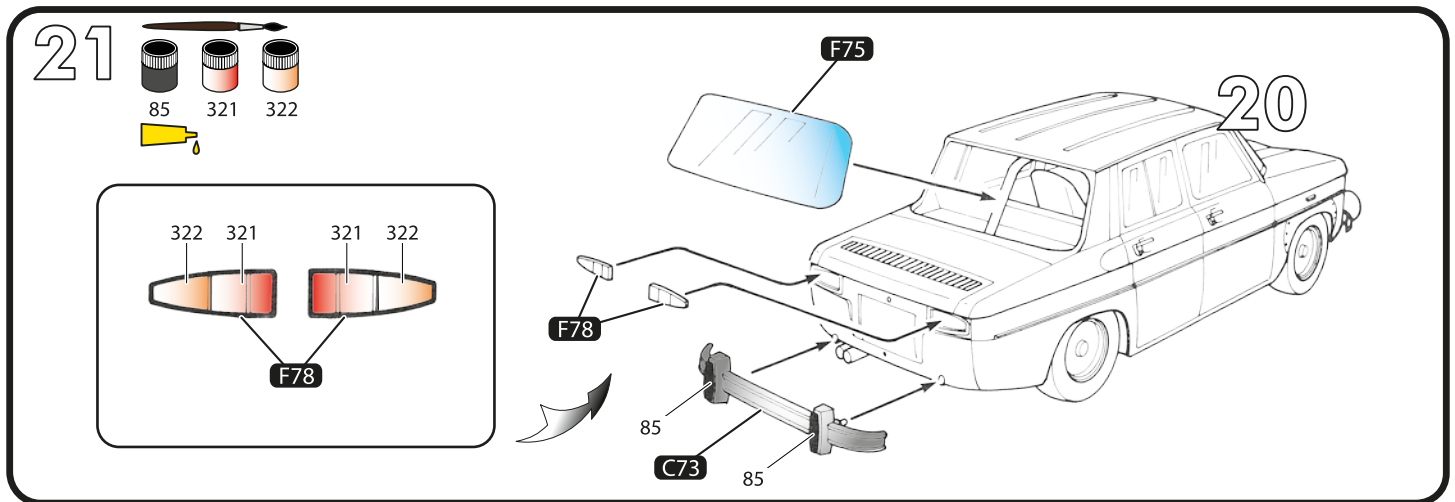
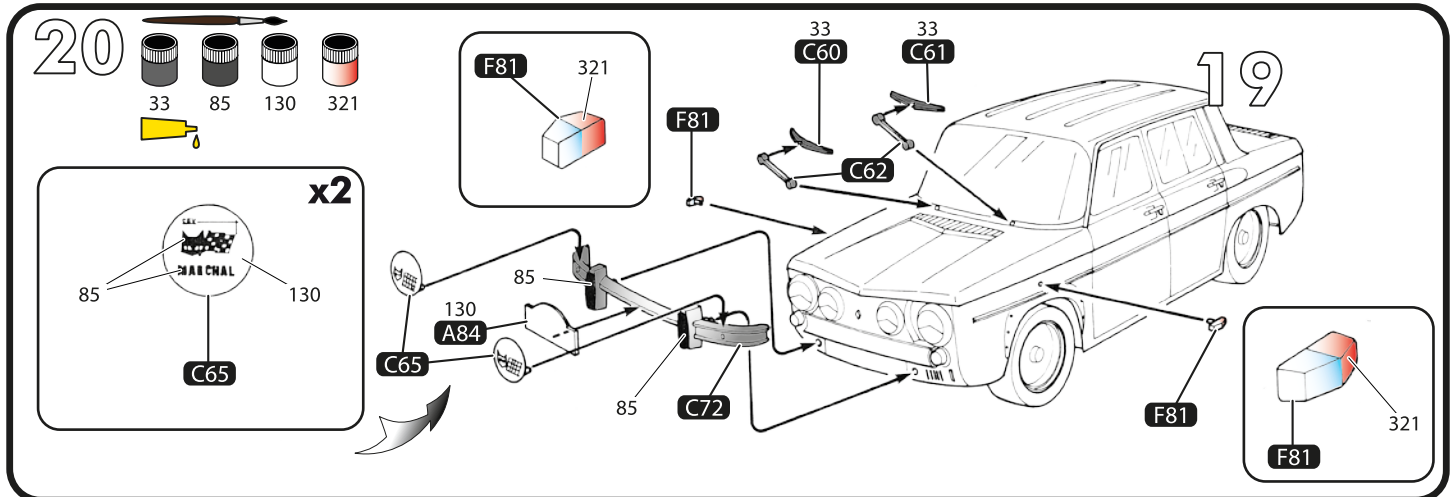
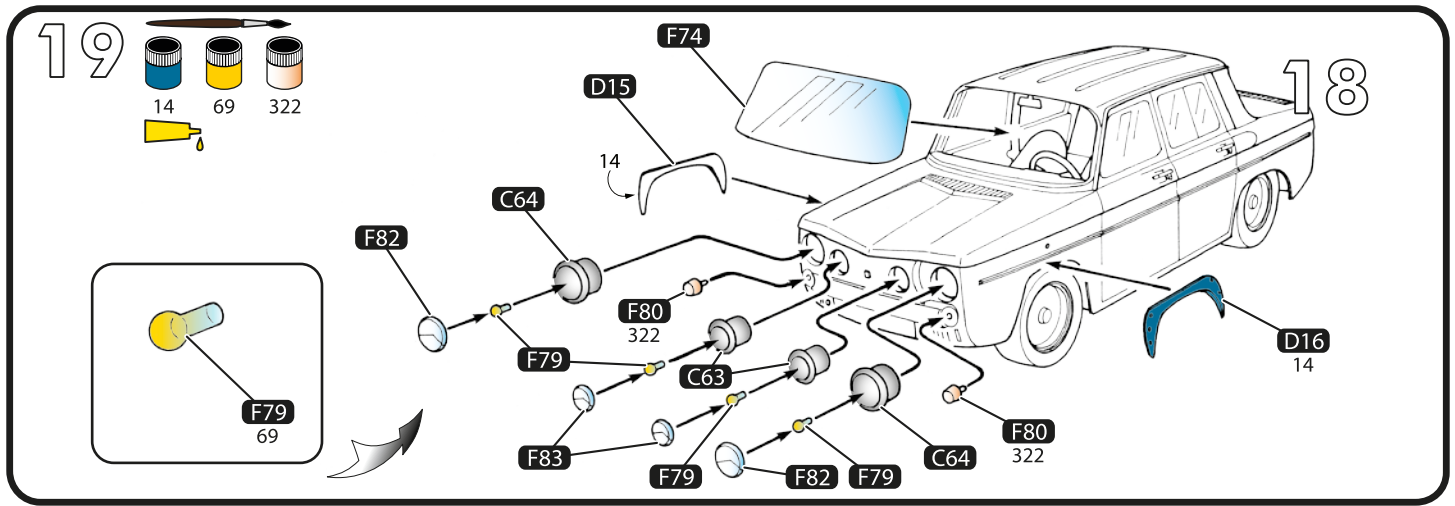

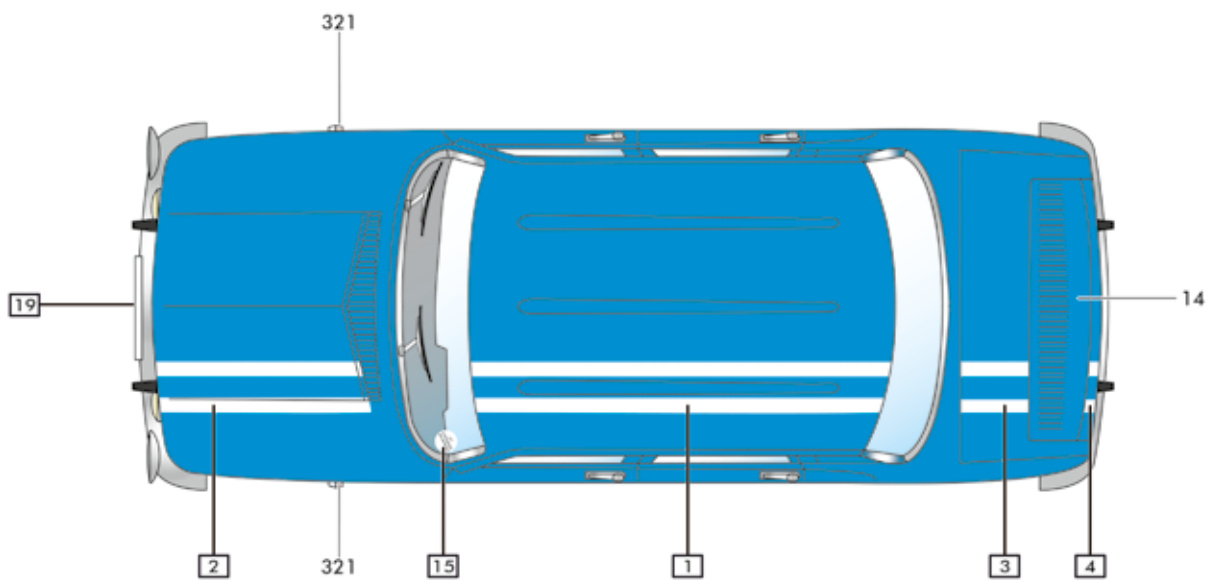
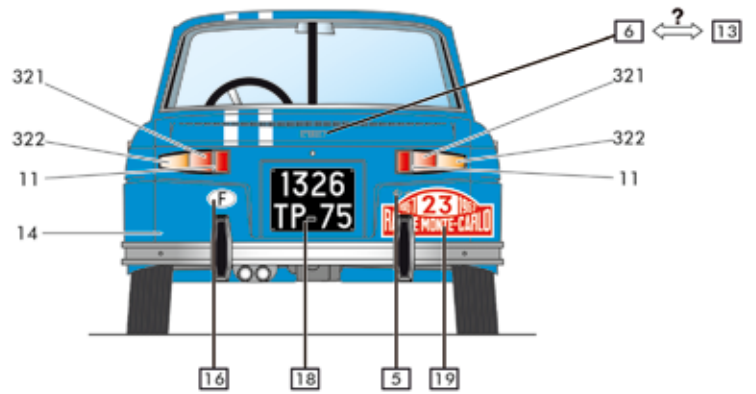
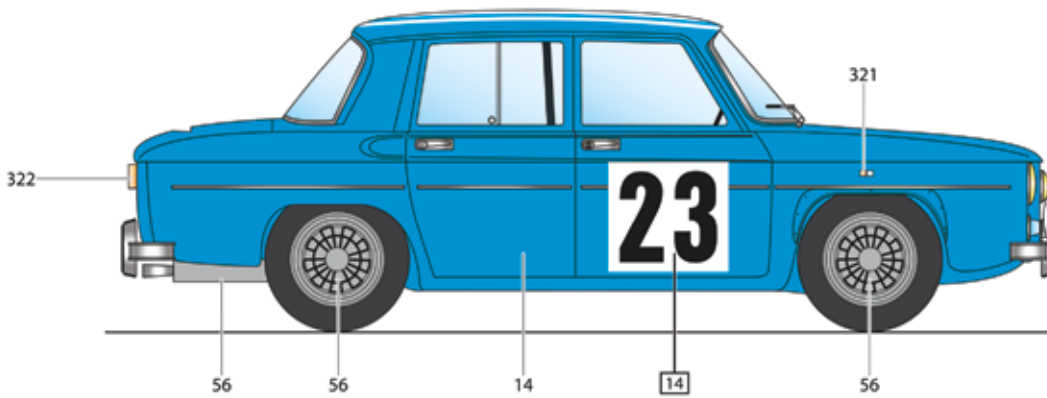
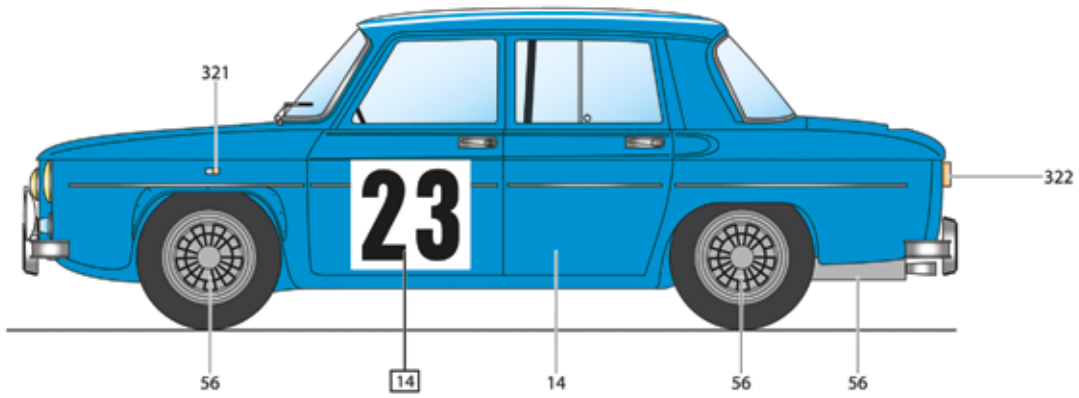

22



N° 41 - 7ème - Jean-Pierre NICOLAS / Claude ROURE - Tour de Corse 1967

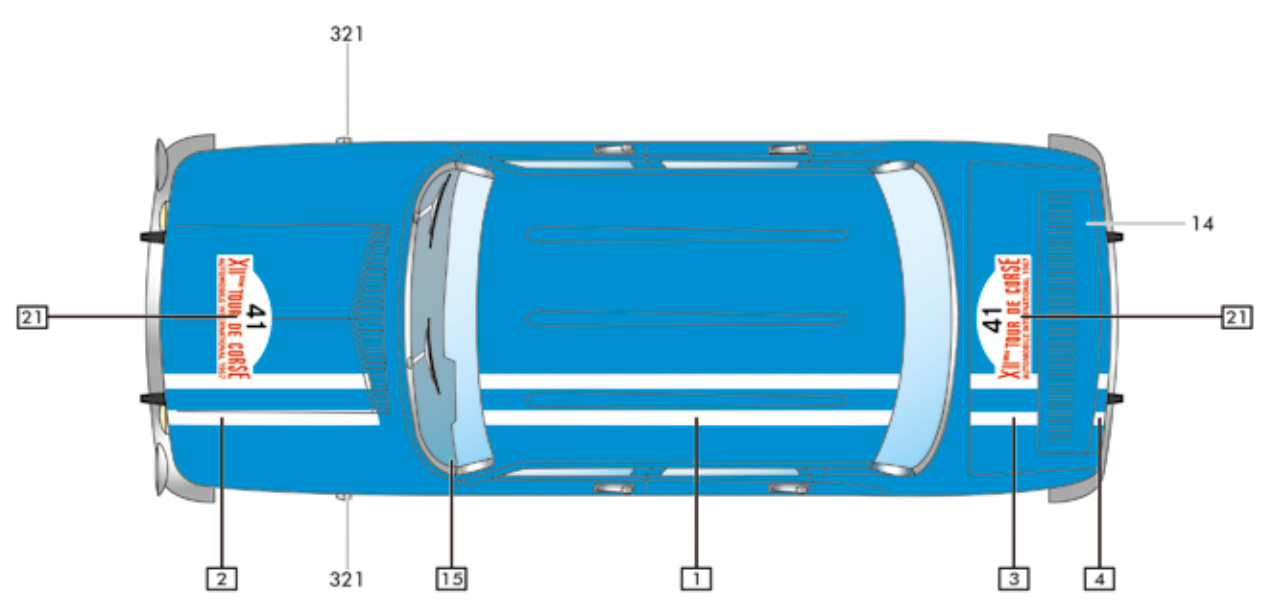
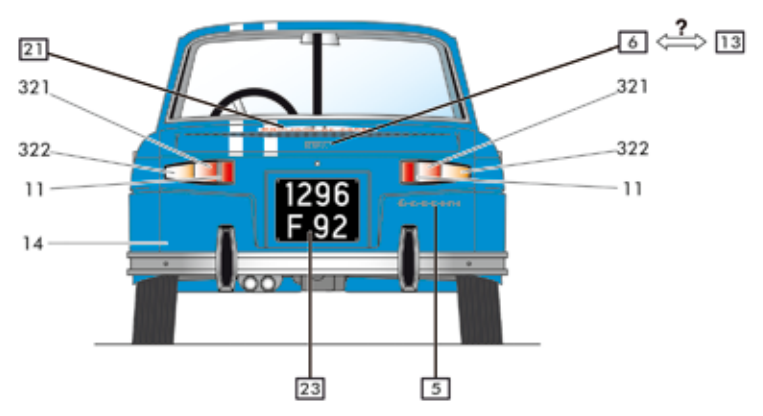
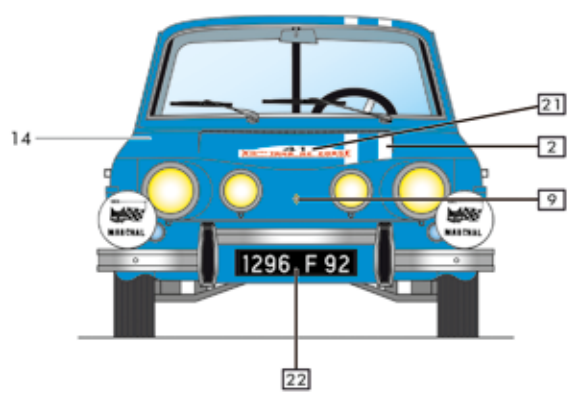
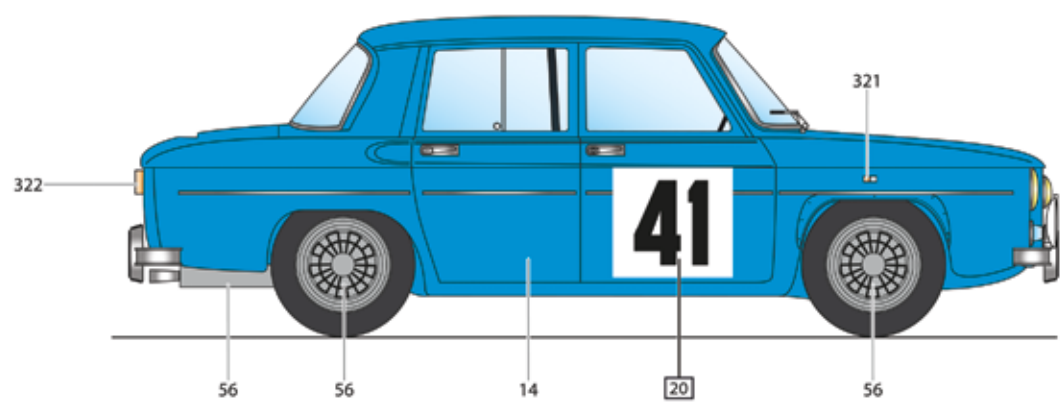
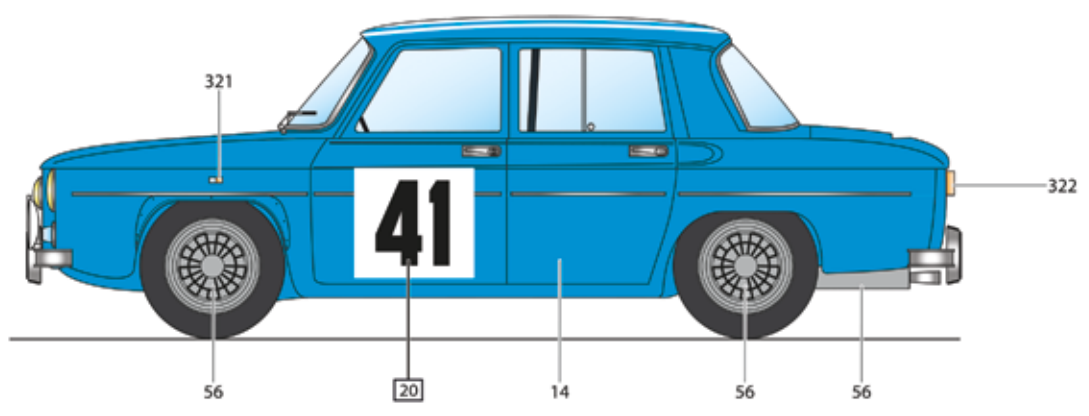

VISITEZ-NOUS EN LIGNE !

VISIT US DIGITALLY!
BESUCHEN SIE UNS DIGITAL!

 www.heller.fr

 [instagram.com/heller.fr](https://www.instagram.com/heller.fr)

 [facebook.com/heller.fr](https://www.facebook.com/heller.fr)

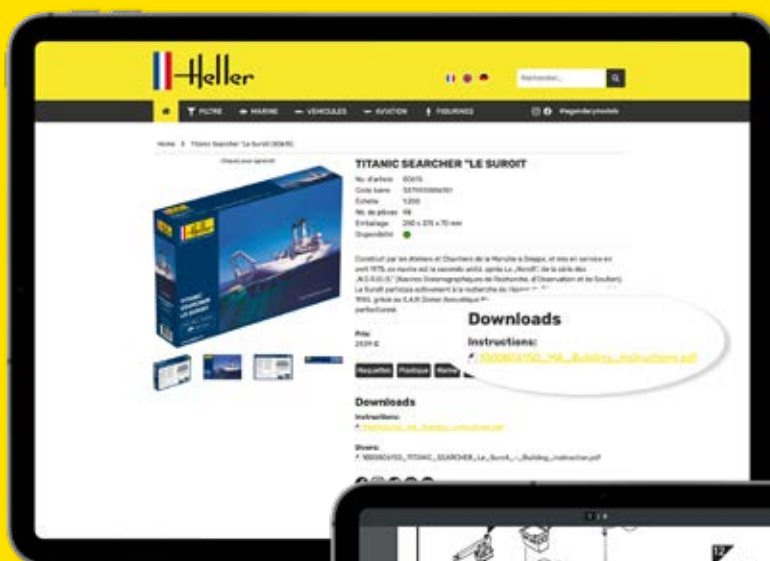

Choisissez l'article que vous désirez et téléchargez les instructions.
Choose your desired article and download the instructions.
Wählen Sie den gewünschten Artikel und laden Sie die Anleitung herunter.



**Download all
instructions!**

Grossissement des instructions pour
une vue détaillée.

Enlarge the instructions for a more
detailed view.

Vergrößern Sie die Anleitung für eine
detailliertere Ansicht.

V-070421

Service consommateurs
Pour toute demande de SAV, connectez-vous
sur notre site www.heller.fr.

Customer Service
For after-sales service requests,
please contact us through our website
www.heller.fr.

Endverbraucherservice
Bitte besuchen Sie uns auf www.heller.fr
für alle Ersatzteilanfragen.

Heller Hobby GmbH

Erlenbacher Str. 3 • 42477 Radevormwald • GERMANY

☎ +49 (0) 2195-92773-0 ✉ info@heller.fr