

CITROËN MEHARI



80760

La Citroën Méhari fut produite entre 1968 et 1987, toutefois toutes les pièces, carrosserie et châssis compris, sont toujours disponibles aujourd'hui. Cette voiture légère fut conçue par un ancien aviateur du célèbre Normandie Niémen, le comte Roland Paulze d'Ivoy de la Poype (décédé en 2012). Elle est constituée d'une coque en plastique ABS installée sur une tubulure accrochée au châssis-plateforme de la Dyane. Sa conception est fidèle à la doctrine appliquée à d'autres véhicules de la marque aux chevrons, basée sur la réutilisation d'ensembles complets : volant de la 2 cv, feux du fourgon HY, etc. C'est une voiture deux places qui peut néanmoins emporter quatre passagers. Elle fut commercialisée en différentes couleurs, le vert « Montana » étant la seule à avoir couvert toutes les années de production. Un modèle 4x4 fut développé en 1979, distinguable par sa roue de secours sur le capot avant et quelques changements mécaniques. Il n'est pas rare de la croiser çà et là, car une voiture parfaite pour les loisirs et les balades en plein air.

Spécifications

Longueur : 3,50 m
Largeur : 1,53 m
Hauteur : 1,54m
Empattement : 2,37m
Voie av/arr : 1,26 m
Vitesse max : 120 km/h
Moteur : bicylindre à plat de 602 cm³ refroidi par air
Masse à vide : 525 kg
PTC : 715 kg
Boite de vitesse 4 rapports

The Citroën Méhari was produced between 1968 and 1987, however all of its spare parts, including the body and chassis, are still available today. This light vehicle was designed by a former pilot from the famous Normandie Niemen Regiment, Count Roland Paulze d'Ivoy de la Poype (deceased in 2012). It is comprised of an ABS plastic shell installed on tubing attached to the chassis/platform of the Citroën Dyane. Its design is in keeping with the doctrine applied to the other vehicles of the chevron-patterned brand, based on the re-use of complete sets: the 2CV's steering wheel, the HY van's headlights, etc. It is a two-seat car that can nonetheless carry four passengers. It was sold in various colours, with «Montana» green being the only colour to span all years of production. A 4x4 model was developed in 1979, whose points of distinction were its spare tire on the front bonnet and a few mechanical changes. It is not uncommon to come across it here and there, since it is a car that is perfectly suited for leisure time and country drives.

Spécifications

Length: 3.50 m
Width: 1.53 m
Height: 1.54 m
Wheelbase: 2.37 m
Front/back axle track: 1.26 m
Max. speed: 120 km/h
Engine: 602 cm³ air-cooled flat two-cylinder
Empty weight: 525 kg
Gross vehicle weight rating: 715 kg
4-speed gearbox

La Citroën Mehari fu prodotta tra il 1968 e il 1987; tuttavia, tutti i pezzi, carrozzeria e telaio compresi, sono sempre disponibili ancora oggi. Questa automobile leggera fu concepita da un ex aviatore del celebre Normandie-Niemen, il conte Roland Paulze d'Ivoy de la Poype (deceduto nel 2012). Era costituita da una scocca in plastica ABS installata su un tubo agganciato al telaio a pianale della Dyane. La sua ideazione è fedele alla dottrina applicata ad altri veicoli della casa automobilistica, basata sul riutilizzo di serie complete: volante della 2 cv, fari del furgone HY, ecc. È una vettura a due posti che può tuttavia trasportare quattro passeggeri. Fu commercializzata in diversi colori, ma solo il verde «Montana» ha coperto tutte le annate di produzione. Nel 1979 fu sviluppato un modello 4x4, contraddistinto dalla ruota di scorta sul cofano e qualche modifica meccanica. Non è raro incrociarla qua e là, perché è l'automobile perfetta per il tempo libero e le gite all'aria aperta.

Specifiche

Lunghezza: 3,50 m
Larghezza: 1,53 m
Altezza: 1,54 m
Interasse: 2,37 m
Carreggiata ant/post: 1,26 m
Velocità max.: 120 km/h
Motore: bicilindrico a cilindri contrapposti 602 cm³ raffreddato ad aria
Massa a vuoto: 525 kg
PTT: 715 kg
Cambio 4 rapporti

De Citroën Méhari werd tussen 1968 en 1987 in productie genomen. Alle onderdelen, waaronder de carrosserie en het chassis, zijn echter vandaag de dag nog steeds beschikbaar. Dit lichte voertuig werd ontworpen door een ex-piloot van het vermaarde Normandie Niémen regiment, de graaf Roland Paulze d'Ivoy de la Poype (overleden in 2012). Het voertuig is opgebouwd uit een kunststof ABS-romp die is geïnstalleerd op een buizenstelsel dat op zijn beurt aan een chassisplatform is vastgemaakt. Het ontwerp is trouw aan de bestaande principes die tevens op de andere voertuigen van het merk met het zigzagmotief werden toegepast en is gebaseerd op het hergebruiken van volledige groepen: stuur van de 2PK, lichten van de HY bestelwagen, etc. Het voertuig werd in verschillende kleuren op de markt gebracht. De groene «Montana» is echter het enige model dat gedurende de volledige fabricageperiode werd gemaakt. Een 4x4 model werd in 1979 ontwikkeld en is te onderscheiden door zijn reservewiel op de motorkap aan de voorkant en enkele mechanische aanpassingen. Het is niet verwonderlijk als u deze auto hier en daar kruist, het is namelijk een perfecte wagen om leuke ritjes in de open lucht te maken.

Specificaties

Lengte: 3,50 m
Breedte: 1,53 m
Hoogte: 1,54m
Wielbasis: 2,37m
Sporbreedte vooraan/achteraan: 1,26 m
Max. snelheid: 120 km/u
Motor: luchtgekoelde tweecilinder boxermotor van 602 cm³
Tarra gewicht: 525 kg
MTG: 715 kg
Versnellingsbak met 4 versnellingen kg
PTT: 715 kg
Cambio 4 rapporti

O Citroën Méhari foi produzido entre 1968 e 1987. No entanto, todas as peças, carroçaria e chassis incluídos, ainda hoje se encontram disponíveis. Este automóvel ligeiro foi criado por um antigo aviador do famoso Normandie Niemen, o Comandante Roland Paulze de Ivoy de la Poype (faleceu em 2012). Ele é constituído por uma estrutura de plástico ABS instalada numa tubuladura fixada ao chassis-plataforma da Dyane. A sua conceção é fiel à doutrina aplicada a outros veículos da marca dos galões, baseada na reutilização de conjuntos completos: Volante do 2 cv, faróis do furgão HY, etc. É um automóvel de dois lugares que, no entanto, pode levar quatro passageiros. Ele foi comercializado em diferentes cores, sendo o verde «Montana» a única a ter abrangido todos os anos de produção. Em 1979, foi desenvolvido um modelo 4x4, que se distinguia pela sua roda sobresselente sobre o capô e algumas mudanças mecânicas. Não é raro cruzarmo-nos com ele de vez em quando, pois é um automóvel perfeito para lazer e passeios ao ar livre.

Características técnicas

Comprimento: 3,50 m

Largura: 1,53 m

Altura: 1,54m

Distância entre eixos: 2,37m

Eixo dianteiro/traseiro: 1,26 m

Velocidade máxima: 120 km/h

Motor: Bicilíndrico plano de 602 cm³ arrefecido a ar

Peso sem carga: 525 kg

Peso total com carga: 715 kg

Caixa de 4 velocidades

Модель Citroën Méhari выпускалась с 1968 по 1987 год, однако детали, кузов и даже шасси до сих пор имеются в продаже. Этот очень легкий автомобиль разработал бывший летчик знаменитого авиационного полка Нормандия-Неман граф Ролан Польз д'Ивуа де ла Пуап (Roland Paulze d'Ivoy de la Poype) (умер в 2012 году). Кузовные детали автомобиля выполнены из ABS-пластика, двигатель с воздушным охлаждением установлен на шасси модели Dyane. Концепция соответствует доктрине, применяемой ко всем автомобилям марки, смысл которой состоит в повторном использовании целых комплектов деталей: руль от 2 CV, фары от фургона HY и т. д. Это двухместный автомобиль, способный перевозить четырех пассажиров. Модель выпускалась в различных цветах, при этом зеленый цвет «Montana» был единственным, представленным на рынке в течение всего срока существования автомобиля. Полноприводная модификация появилась в 1979 году. Отличительные черты — запасное колесо на капоте и некоторые механические изменения. Этот автомобиль не редкость и на современных дорогах, ведь он идеален для отдыха и активного времяпрепровождения на природе.

Характеристики

Длина: 3,50 м

Ширина: 1,53 м

Высота: 1,54 м

Колесная база: 2,37 м

Передняя/задняя колея: 1,26 м

Макс. скорость: 120 км/ч

Двигатель: двухцилиндровый с воздушным охлаждением объемом 602 см³

Масса без нагрузки: 525 кг

Максимальная разрешенная масса: 715 кг

4-ступенчатая коробка передач

Der Citroën Méhari wurde zwischen 1968 und 1987 produziert, doch alle seine Ersatzteile, einschließlich der Karosserie und des Fahrgestells, sind auch heute noch erhältlich. Dieses Leichtfahrzeug wurde von einem ehemaligen Piloten des berühmten Normandie-Niemen-Geschwader entworfen, dem Grafen Roland Paulze d'Ivoy de la Poype (verstorben 2012). Das Auto bestand aus einer ABS-Kunststoff-Karosserie, die auf einem Rohrsystem montiert war, das am Fahrgestell des Citroën-Dyane befestigt war. Sein Konzept ist im Einklang mit der Doktrin, die auch auf die anderen Fahrzeuge der Marke mit dem Doppelwinkel angewandt wird. Diese Doktrin basiert auf der Wiederverwendung der kompletten Baugruppe: das Lenkrad des 2 CV, Signallichter des HY-Kastenwagens usw. Er ist ein Zweisitzer, der jedoch vier Personen befördern kann. Der Citroën Méhari wurde in verschiedenen Farben verkauft, wobei der grüne „Montana“ das einzige Modell war, das während der gesamten Produktionszeit angeboten wurde. 1979 wurde ein Allradantriebsmodell entwickelt, das sich durch sein Reserverad auf der Fronthaube sowie einige mechanische Änderungen unterschied. Man läuft ihm recht häufig über den Weg, denn er ist das perfekte Freizeitauto für Spazierfahrten an der frischen Luft.

Technische Daten

Länge: 3,50 m

Breite: 1,53 m

Höhe: 1,54 m

Radstand: 2,37 m

Spurweite vorne/hinten: 1,26 m

Höchstgeschwindigkeit: 120 km/h

Motor: luftgekühlter 602 cm³ Zweizylinderboxermotor

Leergewicht: 525 kg

Gesamtgewicht: 715 kg

Vierganggetriebe

Boite de vitesse 4 rapports

MODEL / DIMENSIONS
SIZE / DU MODELE

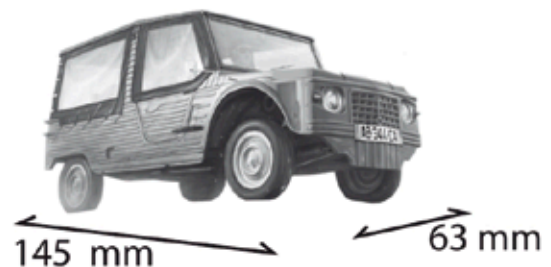

RECOMMENDED PAINTS / PEINTURES RECOMMANDEES



N°80



N°71



N°18



N°21



N°33



N°19

ADDITIONAL PAINTS / PEINTURES COMPLEMENTAIRES



N°11



N°22



N°61



N°14



N°69

n°11 argent - silver - silber
 n°14 bleu de France - medium blue - blau
 n°18 orange
 n°19 rouge - red - rot
 n°21 noir brillant - shiny black - schwarz glänzend
 n°22 blanc - white - weiss

n°33 noir mat - matte black - matt schwarz
 n°61 chair mat - mate flesh - matt fleisch
 n°69 jaune brillant - bright yellow - helles Gelb
 n°71 chêne satiné - oak stain - Eiche satin
 n°80 vert pré - green - grün

1

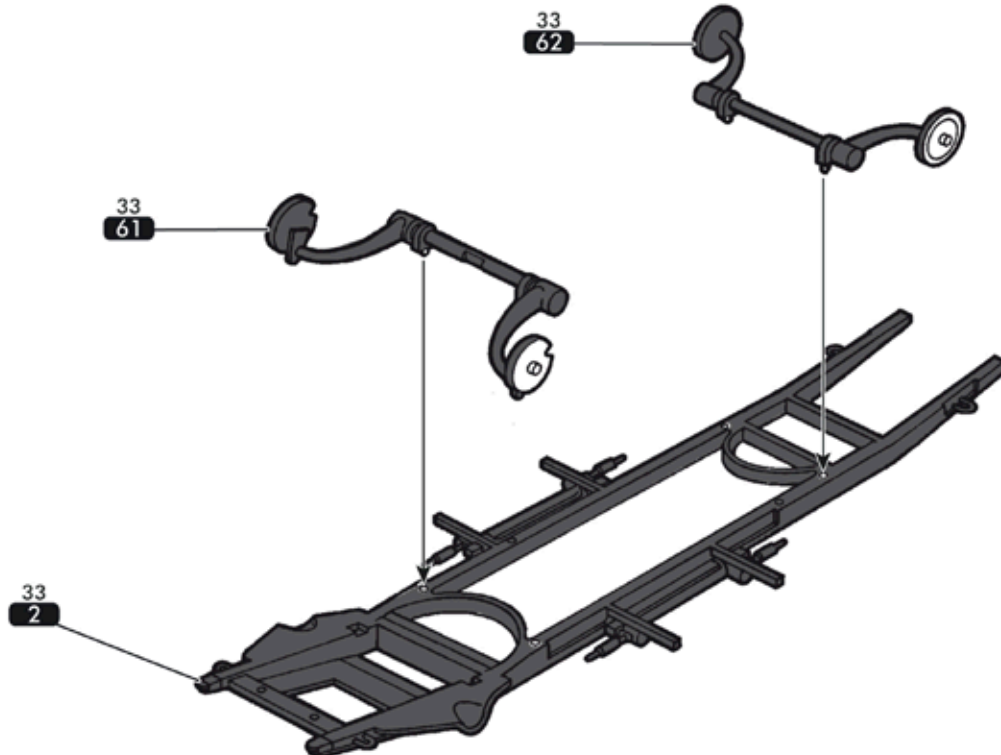

2

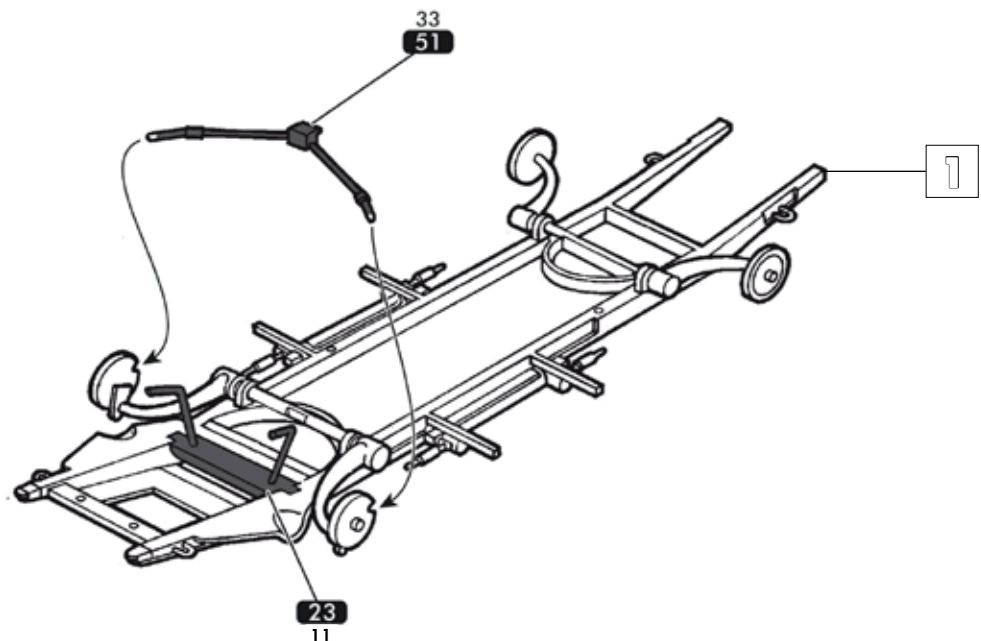

3

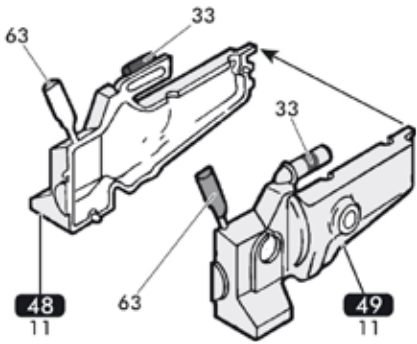

4

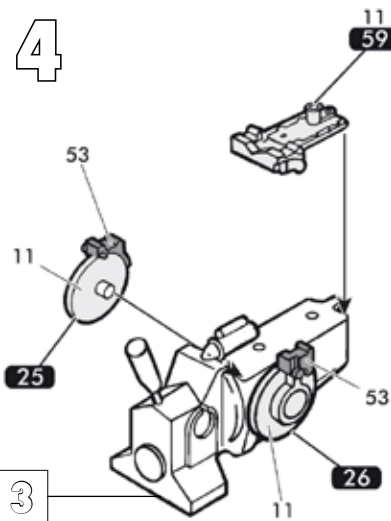

5

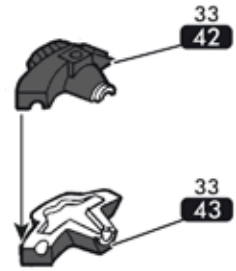

6

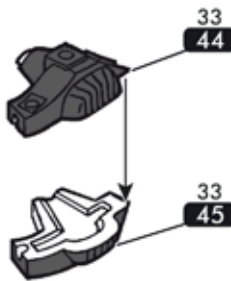

7

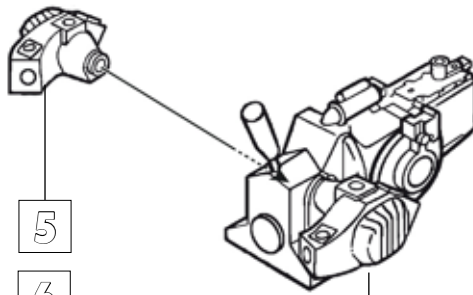

8

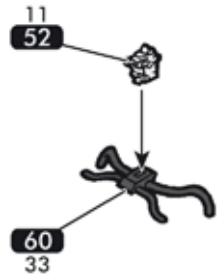

9

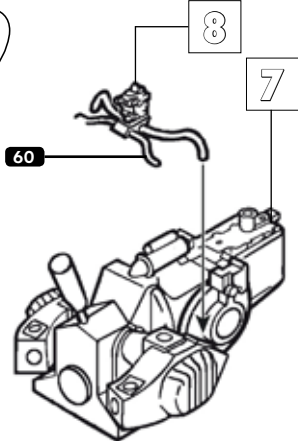

10

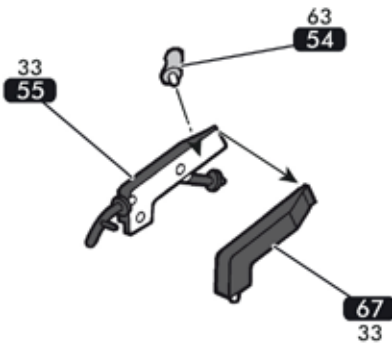

11

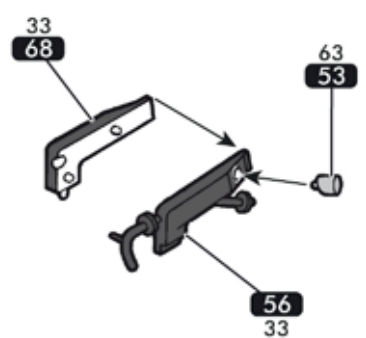

10

12

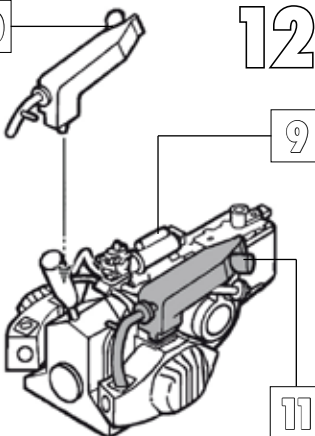

13

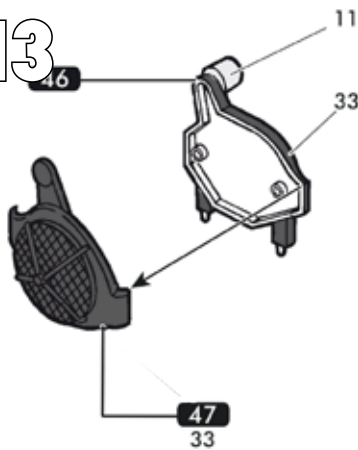

14

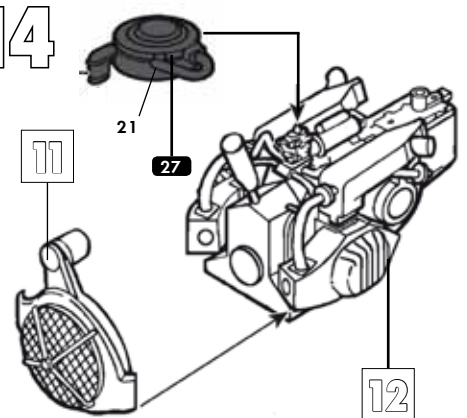

15

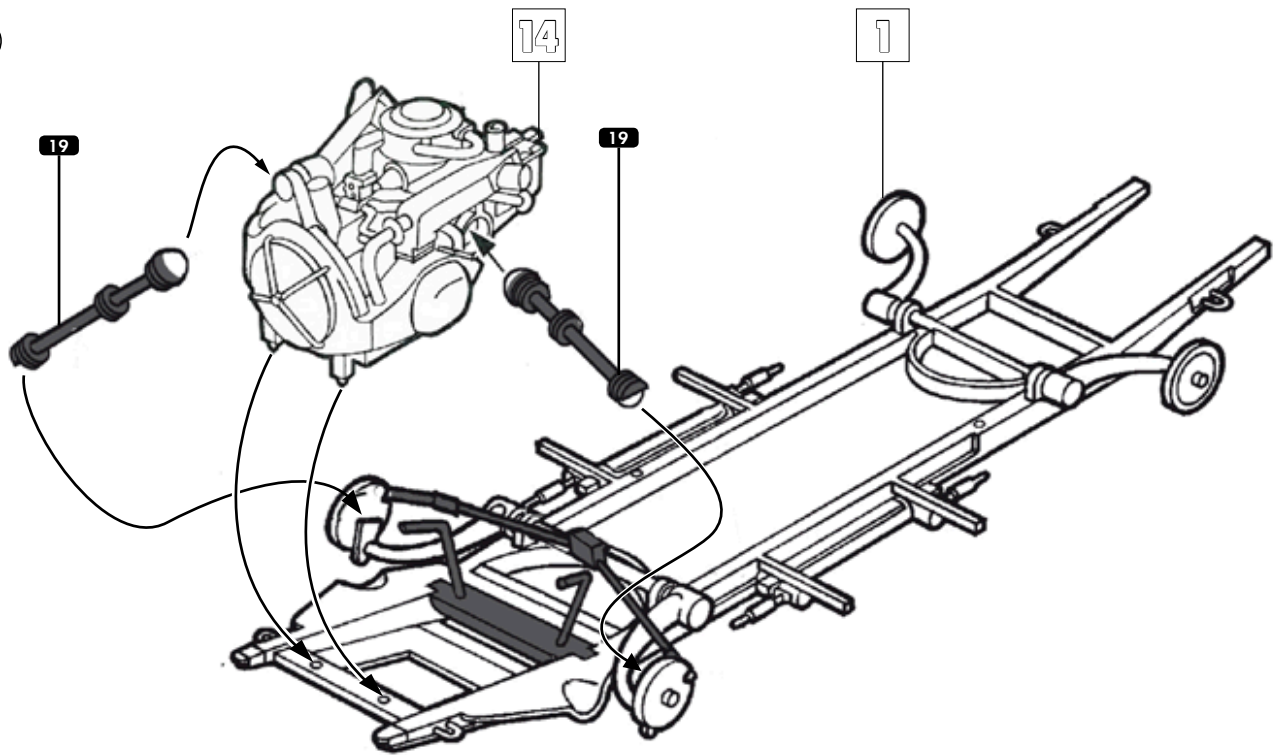

16

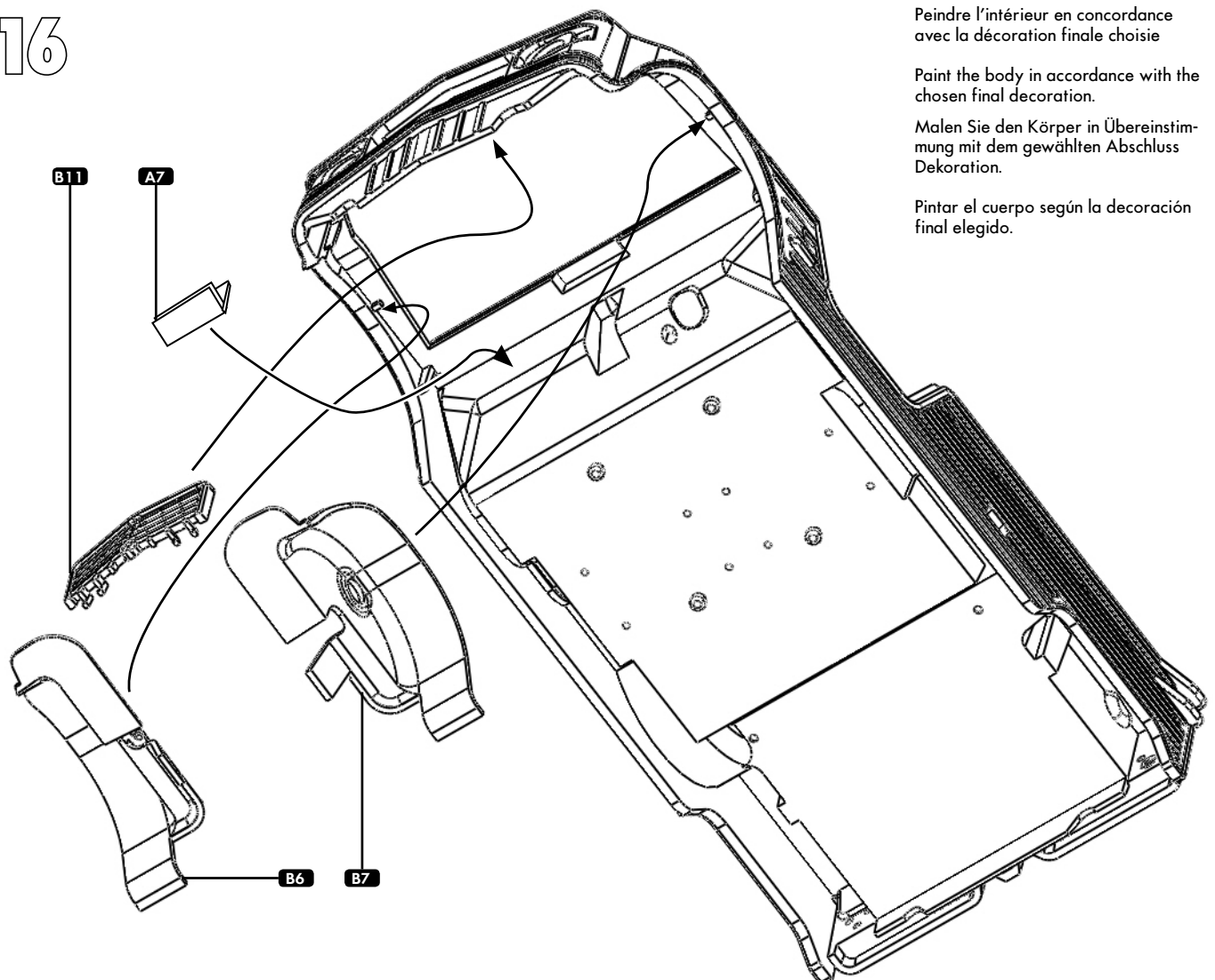

Peindre l'intérieur en concordance avec la décoration finale choisie

Paint the body in accordance with the chosen final decoration.

Malen Sie den Körper in Übereinstimmung mit dem gewählten Abschluss Dekoration.

Pintar el cuerpo según la decoración final elegido.

17

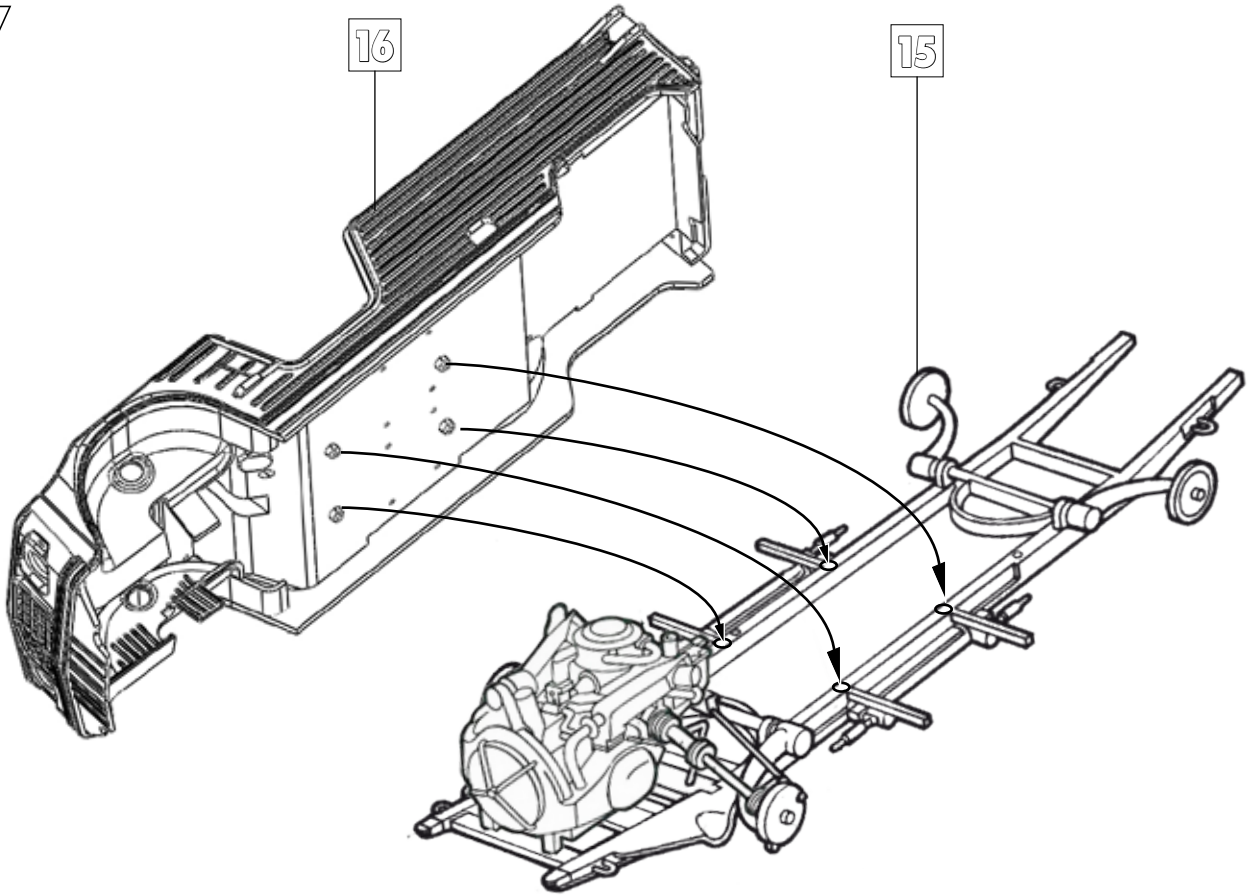

18

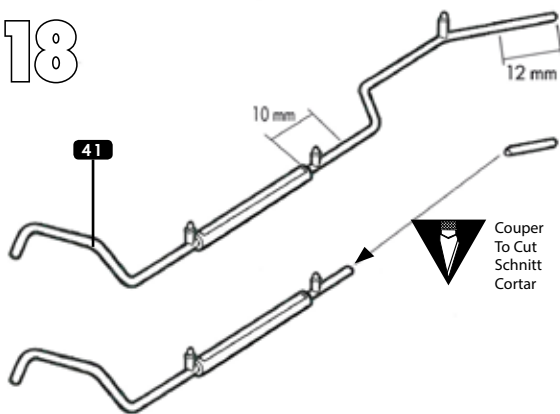

19

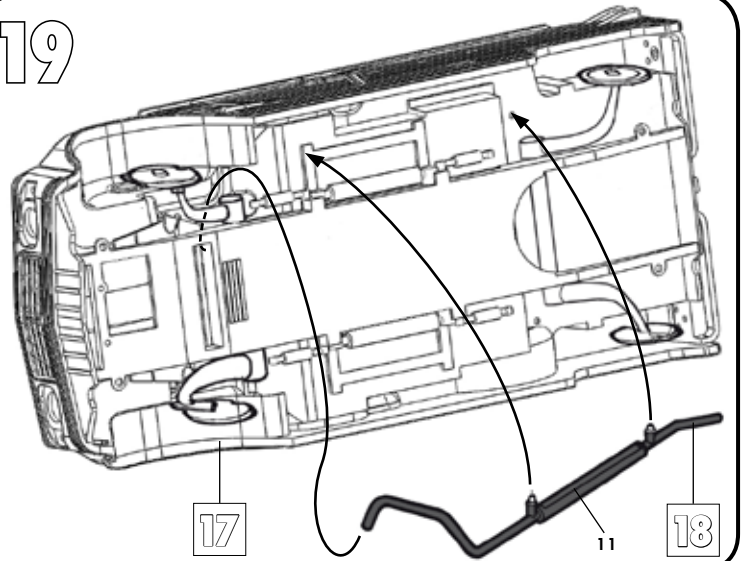

20

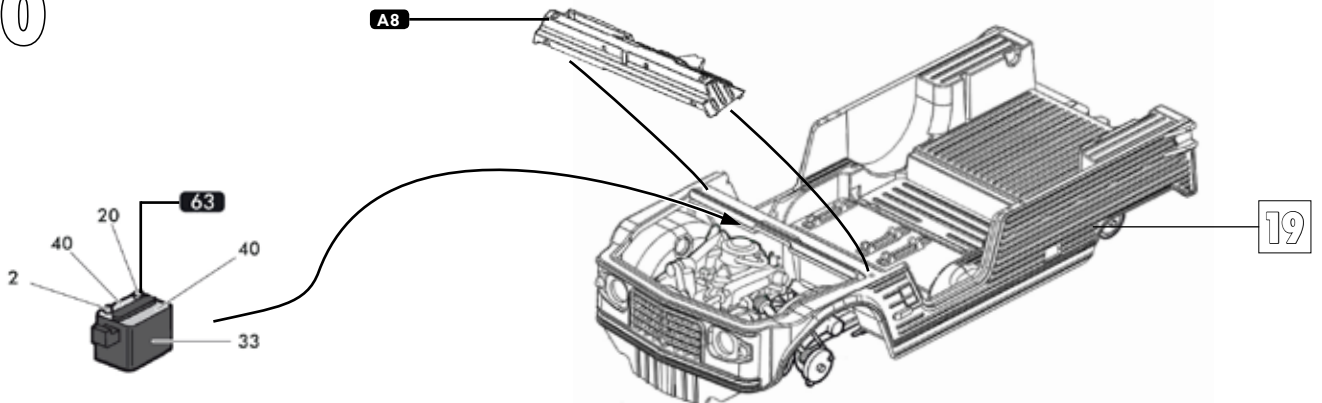

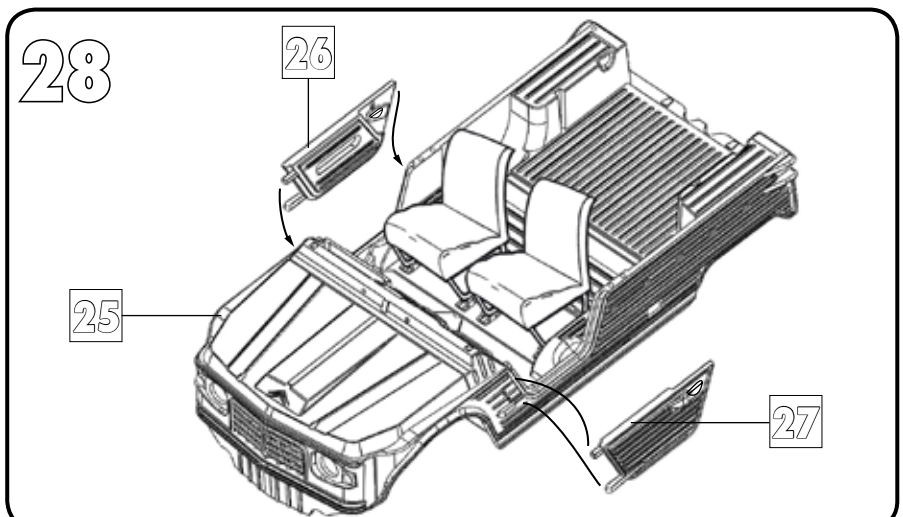
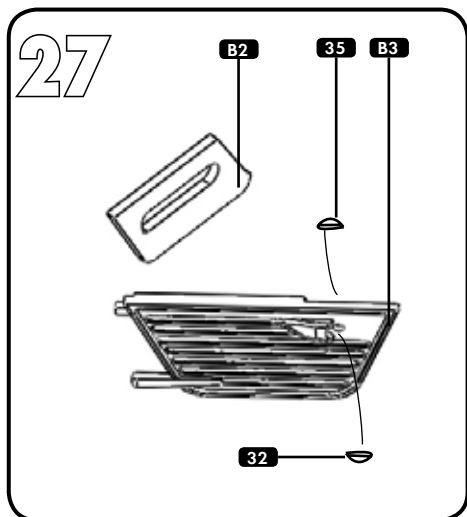
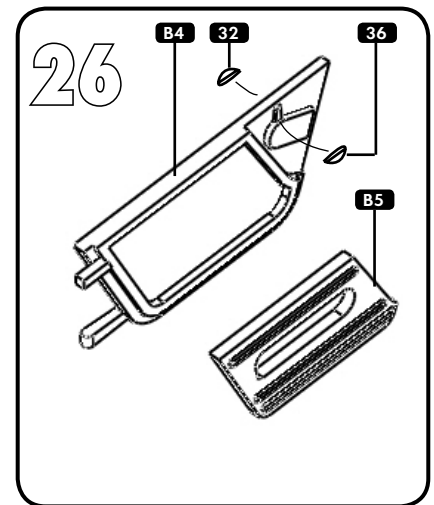
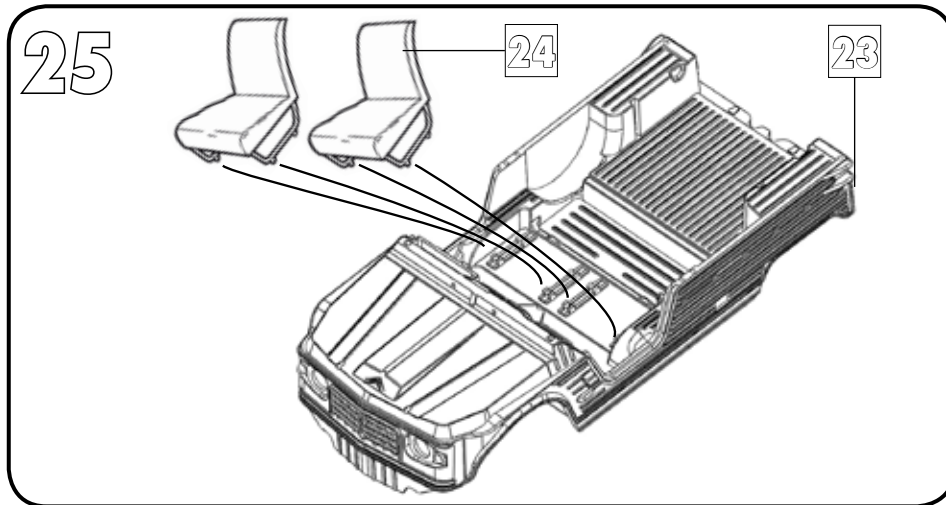
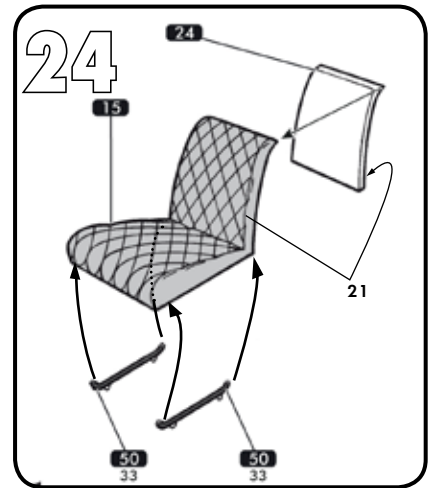
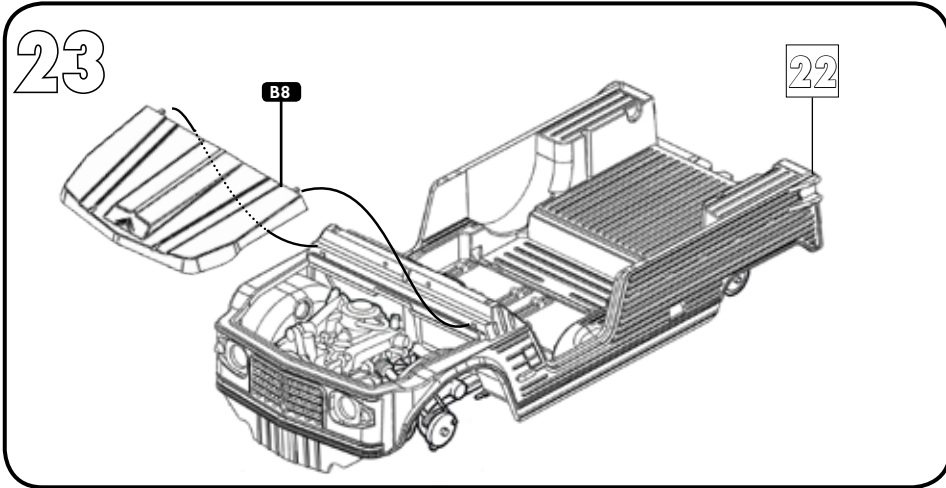
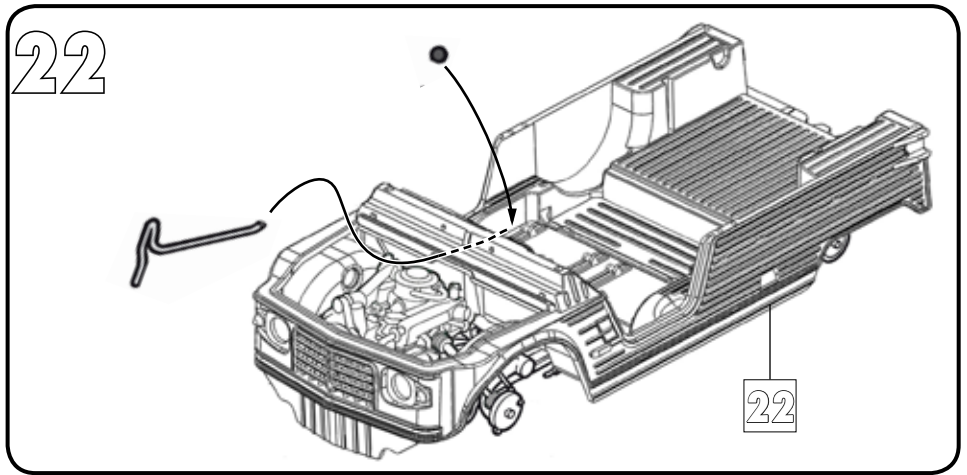
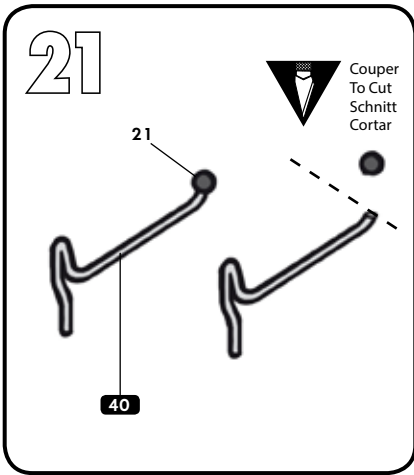

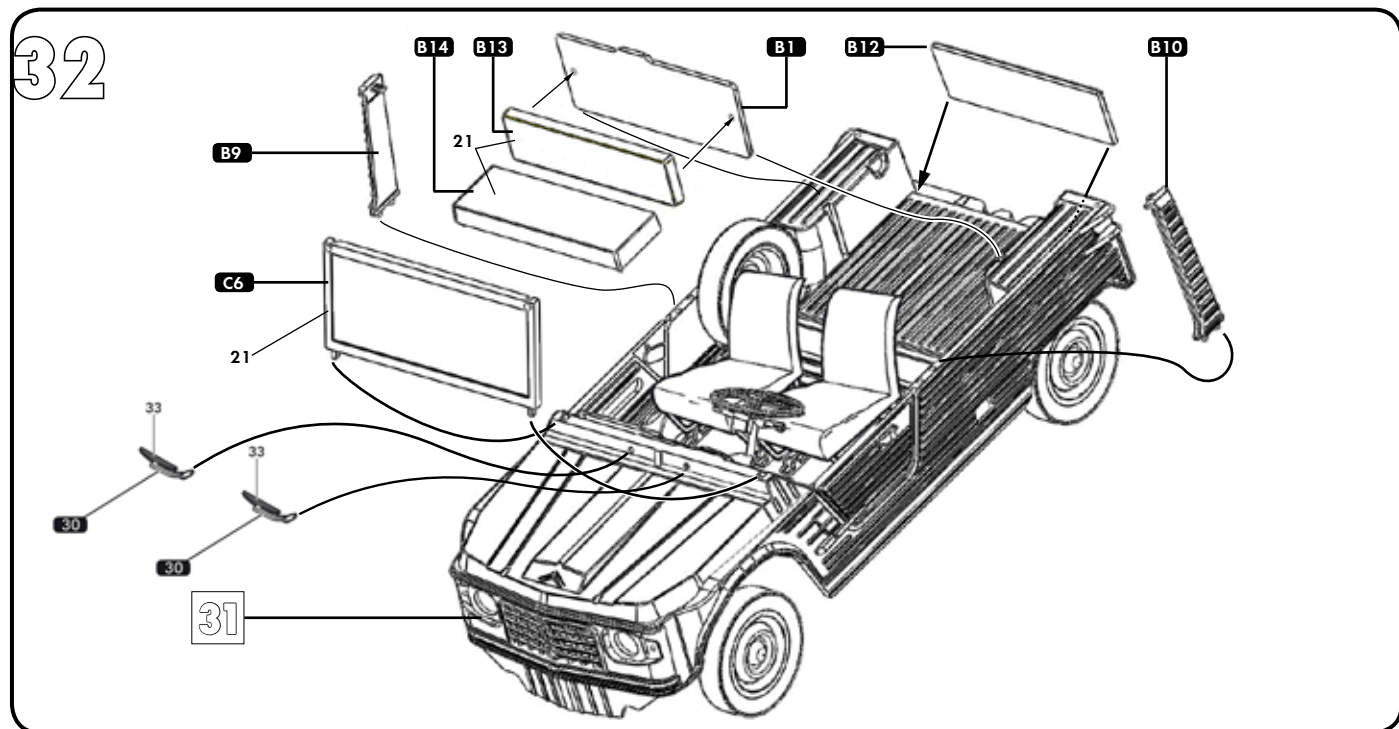
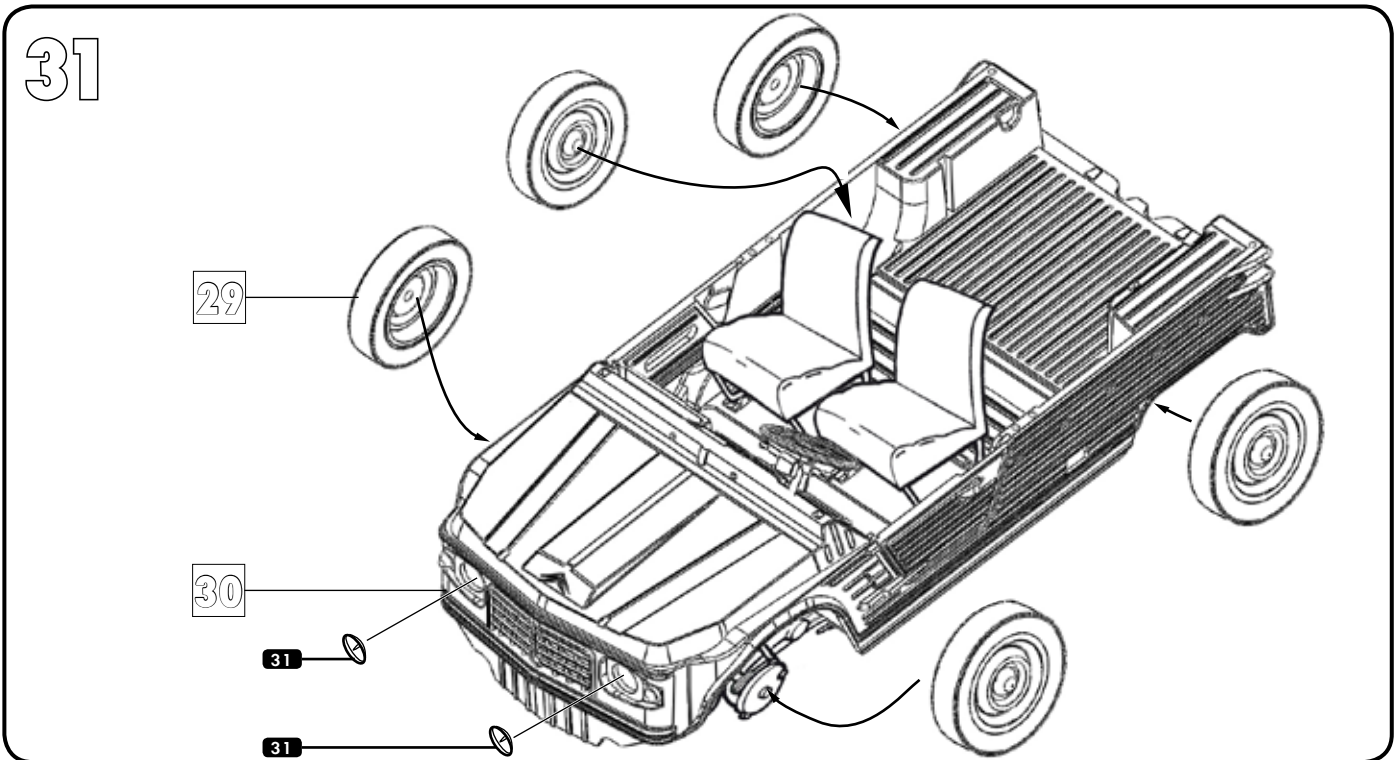
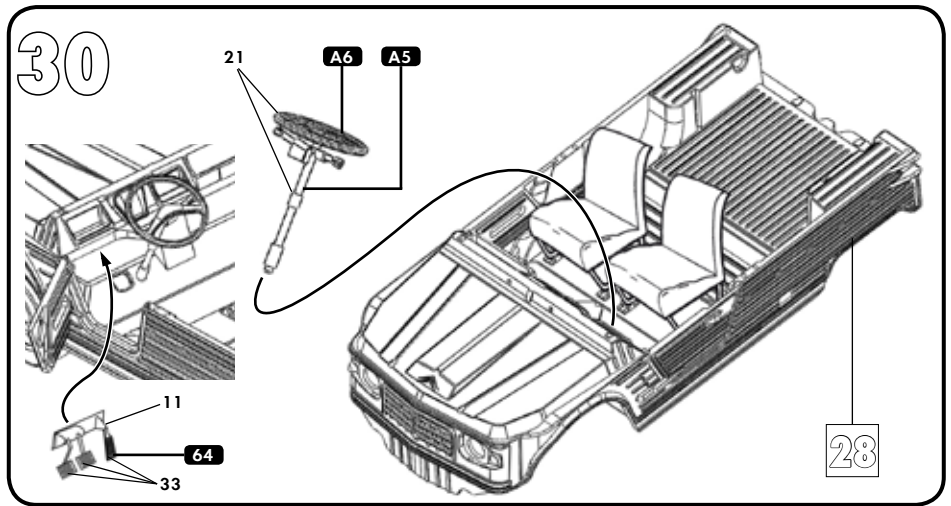
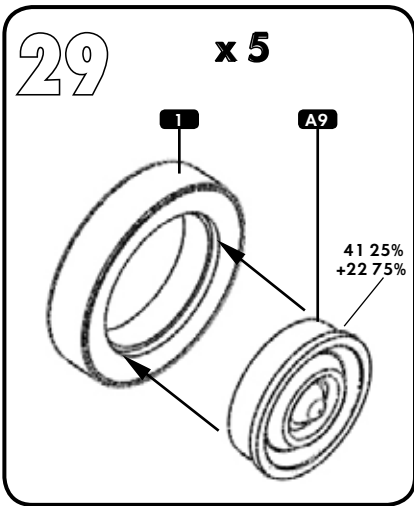

33

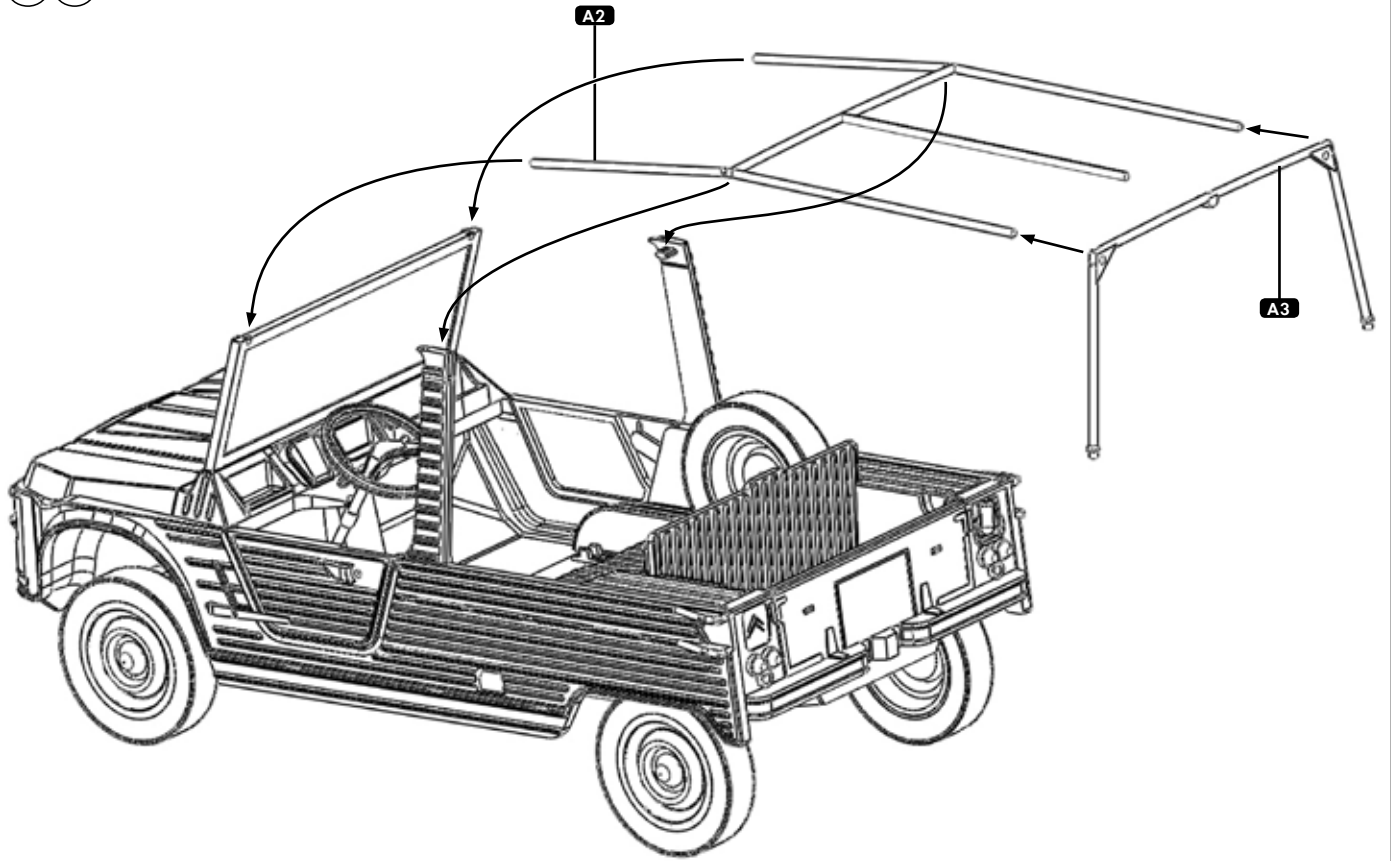

34

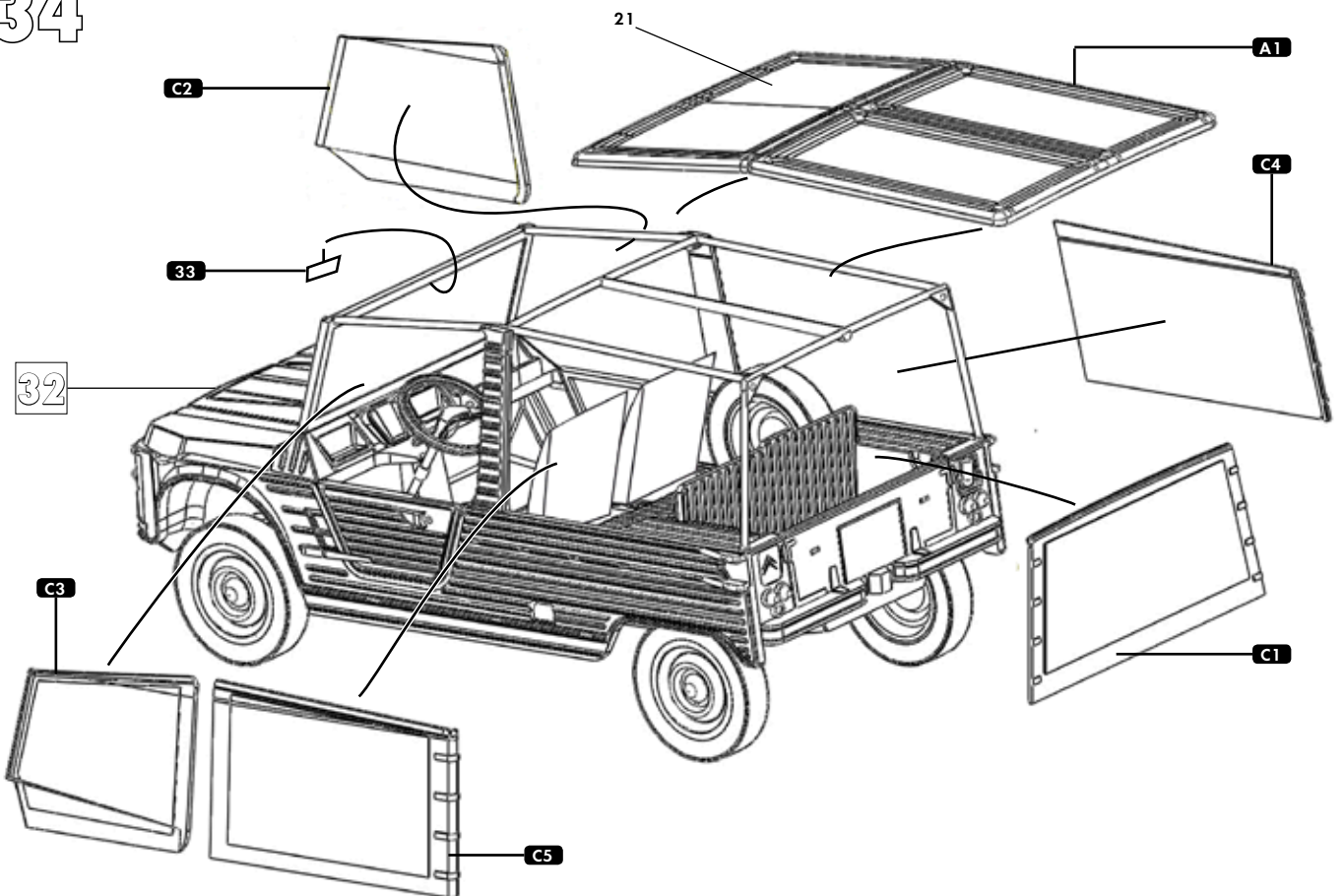

35

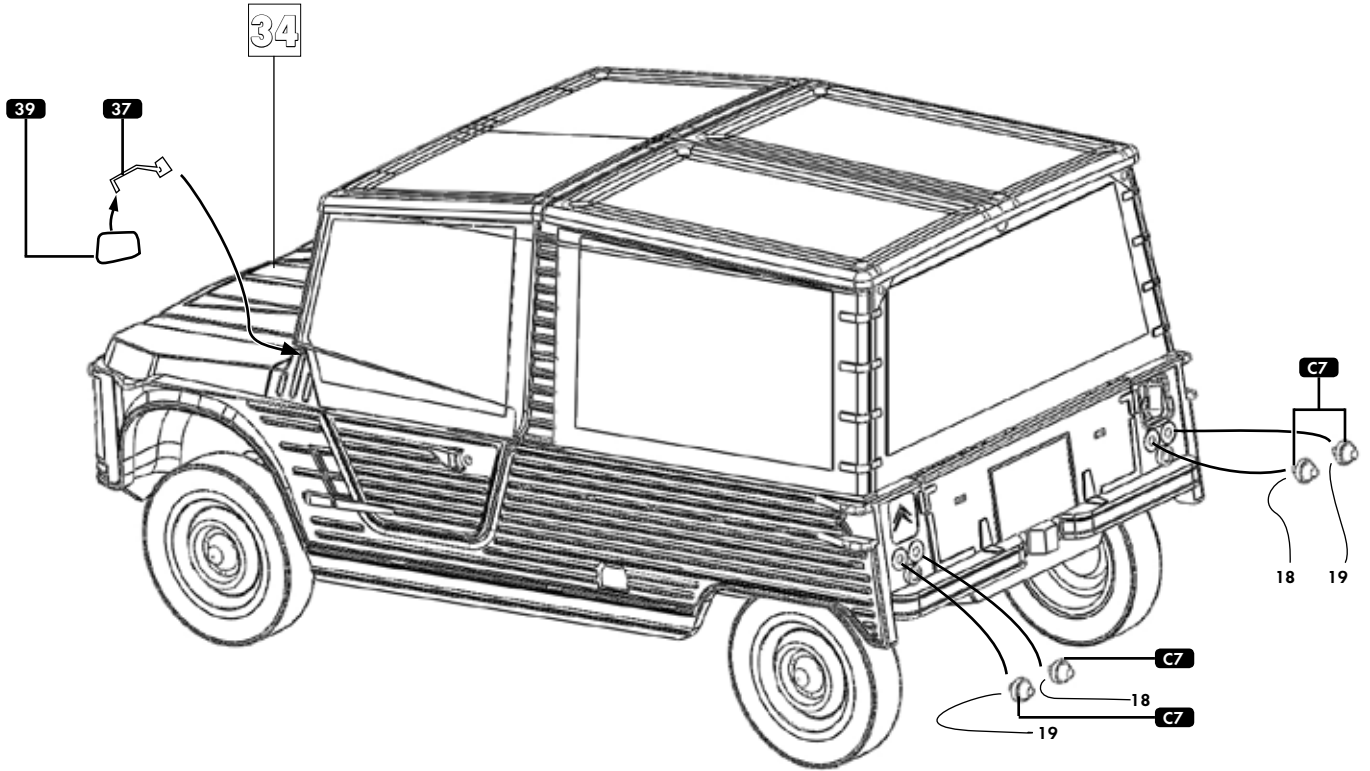



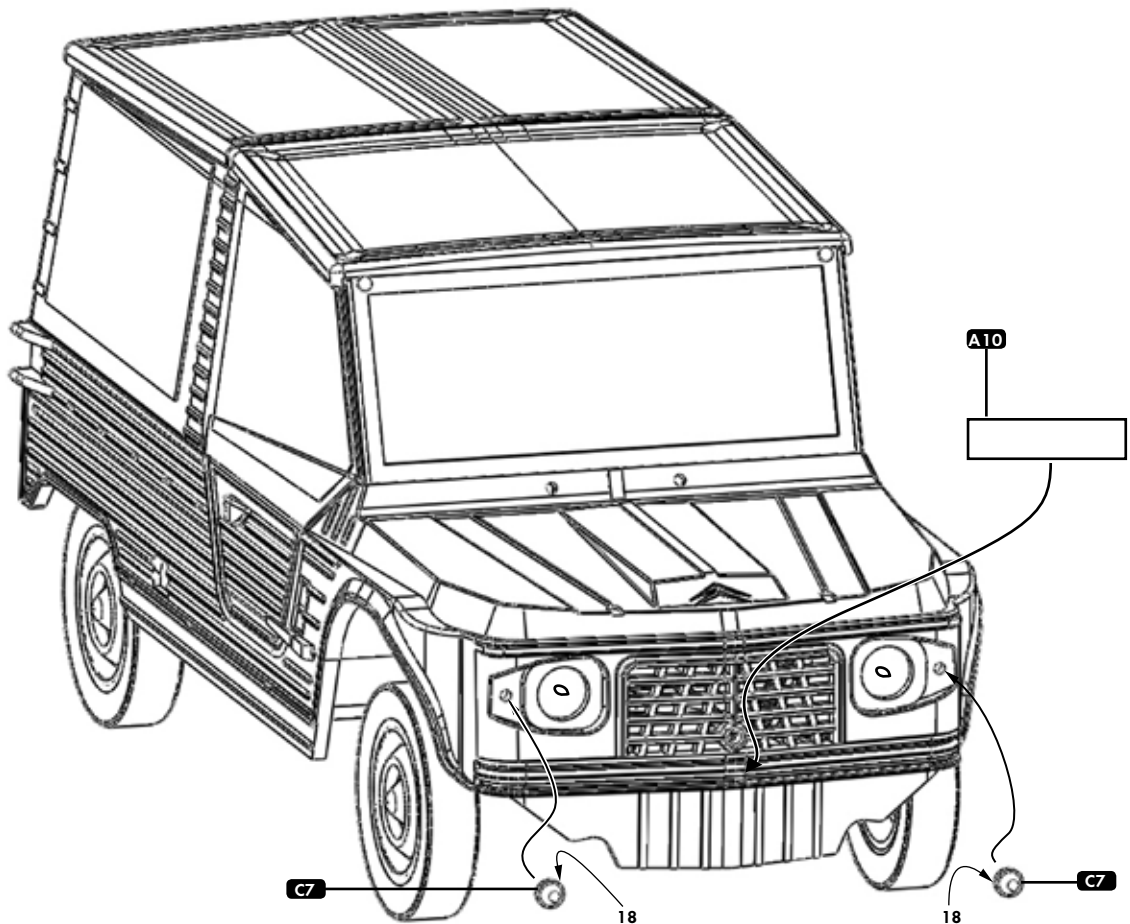

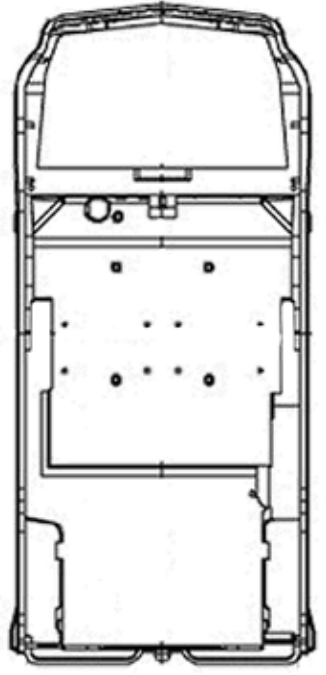
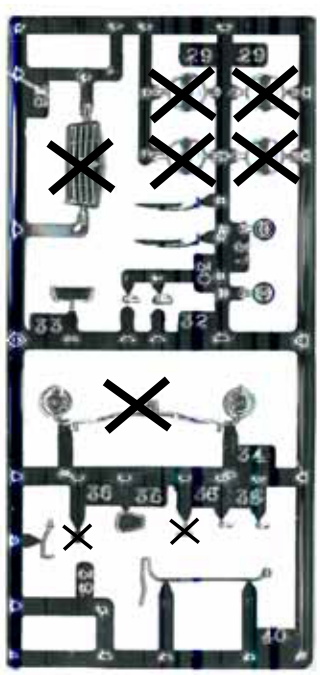
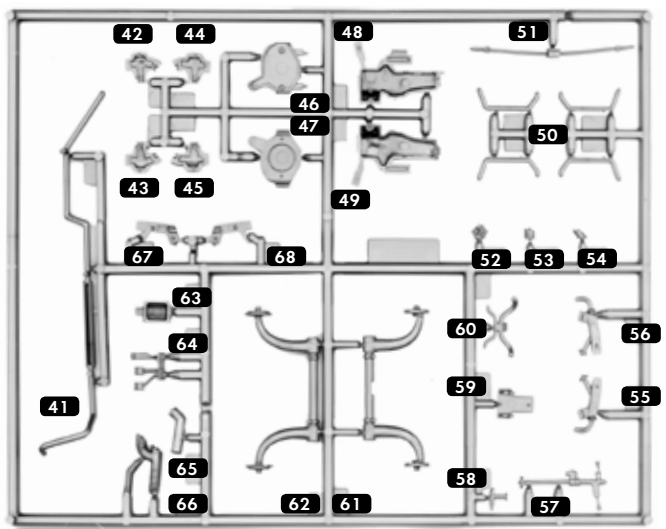
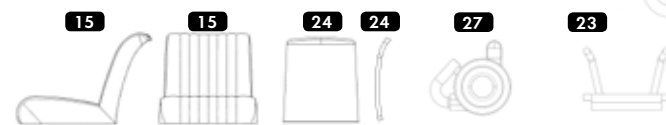
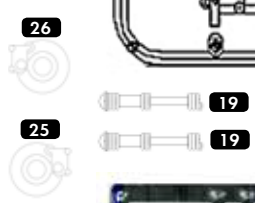
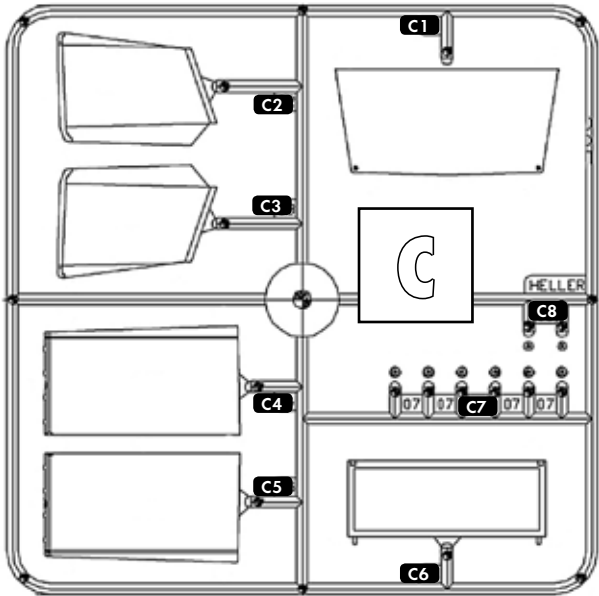
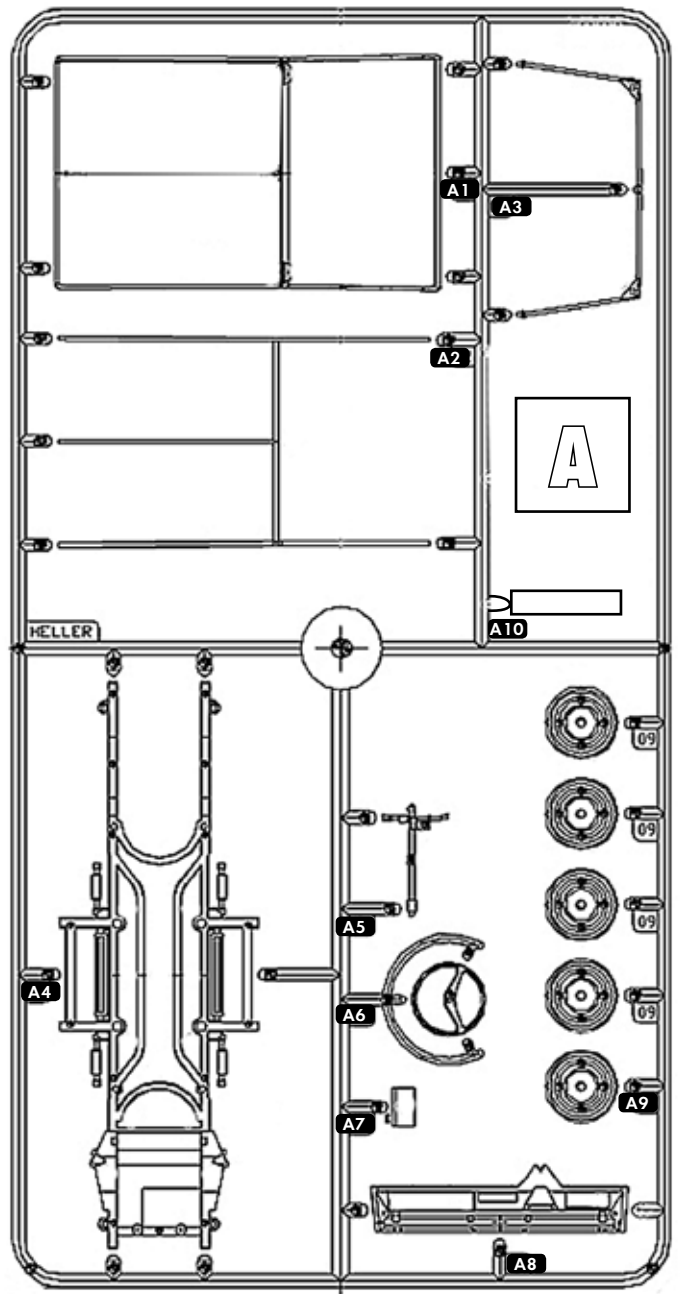
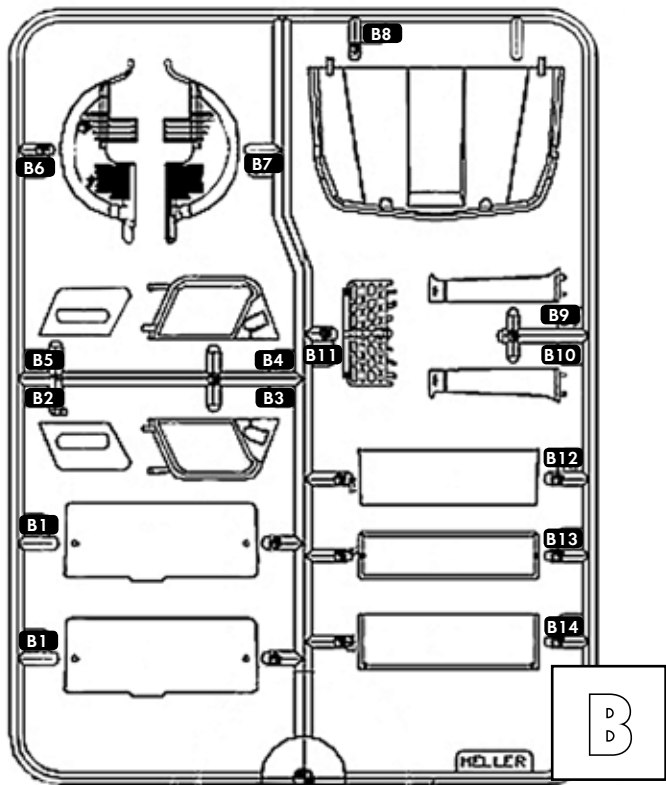



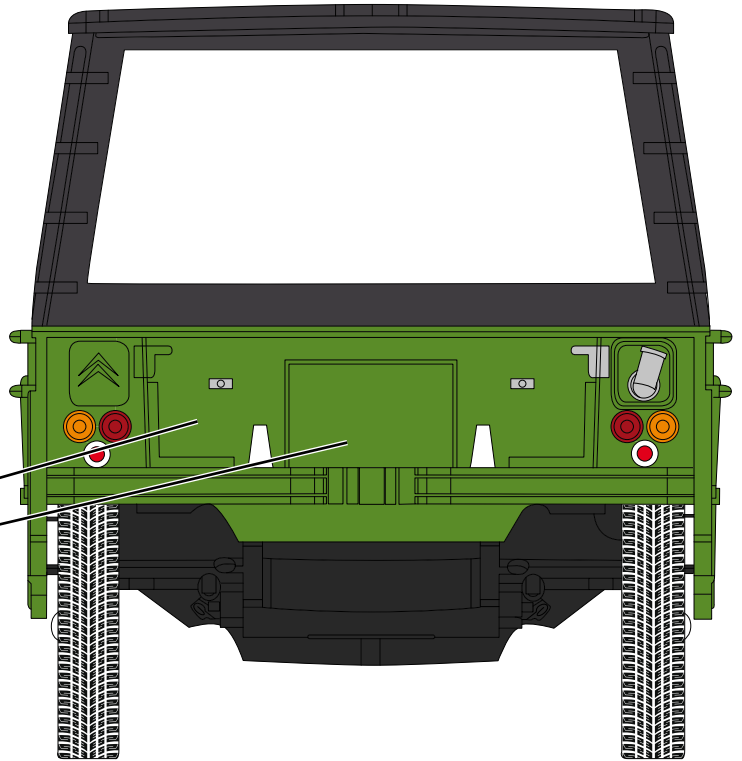
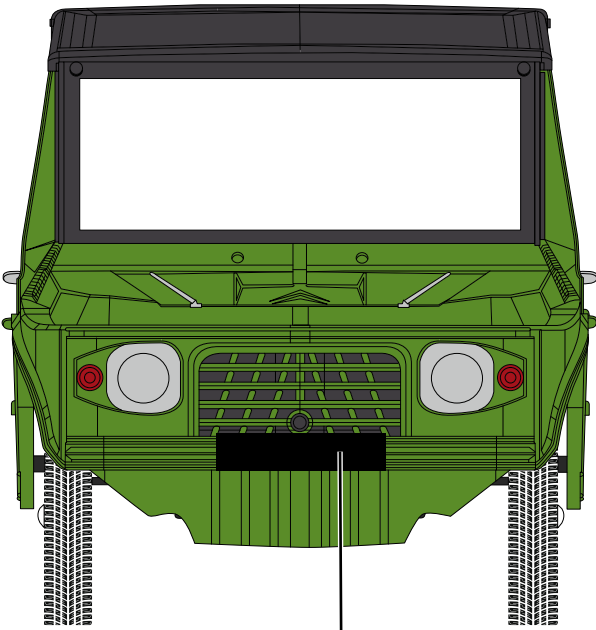









36





vert Montana
1968 - 1987



 DH - 822 - QL 	 BV - 648 - DE 
 DH - 822 - QL 	 BV - 648 - DE  
 BF - 861 - EZ 	 856 VM 61
 BF - 861 - EZ  	 856 VM 61 

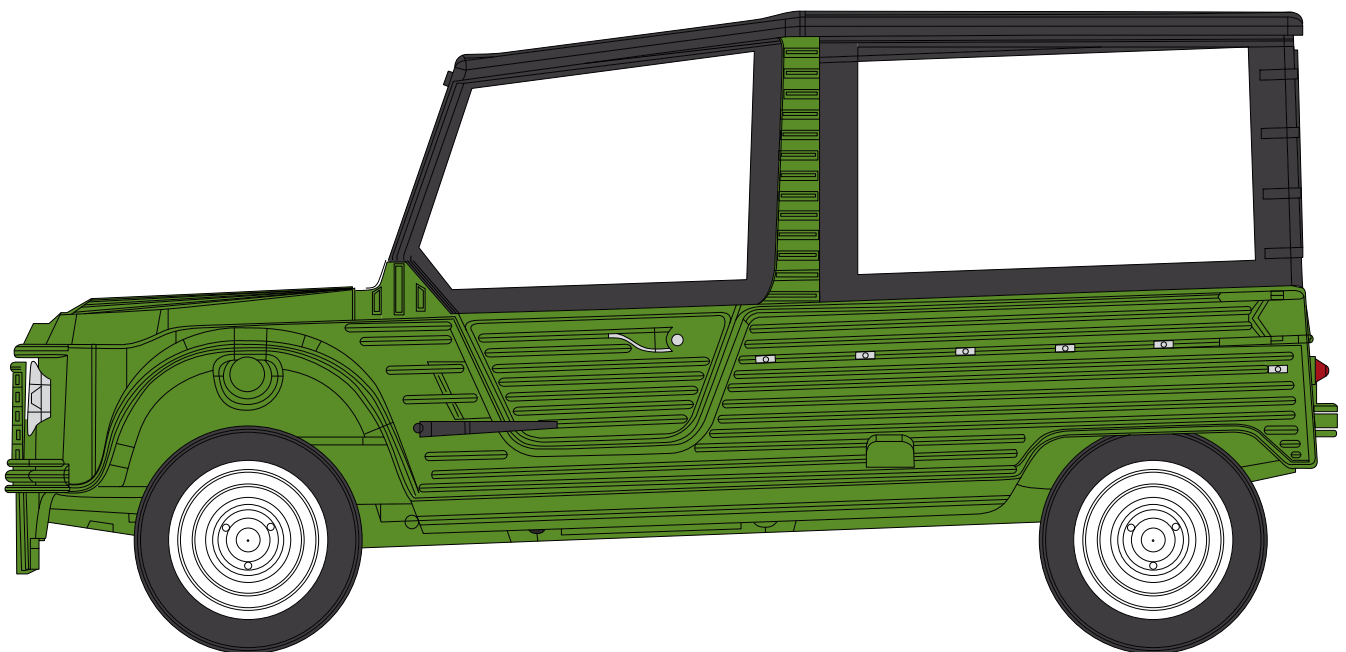

80760

beige Kalahari
1968 - 1977

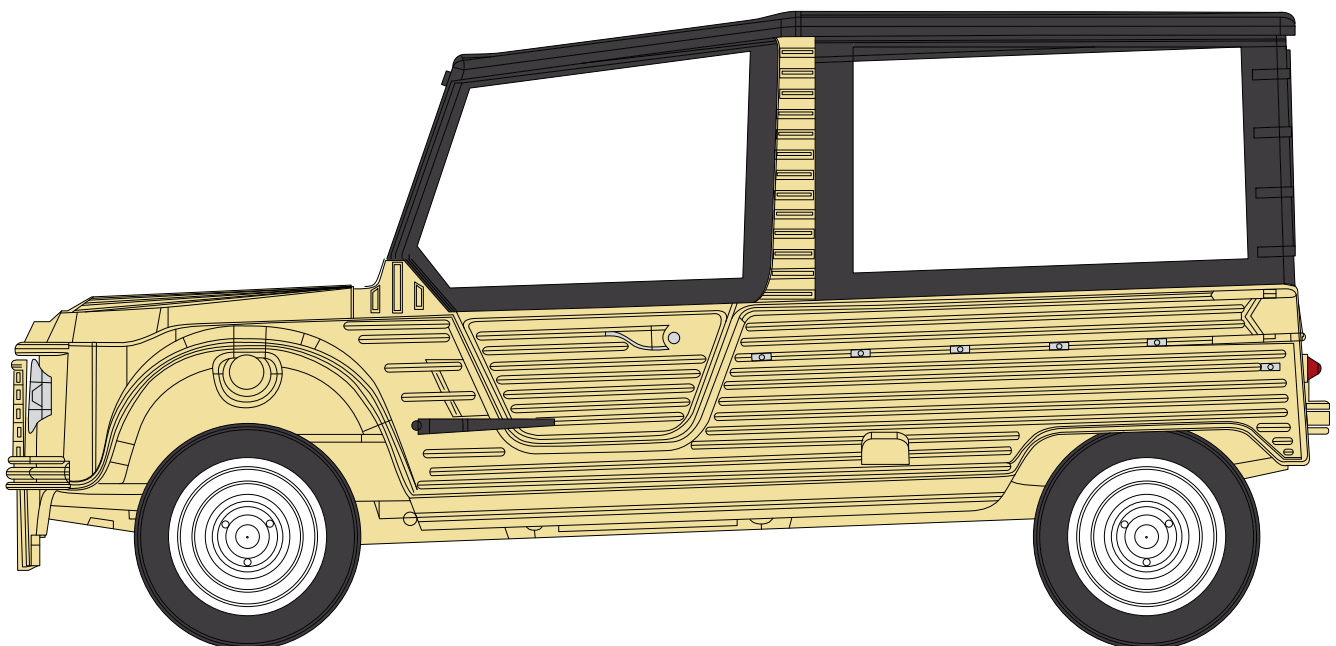
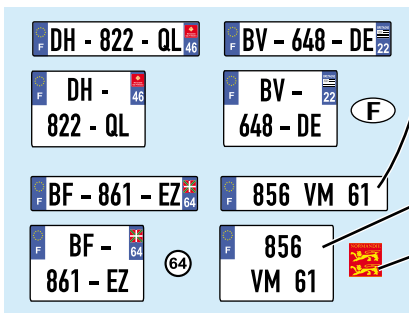
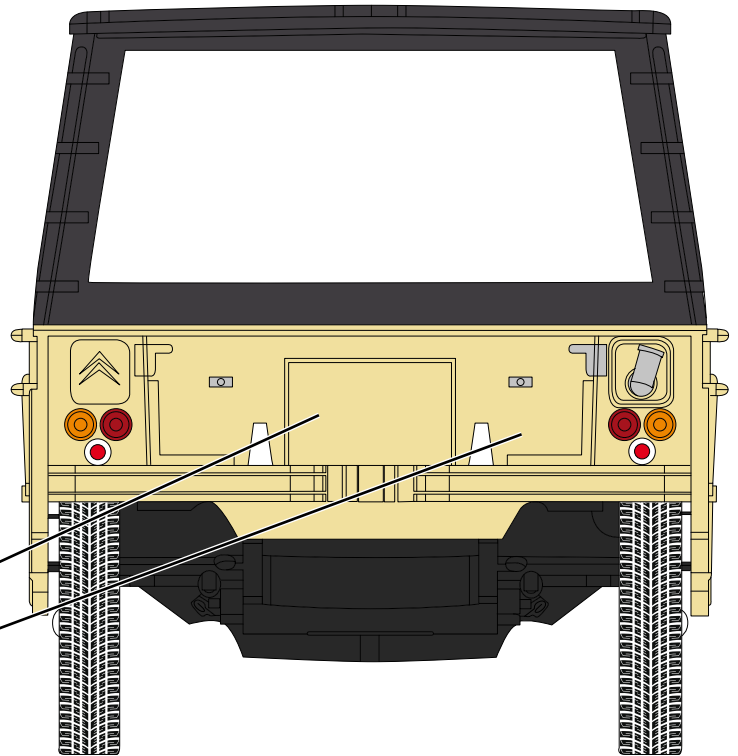
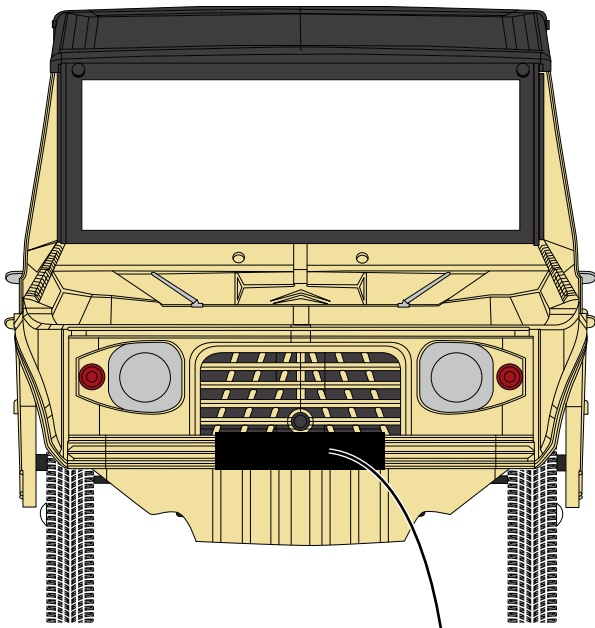

orange Kirghiz

1969 - 1987

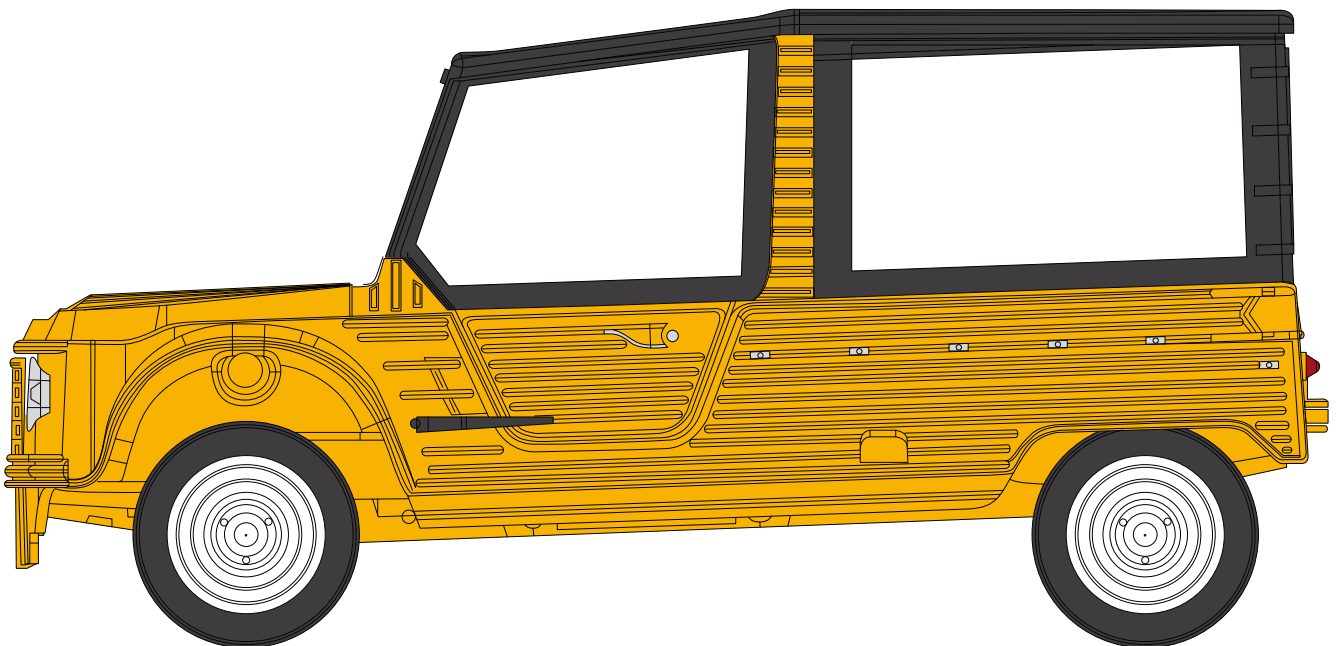
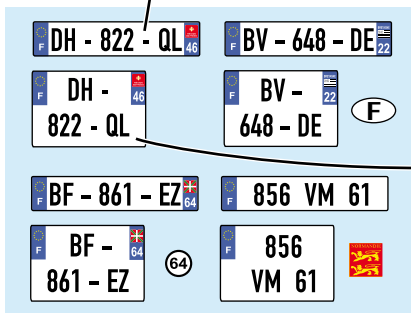
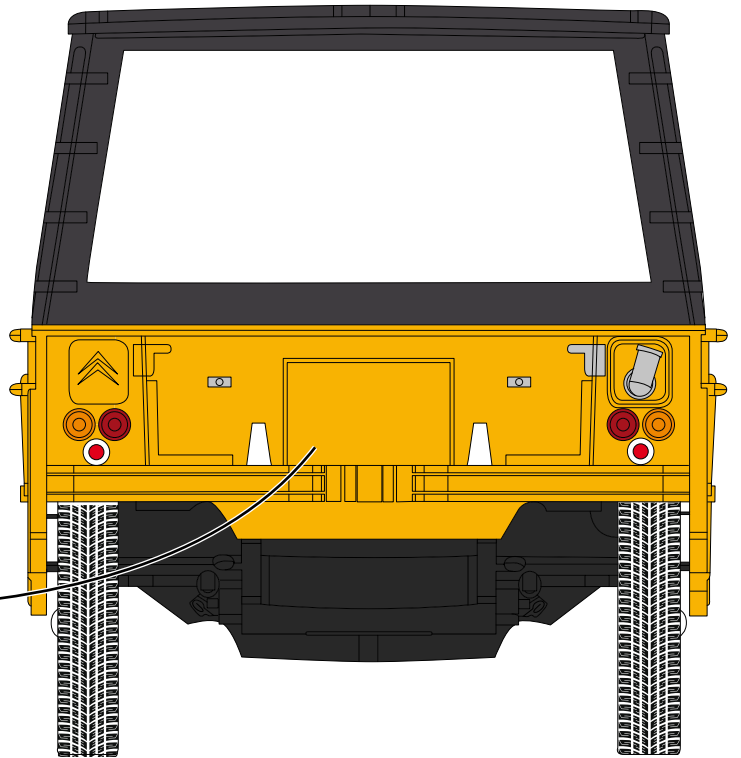
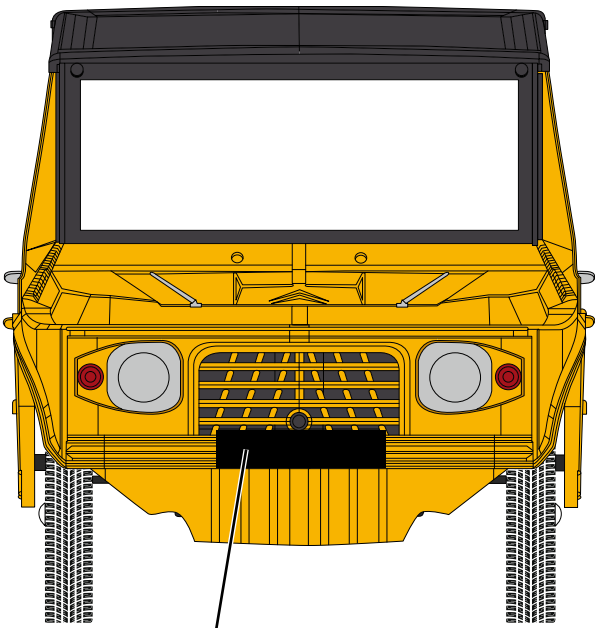

2	Numéro de phase Step number Schrittnummer Número de fase	56	Référence de couleur Colour reference no Farbangabe Referencia de color
37	Numéro de pièce Part number Teilenummer Número de pieza	6	Numéro de decal Decal number Nummer von Abziehbild Número de calcomanía

SERVICE CONSOMMATEURS 

www.heller.fr

Pour toute demande de SAV, connectez-vous sur notre site www.heller.fr puis envoyez votre demande détaillée via l'onglet «NOUS CONTACTER».

For any request of SAV(after-sales service), please connect on our website www.heller.fr then send us your detailed request via the « NOUS CONTACTER» tab.

HELLER HOBBY GmbH
Erlenbacher Str. 3
42477 - Radevormwald
GERMANY



Fabriqué en France