



# Pochoer<sup>®</sup>

Die-Cast Model Kits



HK122 - Porsche 917KH - Martini Edition

Instruction Manual



# Pocher

Die-Cast Model Kits

GB

Immerse yourself in the world of classic motorsport with the Pocher 1:8 Scale die-cast metal model kit of the Porsche 917KH – MARTINI Edition. This officially licensed model meticulously replicates the legendary car that triumphed at the 1971 Le Mans, driven by the renowned duo of Dutchman, Gijs van Lennep and Austrian, Helmut Marko.

This exceptional kit includes over 316 high-quality pre-decorated parts, complete with over 200 screws, allowing you to construct an incredibly detailed replica. The model faithfully features working suspension that accurately reflects the car's legendary handling and performance on the track. Additionally, it includes fully functional steering, moving doors, and a clamshell engine cover, providing an interactive building experience.

The MARTINI livery is authentically represented, showcasing the striking colours and design that made the Porsche 917KH an icon of endurance racing. Perfect for both seasoned model builders and collectors, this model kit offers a rewarding challenge that culminates in a stunning display piece.

Elevate your collection with the Pocher Porsche 917KH, a true celebration of automotive excellence. Experience the legacy of this remarkable vehicle and relive the excitement of Le Mans with this exquisite model kit.

I

Immergiti nel mondo dell'automobilismo classico con il kit in metallo pressofuso in scala 1:8 della Porsche 917KH – MARTINI Edition firmata Pocher. Questo modello con licenza ufficiale riproduce fedelmente l'auto leggendaria che trionfò a Le Mans nel 1971 guidata dal rinomato duo composto dall'olandese Gijs van Lennep e dall'austriaco Helmut Marko.

Questo kit straordinario include oltre 316 pezzi predecorati, completi di oltre 200 viti, per consentirti di realizzare una replica incredibilmente dettagliata. Il modello è dotato di sospensioni funzionanti che rispecchiano fedelmente la leggendaria maneggevolezza dell'auto e le sue prestazioni in pista. Inoltre è dotata di sterzo perfettamente funzionante, porte mobili e una copertura del motore a conchiglia, offrendo un'esperienza di costruzione interattiva.

La livrea MARTINI è rappresentata in modo autentico, mostrando i colori e il design accattivanti che hanno reso la Porsche 917KH un'icona delle gare di endurance. Perfetto sia per i modellisti esperti che per i collezionisti, questo kit offre una sfida gratificante che culmina in uno splendido pezzo da esposizione.

Valorizza la tua collezione con la Porsche 917KH di Pocher, un'autentica celebrazione dell'eccellenza automobilistica. Scopri l'eredità di questo straordinario veicolo e rivivi l'emozione di Le Mans con questo raffinato kit.

D

Tauchen Sie selbst in die Welt des klassischen Motorsports ein – mit dem Pocher Spritzguss-Modellbausatz im Maßstab 1:8 des Porsche 917KH – MARTINI Edition. Dieses offiziell lizenzierte Modell erfasst mit kompromissloser Detailgenauigkeit jenes legendär gewordene Auto, das im Le Mans Rennen 1971 mit dem renommierten Duo des Niederländers Gijs van Lennep und des Österreicher Helmut Marko am Steuer triumphierte.

Dieser außergewöhnliche Bausatz enthält über 316 vordekorierte Teile höchster Qualität, zusammen mit über 200 Schrauben. Sie können damit ein in jeder Hinsicht originalgetreues Modell zusammenstellen. Seine bewegliche Aufhängemechanik reflektiert das legendäre Fahrverhalten und Leistungsvermögen des Autos auf dem Asphalt. Dazu noch bietet es komplette Lenkfunktion, bewegliche Türen wie auch eine Clamshell-Motorhaube und ermöglicht ein interaktives Bauerlebnis.

Die MARTINI-Rennlackierung ist wirklicheitsgetreu nachgebildet. Sie stellt die kontrastierenden Farben und die markante Formgebung des Porsche 917KH heraus, einer Ikone des Endurance-Rennfahrens. Perfekt für passionierte Modellbauer wie auch Sammler konzipiert, bietet dieser Modellbausatz eine lohnende Herausforderung, die mit der Schaffung eines beeindruckenden Schaustücks begeistert.

Bereichern Sie Ihre Sammlung mit dem Pocher Porsche 917KH, einem freudebringenden Ergebnis automobiltechnischer Exzellenz. Erleben Sie das Erbe dieses bemerkenswerten Fahrzeugs und das prickelnde Gefühl von Le Mans mit diesem exquisiten Modellbausatz.

F

Plongez dans le monde du sport automobile classique avec le modèle réduit en métal moulé à l'échelle 1:8 de la Porsche 917KH – Édition MARTINI. Ce modèle sous licence officielle reproduit méticuleusement la voiture légendaire qui a triomphé au Mans en 1971 aux mains du célèbre duo composé du Néerlandais Gijs van Lennep et de l'Autrichien Helmut Marko.

Ce kit exceptionnel comprend plus de 316 pièces prédecorées de haute qualité, accompagnées de plus de 200 vis, pour vous permettre de construire une réplique incroyablement détaillée. Ce modèle réduit est doté d'une suspension fonctionnelle qui reflète fidèlement la tenue de route et les performances légendaires de la voiture sur circuit. En outre, il comprend une direction entièrement fonctionnelle, des portes ouvrantes et un capot moteur articulé, offrant ainsi une expérience de construction interactive.

La livrée MARTINI est représentée de manière authentique, mettant en valeur les couleurs et le design qui ont fait de la Porsche 917KH une icône de la course d'endurance. Idéal pour les modélistes chevronnés et les collectionneurs, ce kit de modélisme constitue un défi gratifiant aboutissant à une superbe pièce d'exposition.

Enrichissez votre collection avec la Porsche 917KH de Pocher, une véritable célébration de l'excellence automobile. Découvrez l'héritage de ce véhicule remarquable et revivez la passion du Mans avec cet kit de modélisme d'un raffinement exceptionnel.

E

Sumérgete en el automovilismo clásico con la maqueta diecast del Porsche 917KH – Edición MARTINI a escala 1:8 de Pocher. Este modelo con licencia oficial recrea con total precisión el legendario coche que se consagró en Le Mans 1971, pilotado por el destacado dúo Gijs van Lennep y Helmut Marko.

Este impresionante kit incluye más de 316 piezas de alta calidad, ya decoradas, y más de 200 tornillos, lo que te permitirá ensamblar una réplica increíblemente detallada y realista. El modelo cuenta con una suspensión funcional que refleja fielmente el manejo y rendimiento legendarios del coche en la pista. Además, incluye dirección totalmente funcional, puertas móviles y una cubierta del motor abatible, ofreciendo una experiencia de montaje interactiva.

La decoración MARTINI se recrea con absoluta fidelidad, resaltando los colores y el diseño que convirtieron al Porsche 917KH en un verdadero ícono de las carreras de resistencia.

Ideal tanto para modelistas expertos como para coleccionistas, este kit ofrece un desafío gratificante que culmina en una espectacular pieza de exhibición.

Lleva tu colección al siguiente nivel con el Pocher Porsche 917KH, un auténtico tributo a la excelencia automovilística. Revive el legado de este vehículo extraordinario y experimenta la emoción de Le Mans con esta exclusiva maqueta a escala.

中文

Pocher 1:8 比例压铸金属模型套件 · 带您重温经典赛车传奇 · 完美复刻 Porsche 917KH——MARTINI 版。这款官方授权的模型精确复刻了 1971 年勒芒赛事中由荷兰车手 Gijs van Lennep 和奥地利车手 Helmut Marko 驾驶的传奇赛车。

这款非凡的套件包含超过 316 个高品质的预装饰部件 · 以及 200 多颗螺丝 · 让您能够精心拼装出一款极度逼真的赛车模型。模型精准复现了功能性悬挂系统 · 完美展现了赛车在赛道上传奇般的操控性和性能。此外 · 还配备了全功能转向系统 · 可动式车门和蚌壳式发动机盖 · 为您带来极致的互动式组装体验。

MARTINI 涂装在此模型上得到了忠实还原 · 其鲜明的色彩和设计让 Porsche 917KH 成为了耐力赛的传奇象征。无论您是经验丰富的模型制作者还是收藏家 · 这款模型套件都能为您提供一个充满成就感的挑战 · 并最终呈现出一件令人惊叹的展示品。

拥有 Pocher Porsche 917 KH · 不仅能让您的收藏品更加丰富 · 也能使您从心底向经典致敬。透过这款精美的模型套件 · 您将领略这款非凡赛车的传奇历史 · 重温勒芒赛事的澎湃激情。

日本

ポッシャー製 1:8スケールの精密ダイキャスト金属製模型キット、ポルシェ 917KH – MARTINI エディションで、クラシックなモータースポーツの世界に没入してください。公式ライセンスを受けたこの模型は、1971年のル・マン24時間レースで優勝した伝説の一台を緻密に再現しています。オランダの英雄ジス・ヴァン・レンプとオーストリアのヘルムート・マルコという名高いコンビが操ったこの車は、モータースポーツ史に輝く存在です。

この極上のキットには、316点以上の高精度な塗装済みパーツと200個以上のネジが付属しており、精巧なレプリカを組み立てることができます。このモデルは、実車の伝説的なハンドリングと走行性能を忠実に再現した可動式サスペンションを備えています。さらに、可動式ステアリング、開閉式ドア、クラムシェル式エンジンカバーを搭載しており、実践的な組立体験を提供します。

MARTINIのリバリーが完璧に再現され、ポルシェ 917KHを耐久レースの象徴たらしめた印象的なデザインとカラースキームが見事に表現されています。このキットは、熟練の模型製作者や収集家にとって理想的なチャレンジとなり、完成後は見事な展示作品としてその価値を発揮します。

ポッシャー製ポルシェ 917KHでコレクションの格を上げてください。自動車技術の粋を結集した逸品です。この精緻なモデルキットで、伝説的な名車の遺産に触れ、ル・マン24時間レースの感動を再体験してください。

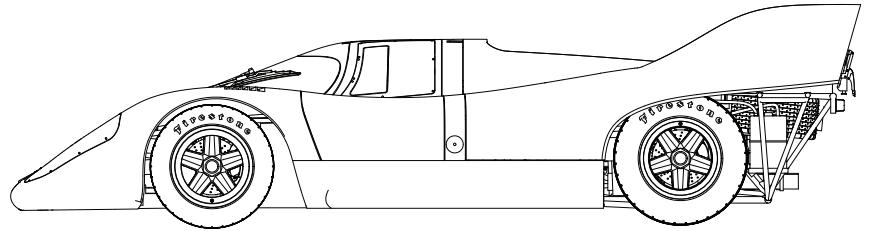
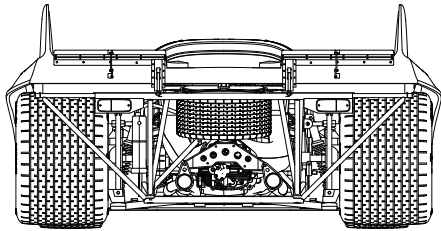
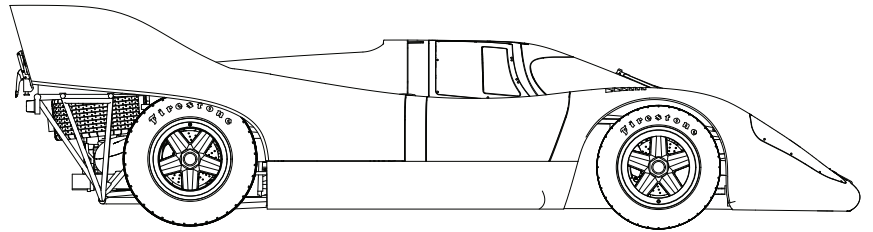
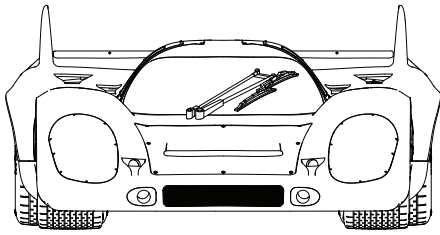

### Assembly icon instructions

Assembly phase  
Fase di montaggio  
Montagephase  
Phase de montage  
Fase de montaje  
組立工程  
装配阶段

Assembled group  
Gruppo assemblato  
Versammelten gruppe  
Groupo assemblé  
Groupo montado  
組立グループ  
装配組

Pay attention  
Prestare attenzione  
Achtung  
Attention  
Prestar atención  
注意して  
注意

Tube  
Tubo  
Rohr  
Tube  
Tubo  
チューブ  
管

Glue  
Colla  
Kleber  
Colle  
Pegamento  
接着剂  
胶水

Information  
Informazione  
Information  
Information  
Información  
情報  
信息



Assembly order  
Ordine de montaggio  
Die Ordnung der montage  
Ordre d'assemblage  
Orden de montaje  
組み付け順  
装配顺序

Sprue part number  
Número del pezzo  
Sprue Teilnummer  
Numéro de pièce  
Número de pieza  
部品番号  
零件编号

Water decal  
Decalcomanie  
Decals  
Decalcomanies  
Calmonía  
デカール  
贴花

Screwed  
Avvitare  
Festschrauben  
Visser  
Atornillar  
ビス  
拧紧

Pin  
Spilla  
Stift  
Épingler  
Anclar  
ダウエ  
金属销

Assembled view  
Vista assemblata  
Zusammengebaute Ansicht  
Vue assemblée  
Vista ensamblada  
組み立て図  
装配视图



 1.5X5 PM	 2.3X5 PB	 1.5X7 PM	 1.5X4 PM	 2.0X4 PM	 2.3x4 PM	 2.0x5 PM
 1.5X4 PB	 2.0X6 PM	 2.0X3 PWM	 2.3X4 PWB	 2.3X4 PB	 2.3x3 PWM	 2.3X5 PWM
 M6X35 PM	 2.0x7	 2.0X8	 2.0X9			



1

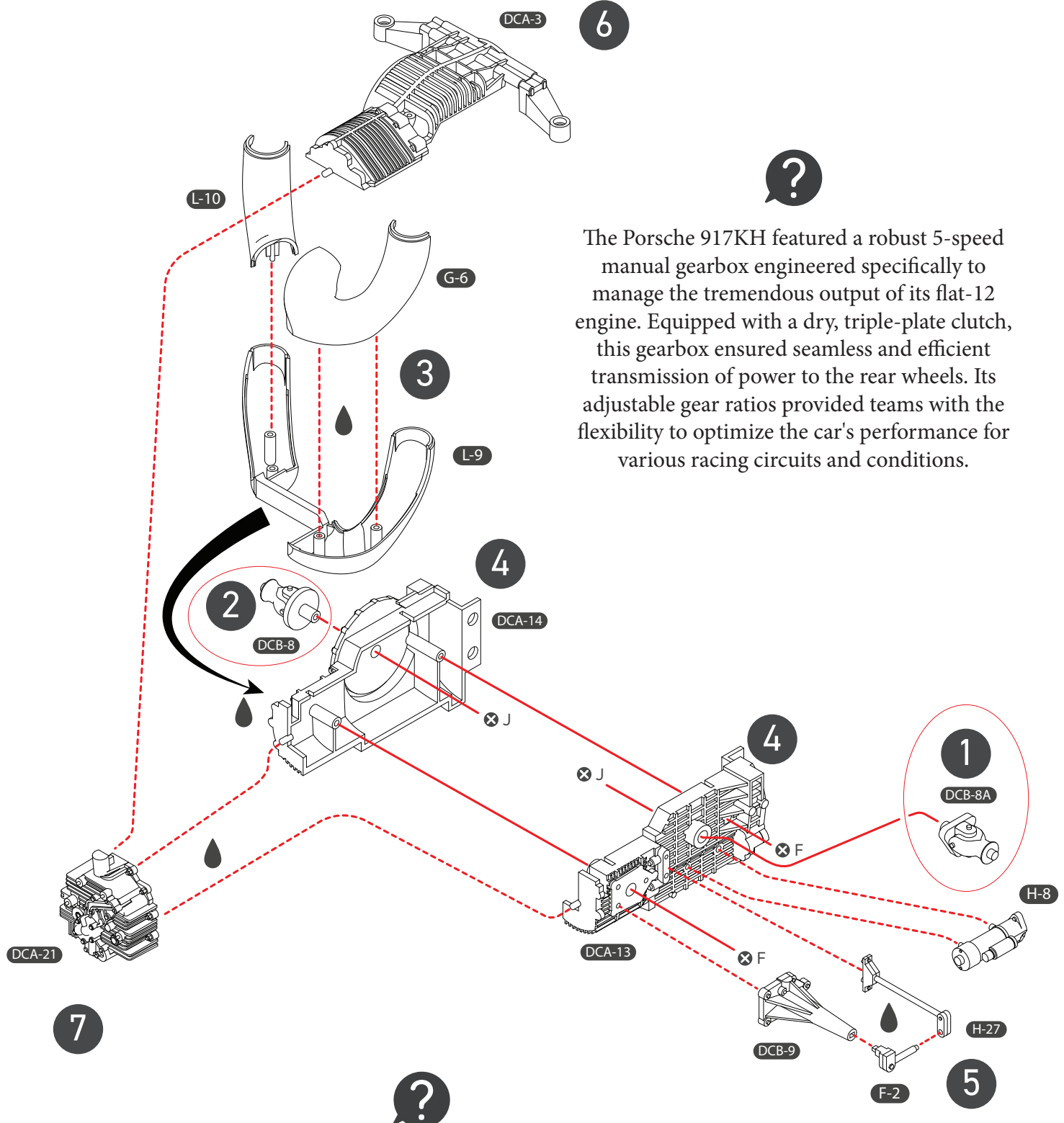

The Porsche 917KH featured a robust 5-speed manual gearbox engineered specifically to manage the tremendous output of its flat-12 engine. Equipped with a dry, triple-plate clutch, this gearbox ensured seamless and efficient transmission of power to the rear wheels. Its adjustable gear ratios provided teams with the flexibility to optimize the car's performance for various racing circuits and conditions.

Designed for endurance racing, the gearbox prioritised both reliability and precision. Its lightweight and compact structure aligned perfectly with the car's overarching design ethos, emphasising high performance and engineering excellence.

SCREW F = 2  
SCREW J = 2

2

A#1

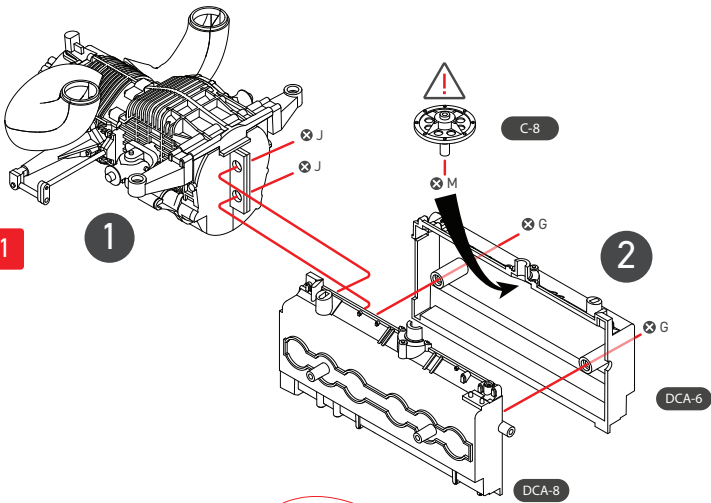

Carefully screw 360° and then unscrew 180° and repeat to remove metal swarf and reduce stress on screws

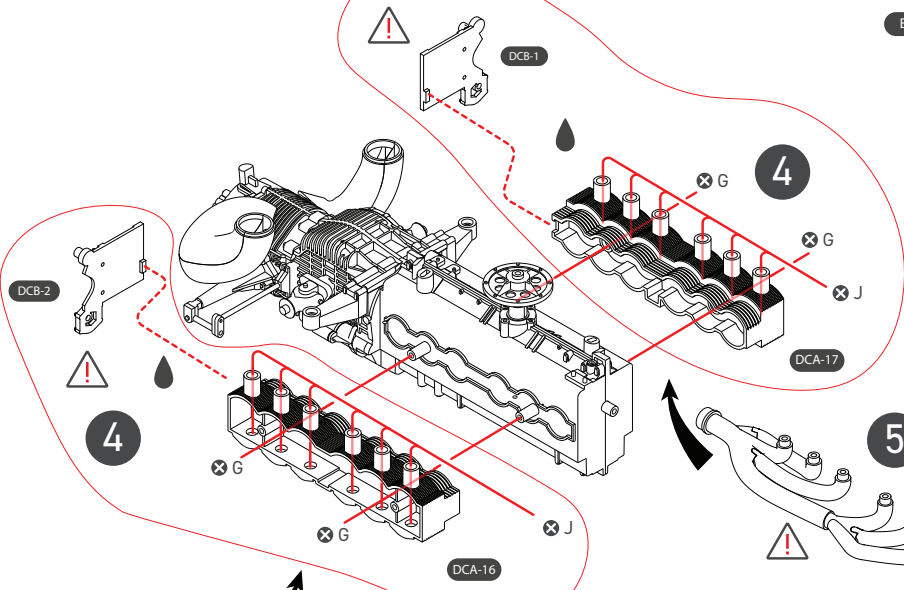
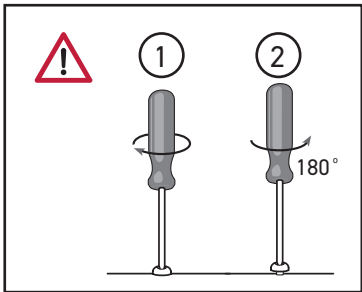

A#3

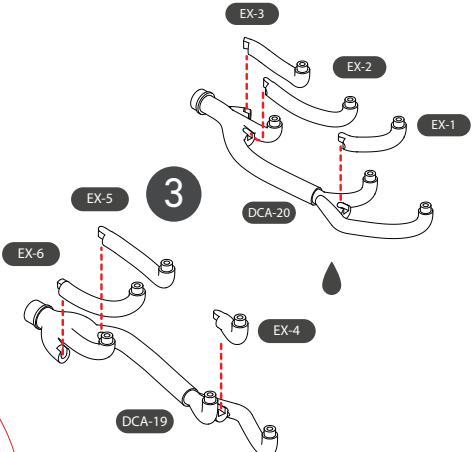

A#2

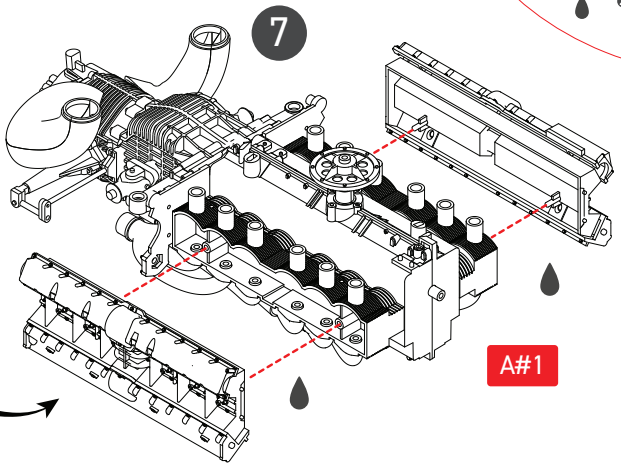
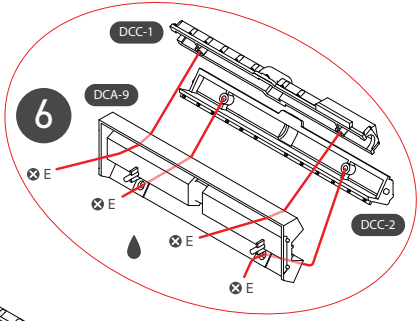
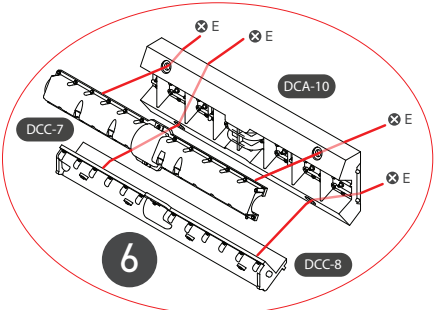

A#1

- SCREW E = 8
- SCREW G = 6
- SCREW J = 14
- SCREW M = 1



3



Red dashed lines indicate that parts should be glued, solid red lines should be screwed together.

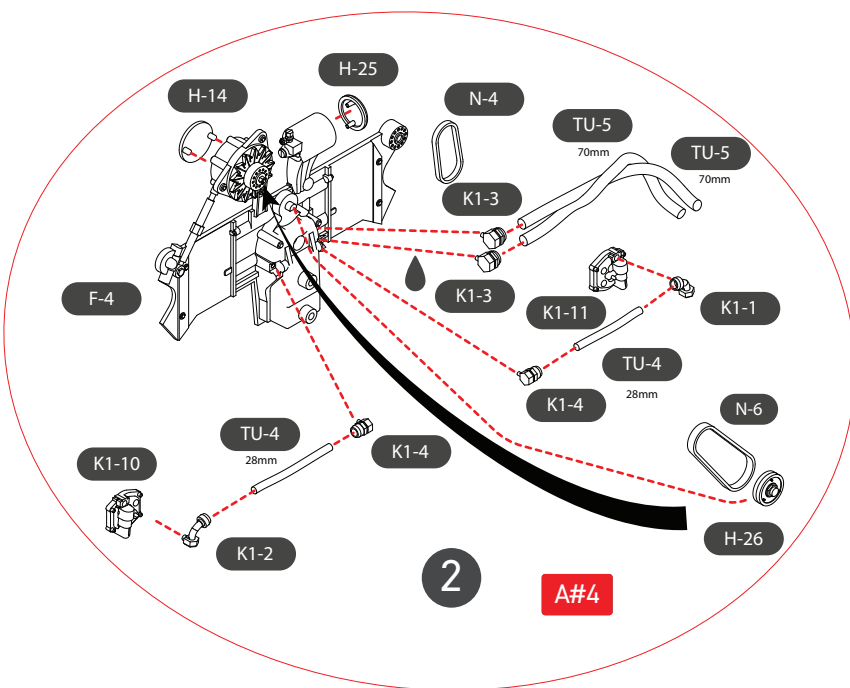
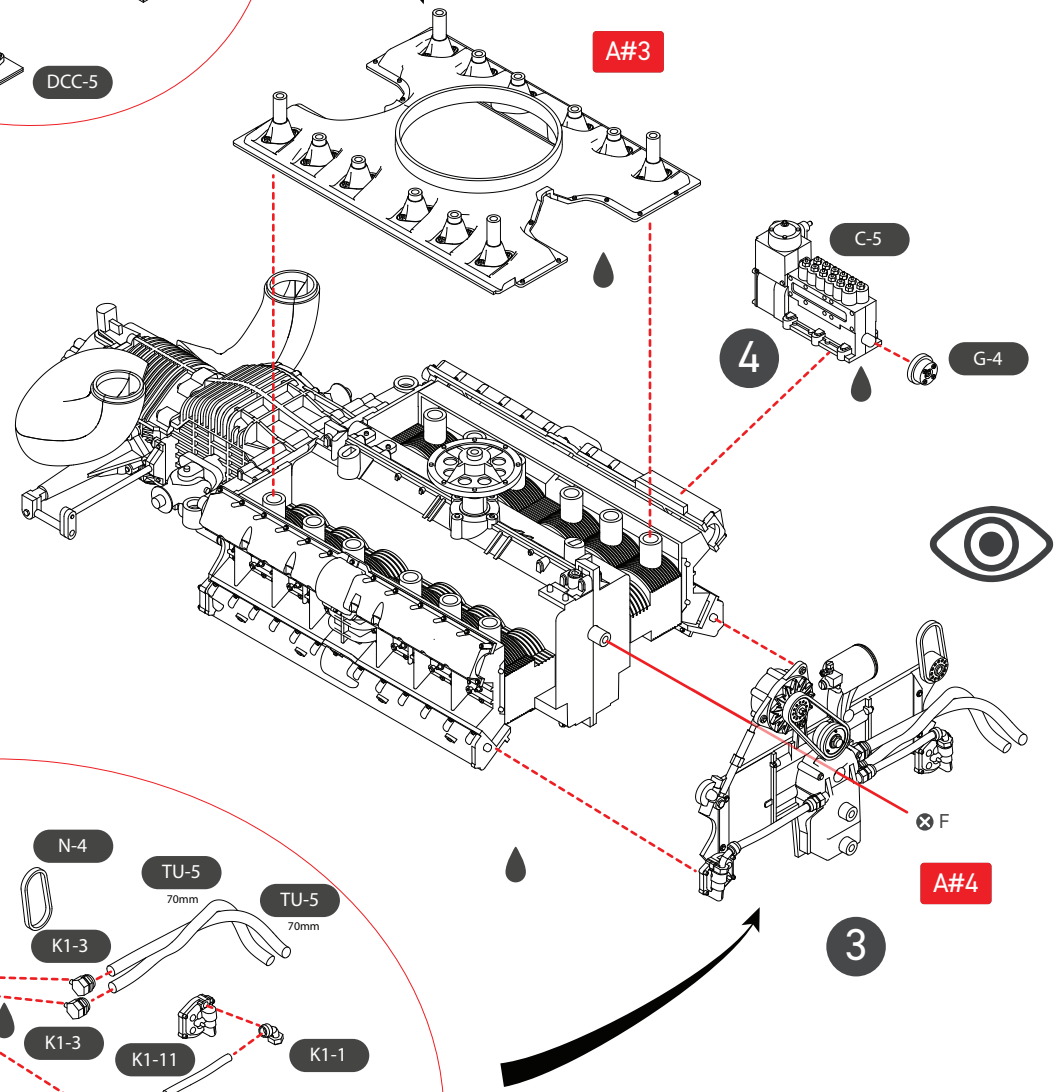
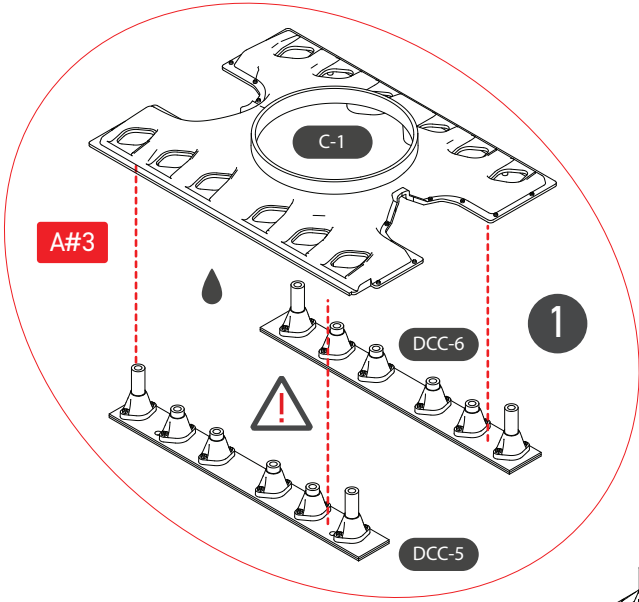

SCREW F = 1

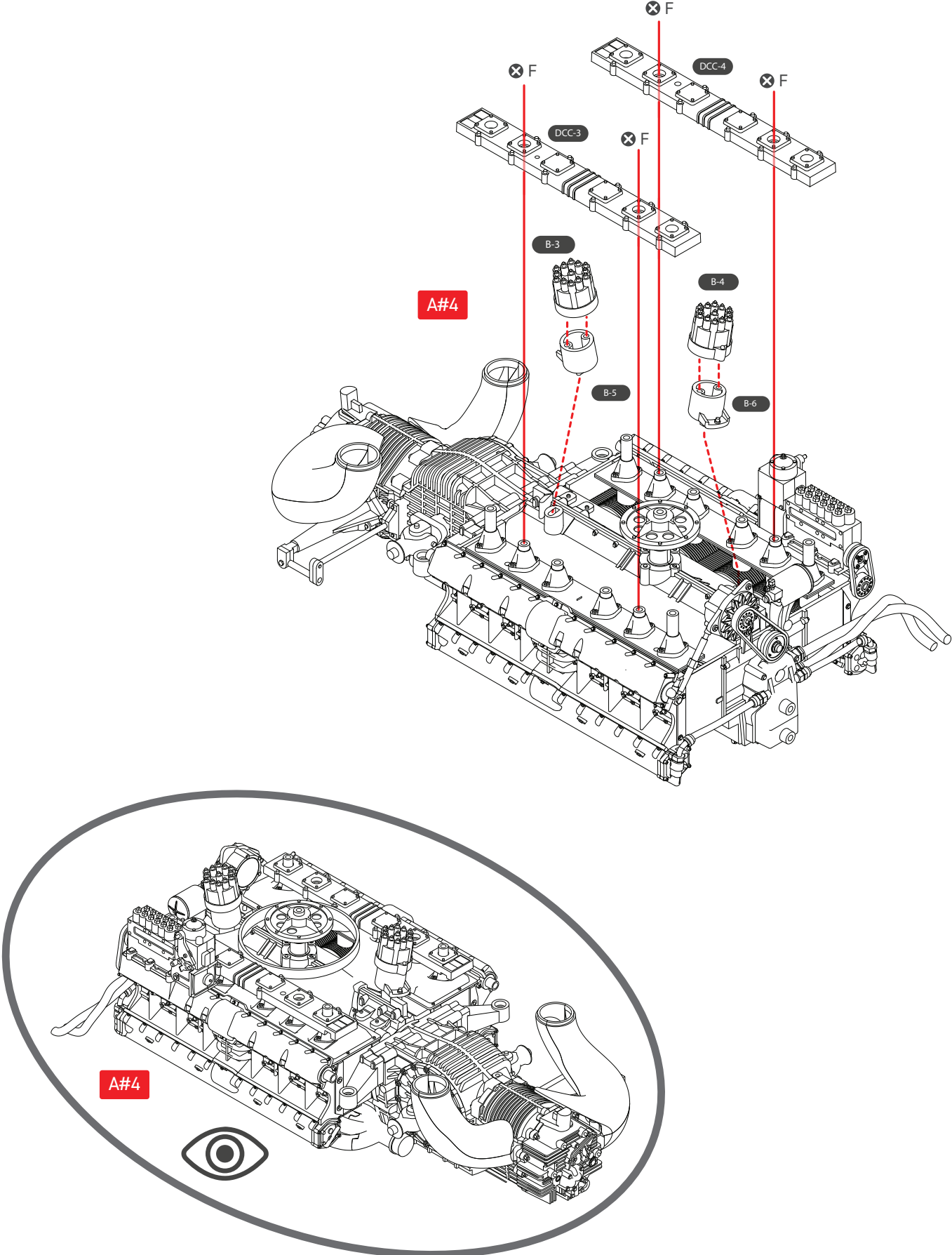

SCREW F = 4



- 1 TU-2 110mm x2
- 2 TU-2 110mm x2
- 3 TU-2 102mm x2
- 4 TU-2 97mm x2
- 5 TU-2 103mm x2
- 6 TU-2 96mm x2
- 7 TU-2 92mm x2
- 8 TU-2 102mm x2
- 9 TU-2 104mm x2
- 10 TU-2 111mm x2
- 11 TU-2 120mm x2
- 12 TU-2 120mm x2

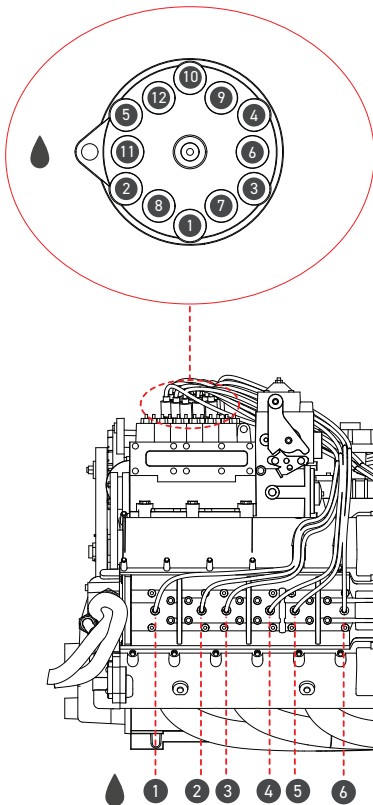
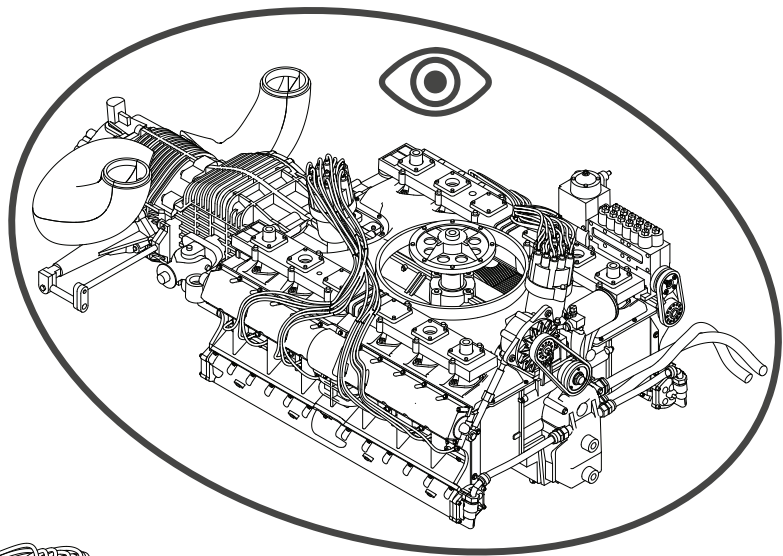
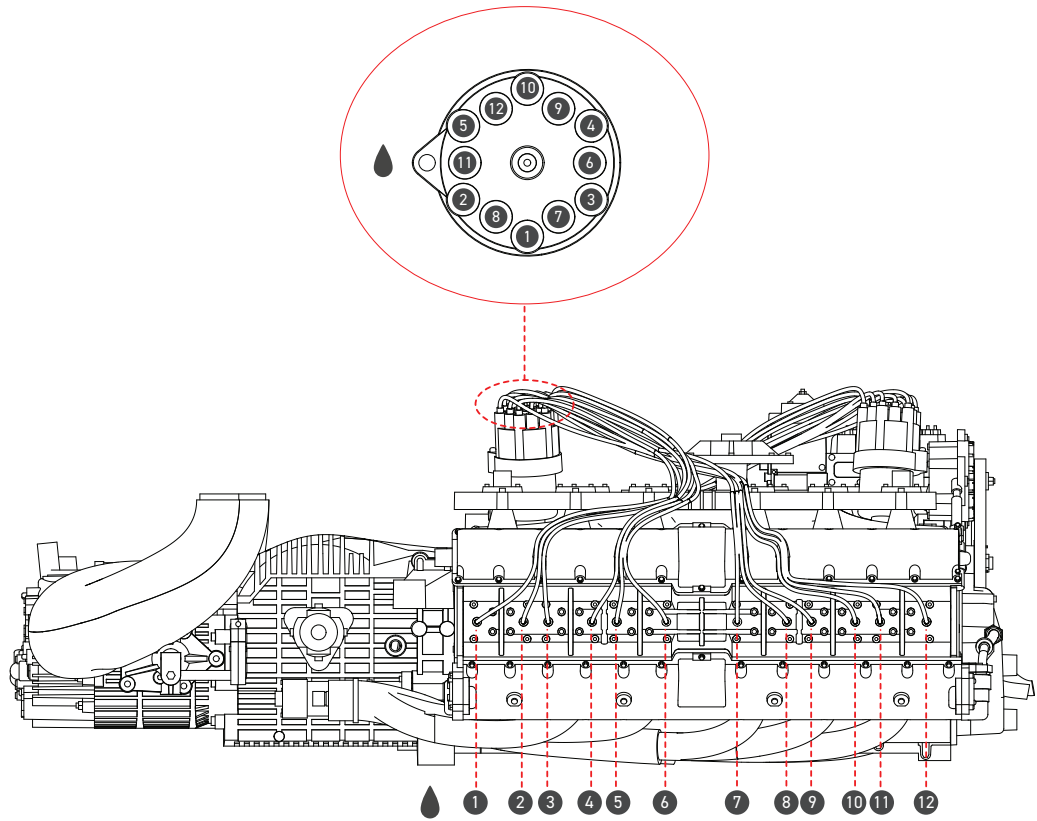

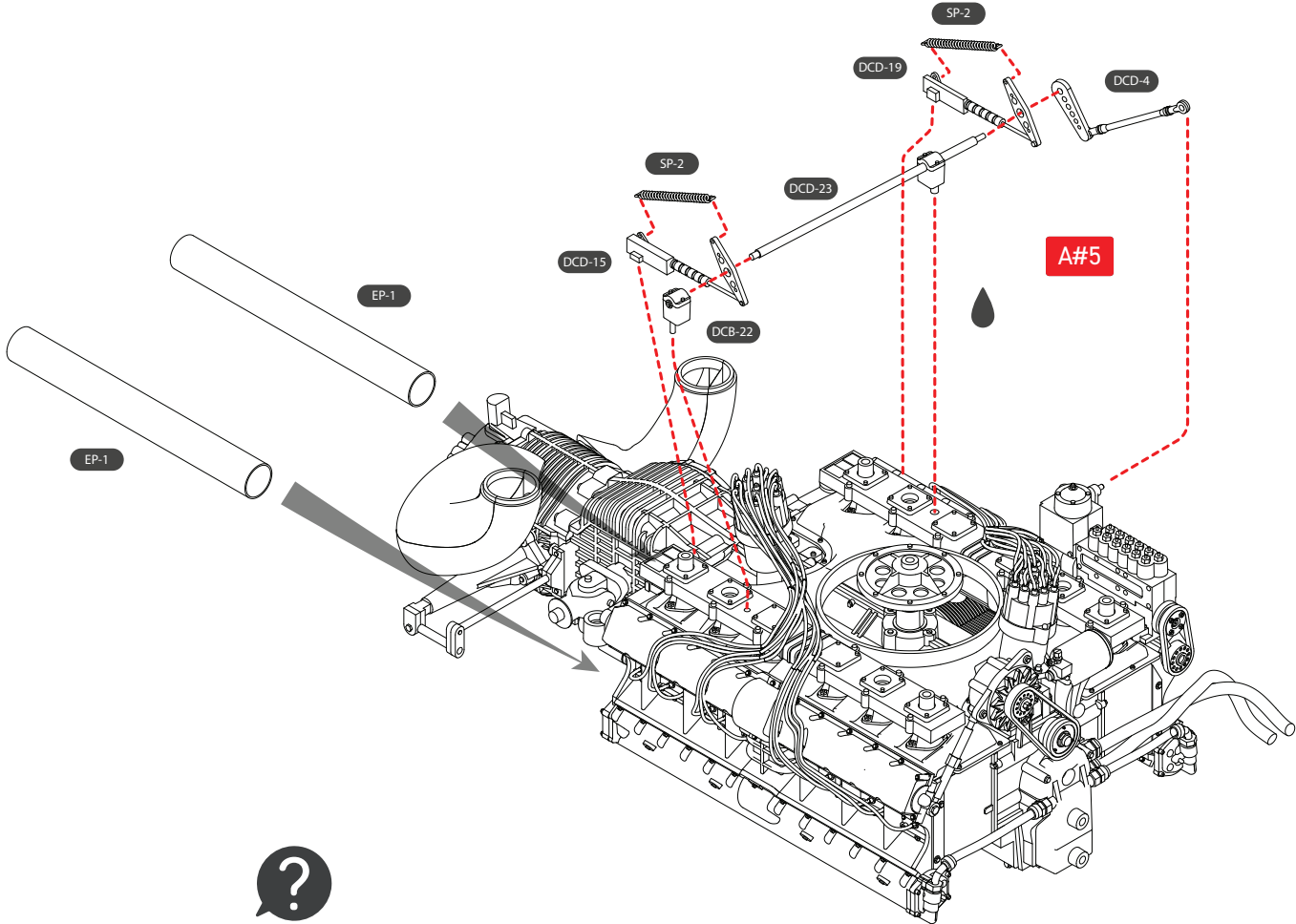

The engineering of the Porsche 917KH is a marvel of innovation and precision. Its flat-12 engine, with a displacement of 4.9 liters, was air-cooled and capable of producing an impressive 620 horsepower at 8,400 RPM.

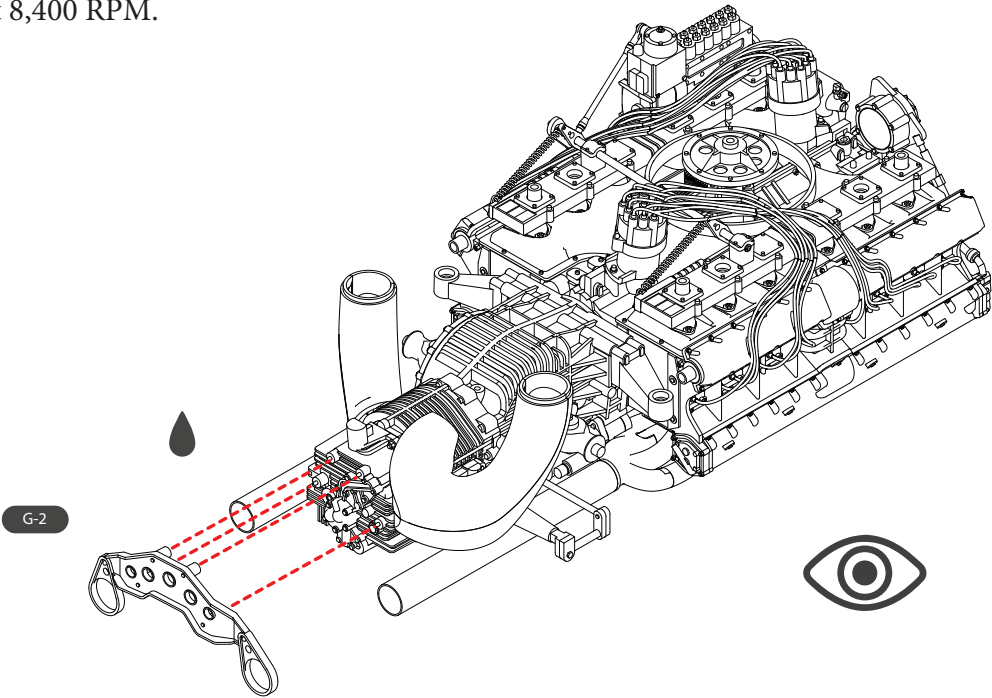





The DC-3 and DC-18 components fit snugly and are designed to slot into positioning holes that are situated close together. Ensure you carefully align and insert them into the correct holes to avoid any errors.

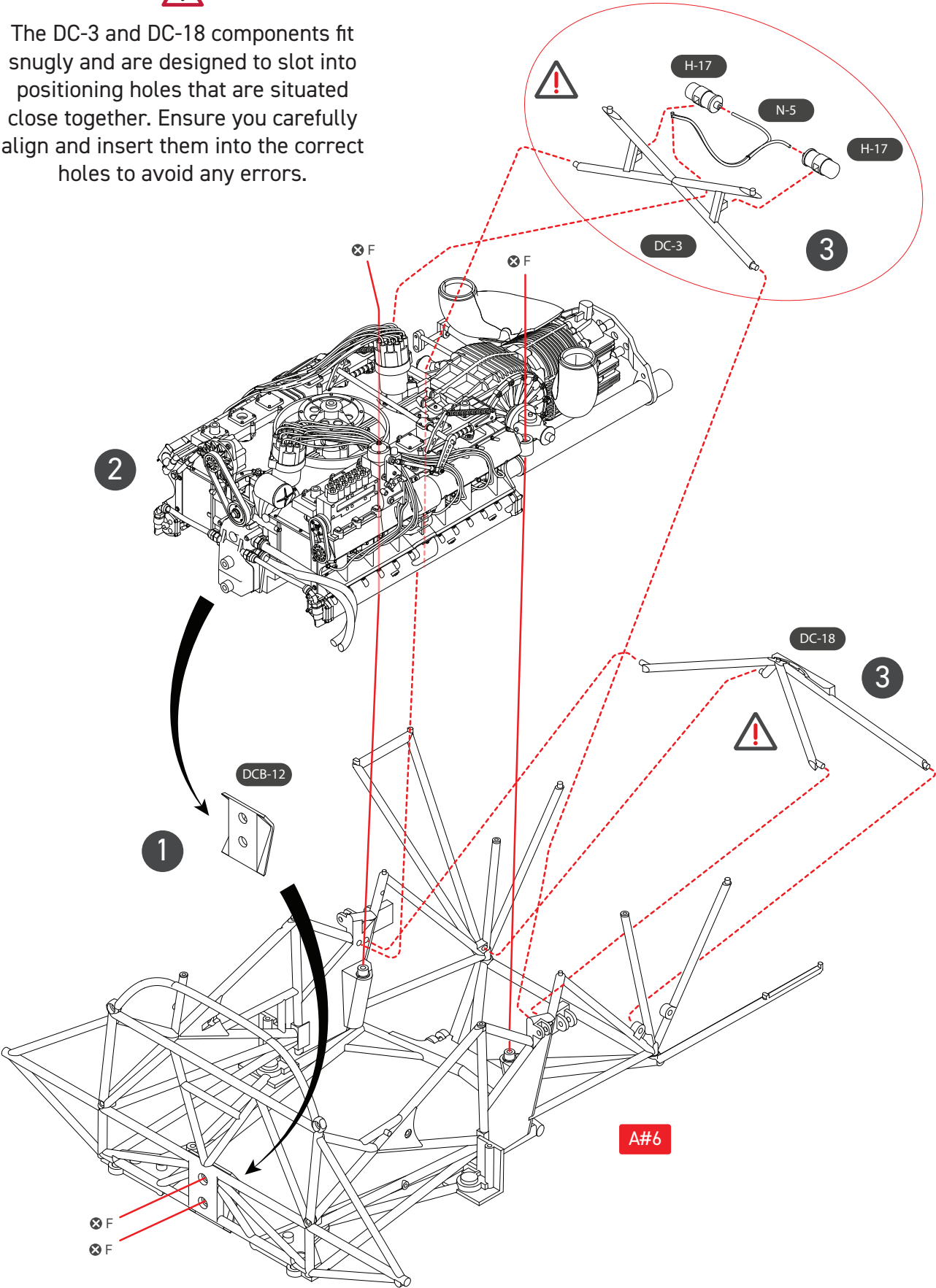

SCREW F = 4

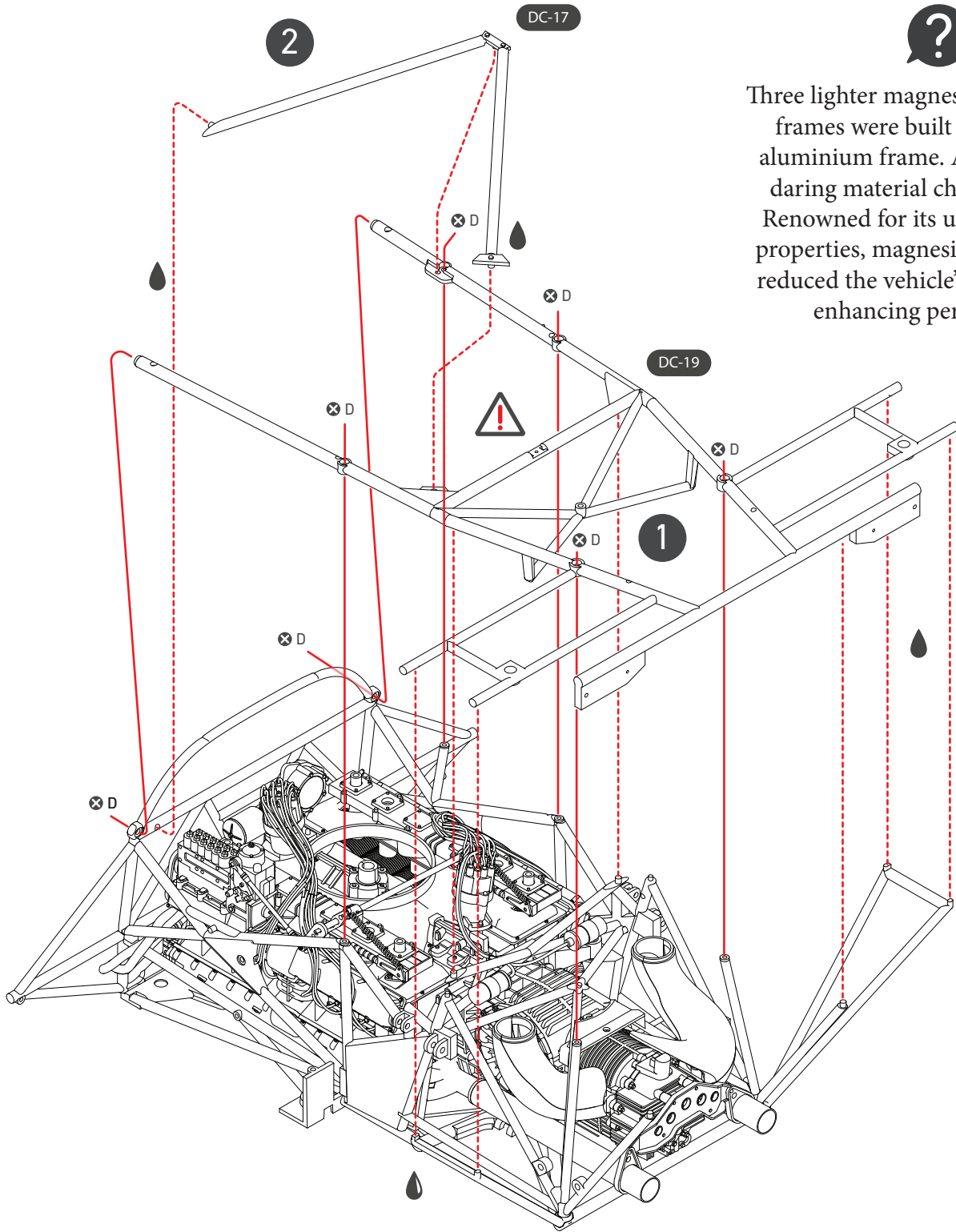

Three lighter magnesium grid tubular frames were built in place of the aluminium frame. An inventive yet daring material choice for its era. Renowned for its ultra-lightweight properties, magnesium significantly reduced the vehicle's overall weight, enhancing performance.

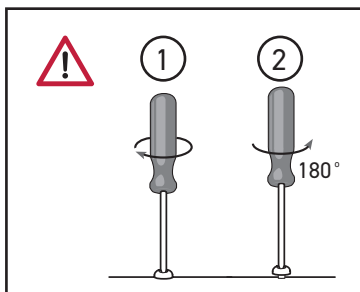

Carefully screw 360° and then unscrew 180° and repeat to remove metal swarf and reduce stress on screws.

SCREW D = 7

5

1

WD-3

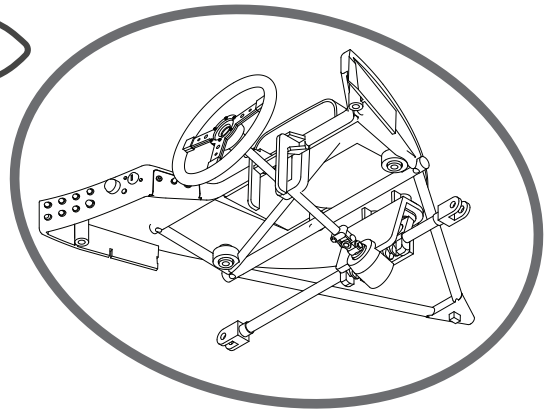
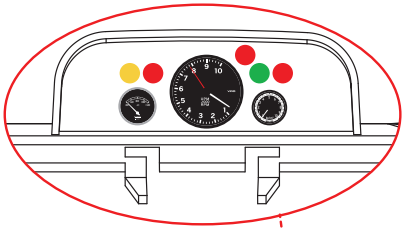

2

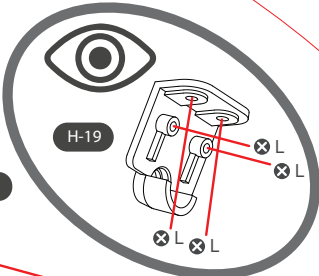

F-1

H-19



A#7

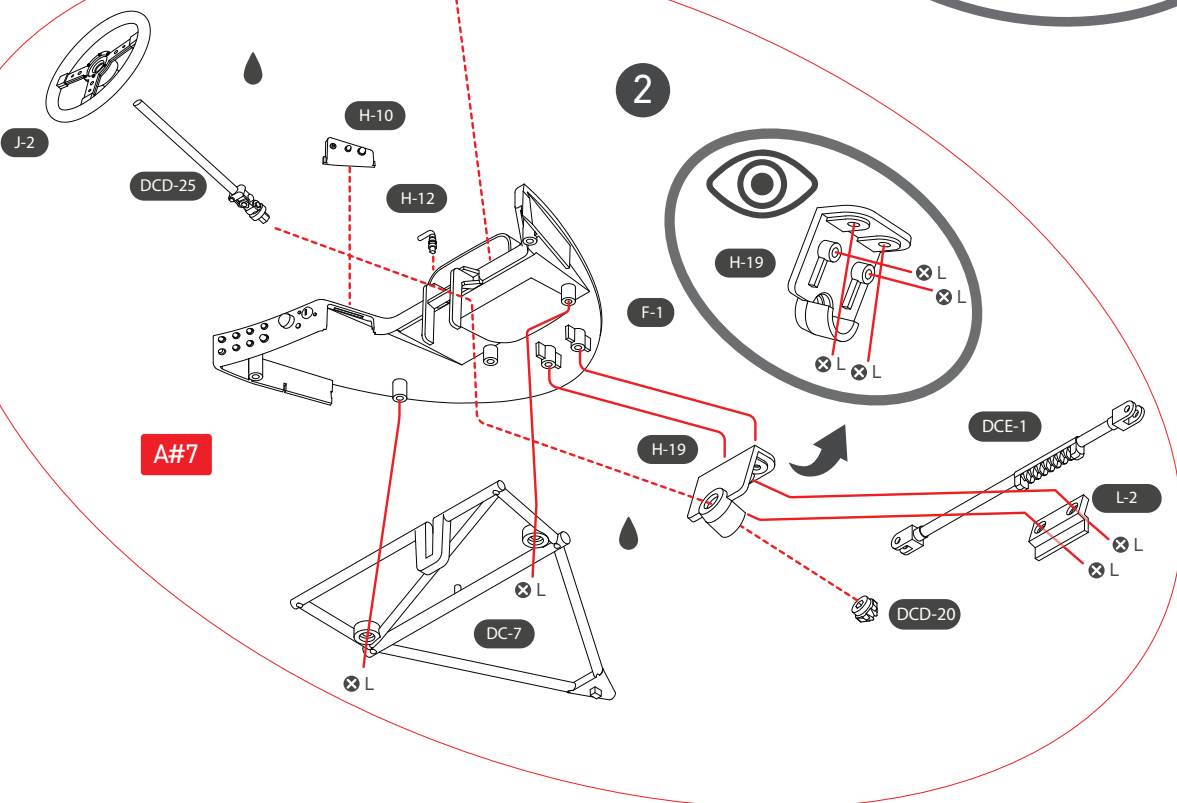

6

3

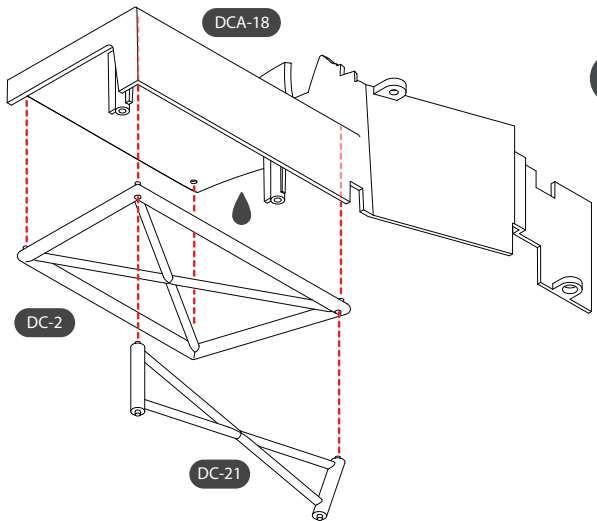

DCA-18

DC-2

DC-21

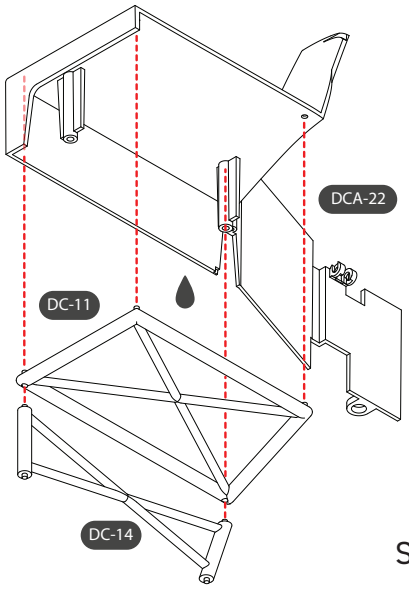

DCA-22

DC-11

DC-14

SCREW L = 6

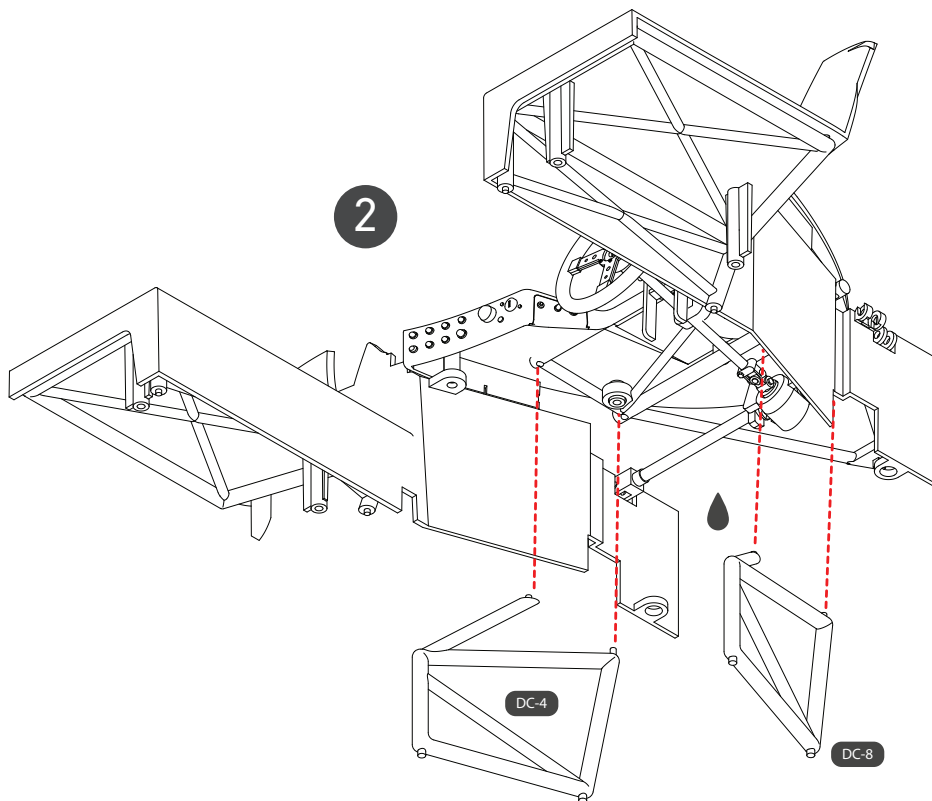
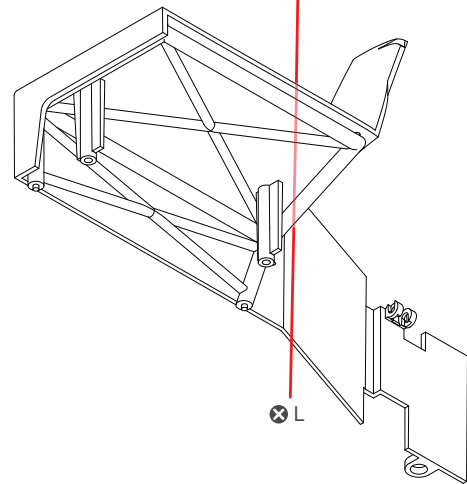
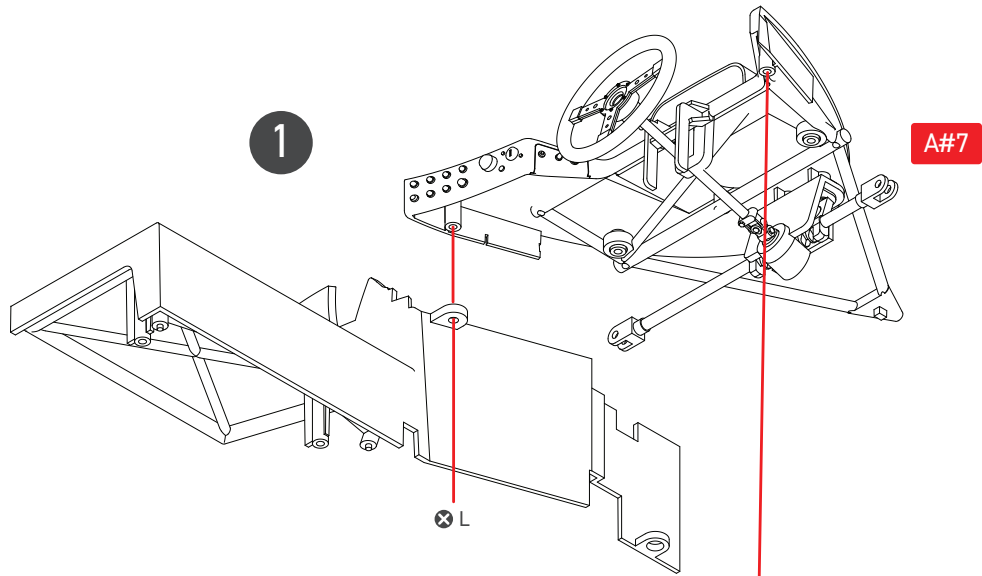

SCREW L = 2

7

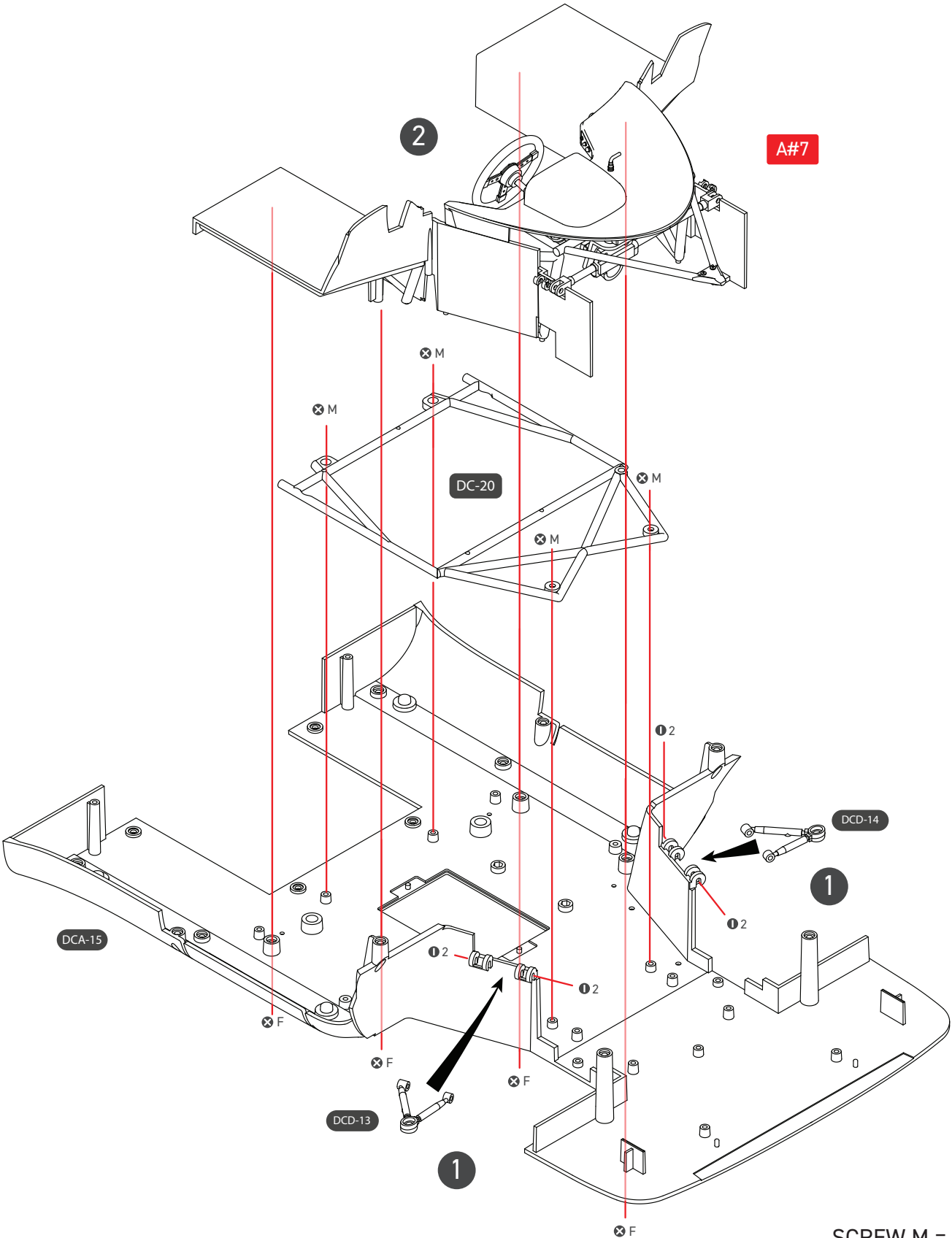

A#7

2

DC-20

DCD-14

DCA-15

DCD-13

1

1

SCREW M = 4  
 SCREW F = 4  
 PIN 2 = 4



8



Glue SP-1 into K-1 first to stop these from moving whilst building pedal assembly

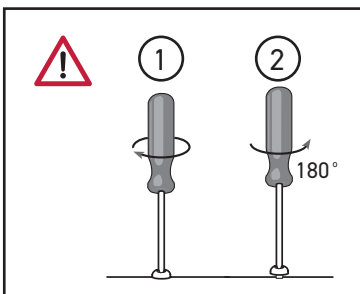
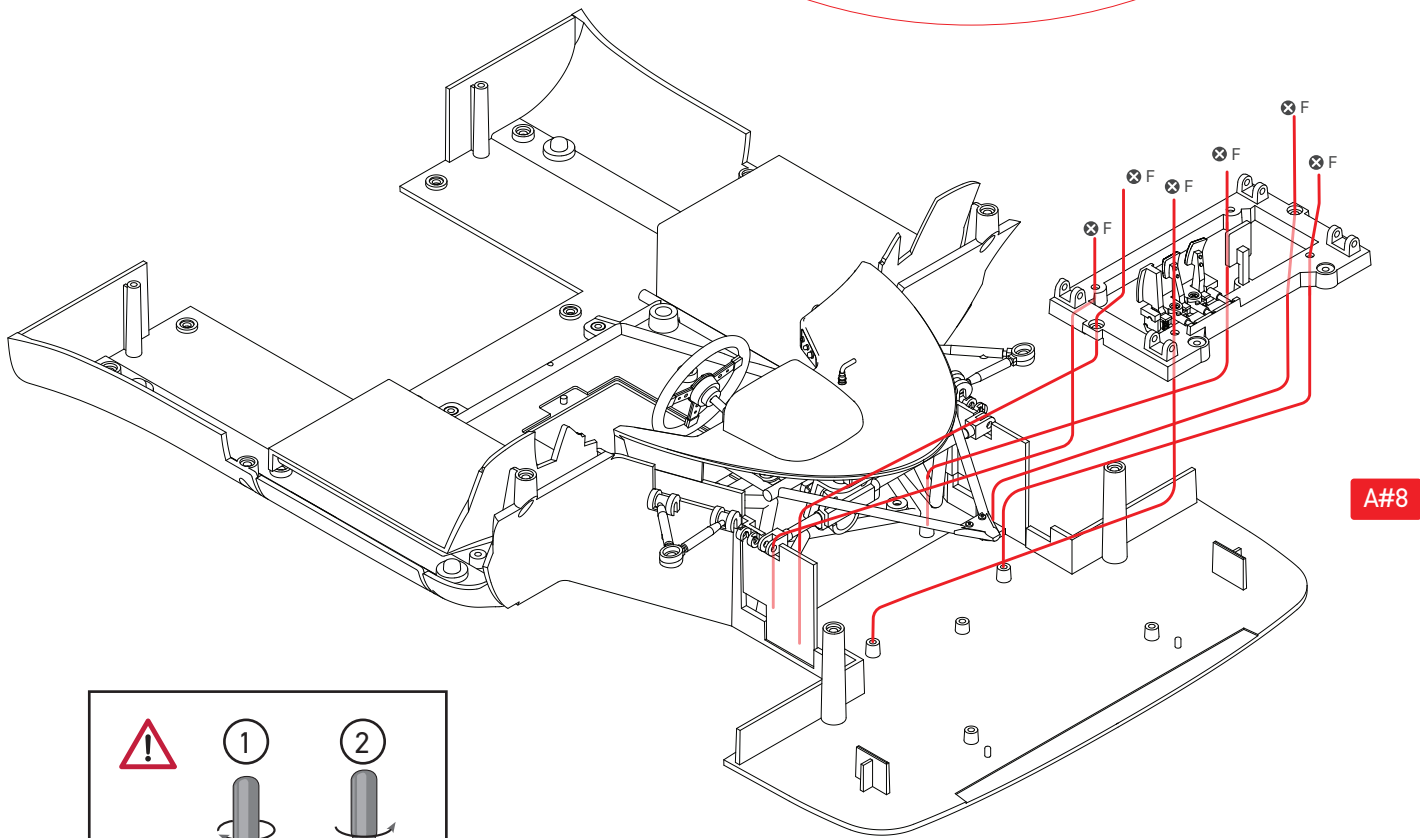
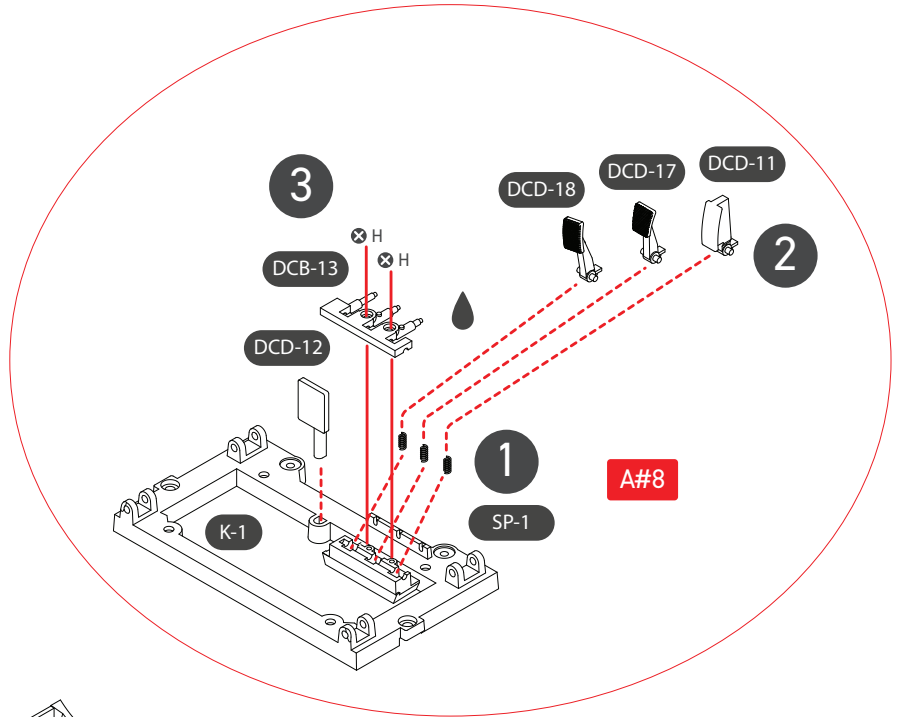

Carefully screw 360° and then unscrew 180° and repeat to remove metal swarf and reduce stress on screws

SCREW F = 6  
SCREW H = 2

9

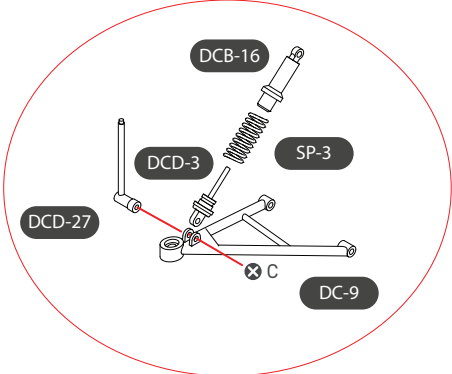
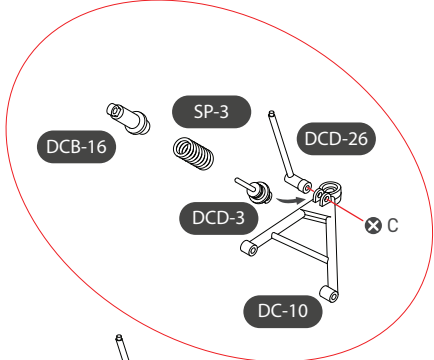
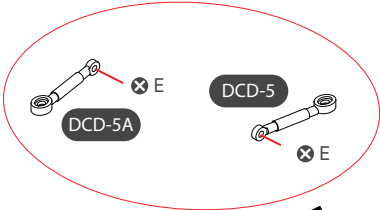
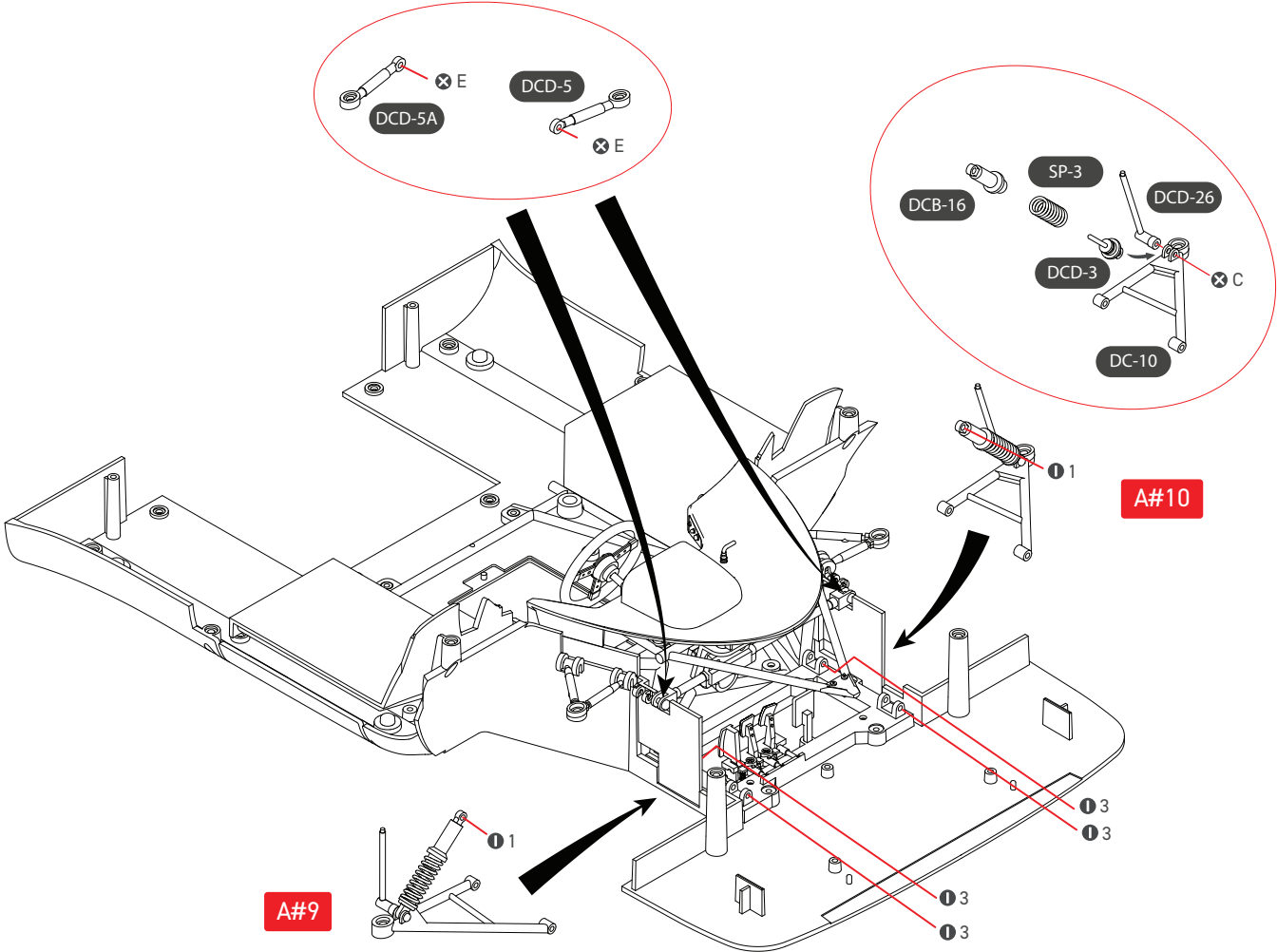

SCREW C = 2  
 SCREW E = 2  
 PIN 1 = 2  
 PIN 3 = 4

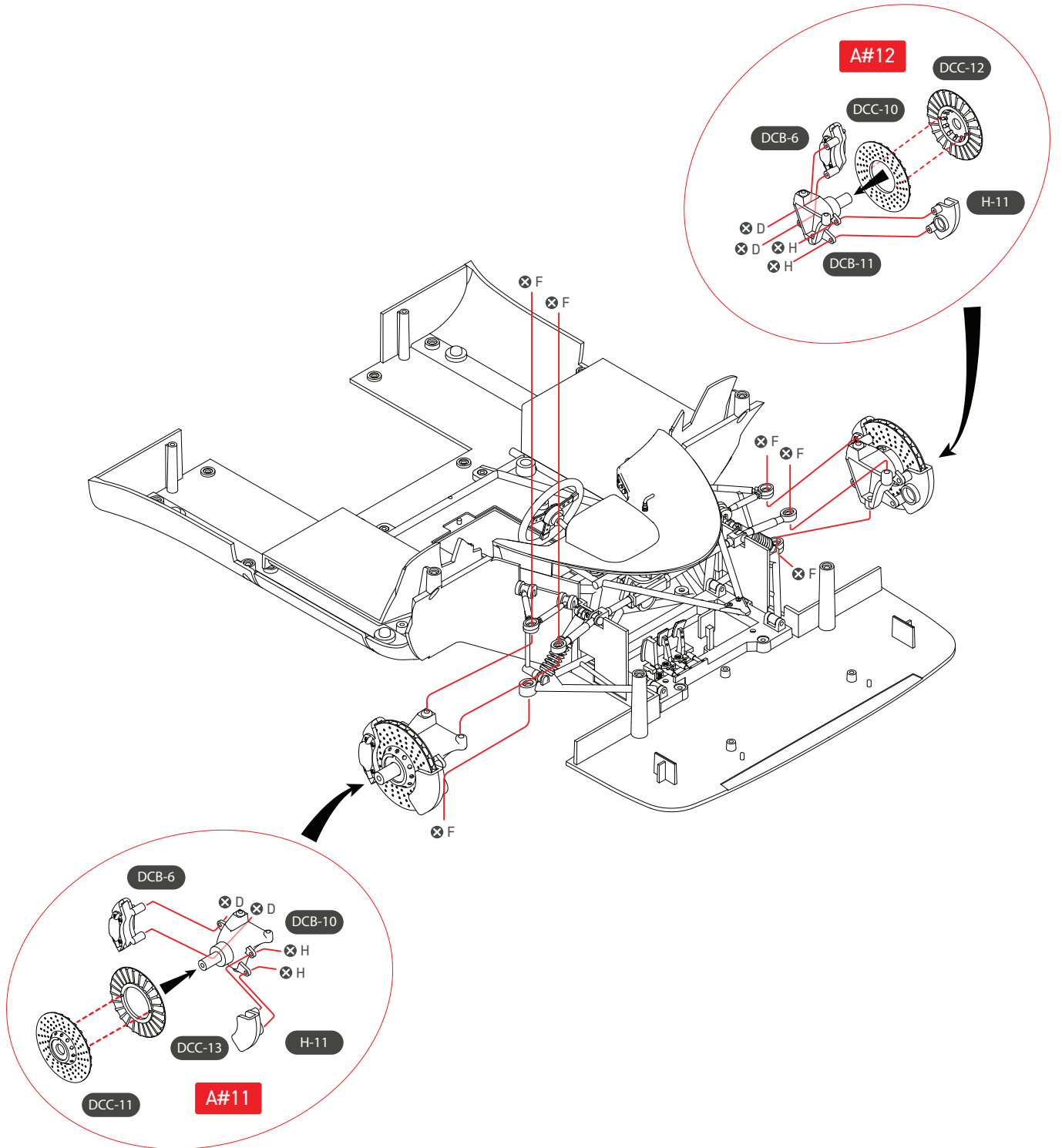

SCREW D = 4  
SCREW F = 6  
SCREW H = 4

11

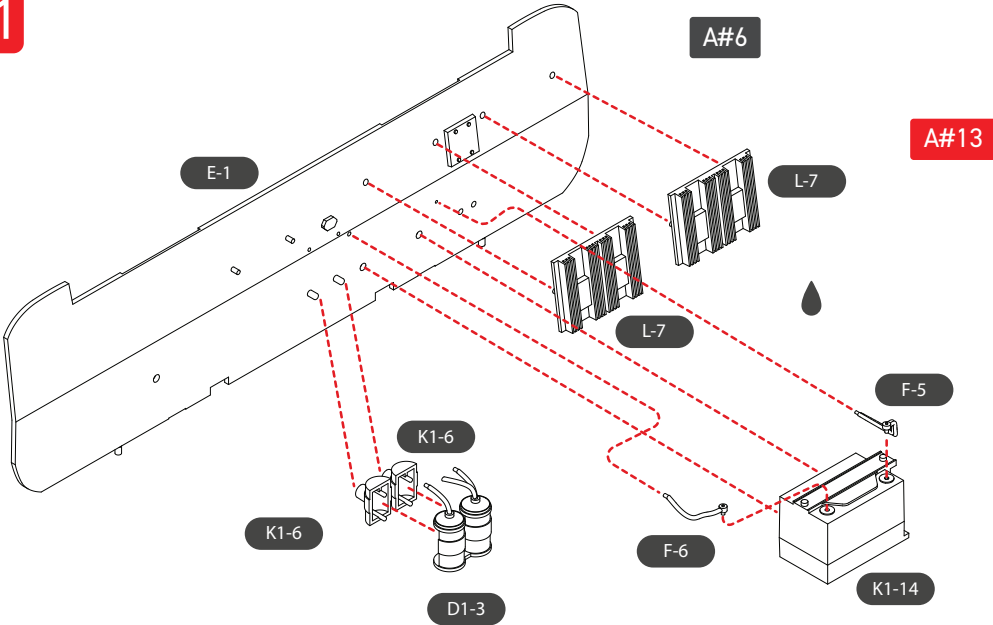

12

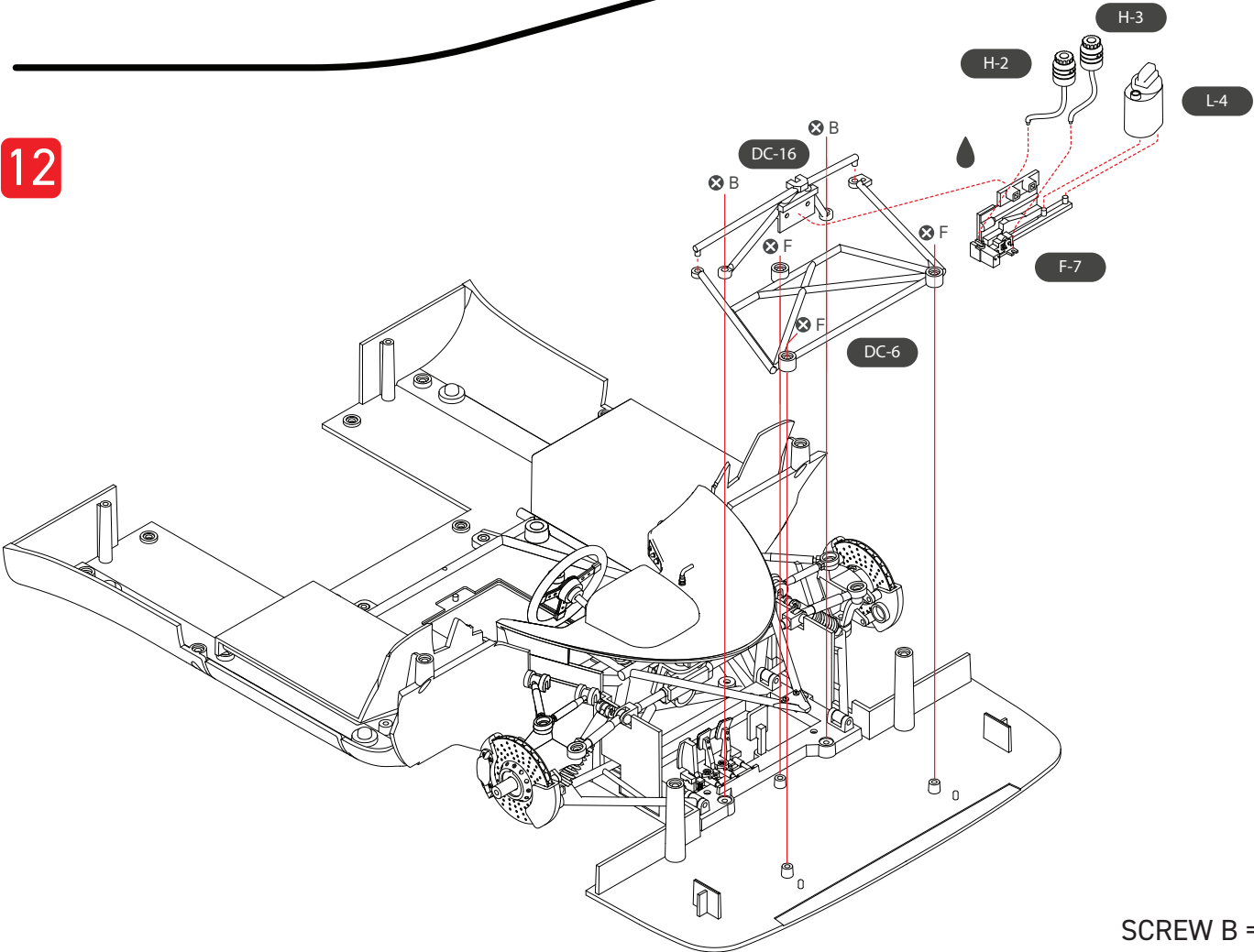

SCREW B = 2  
SCREW F = 3

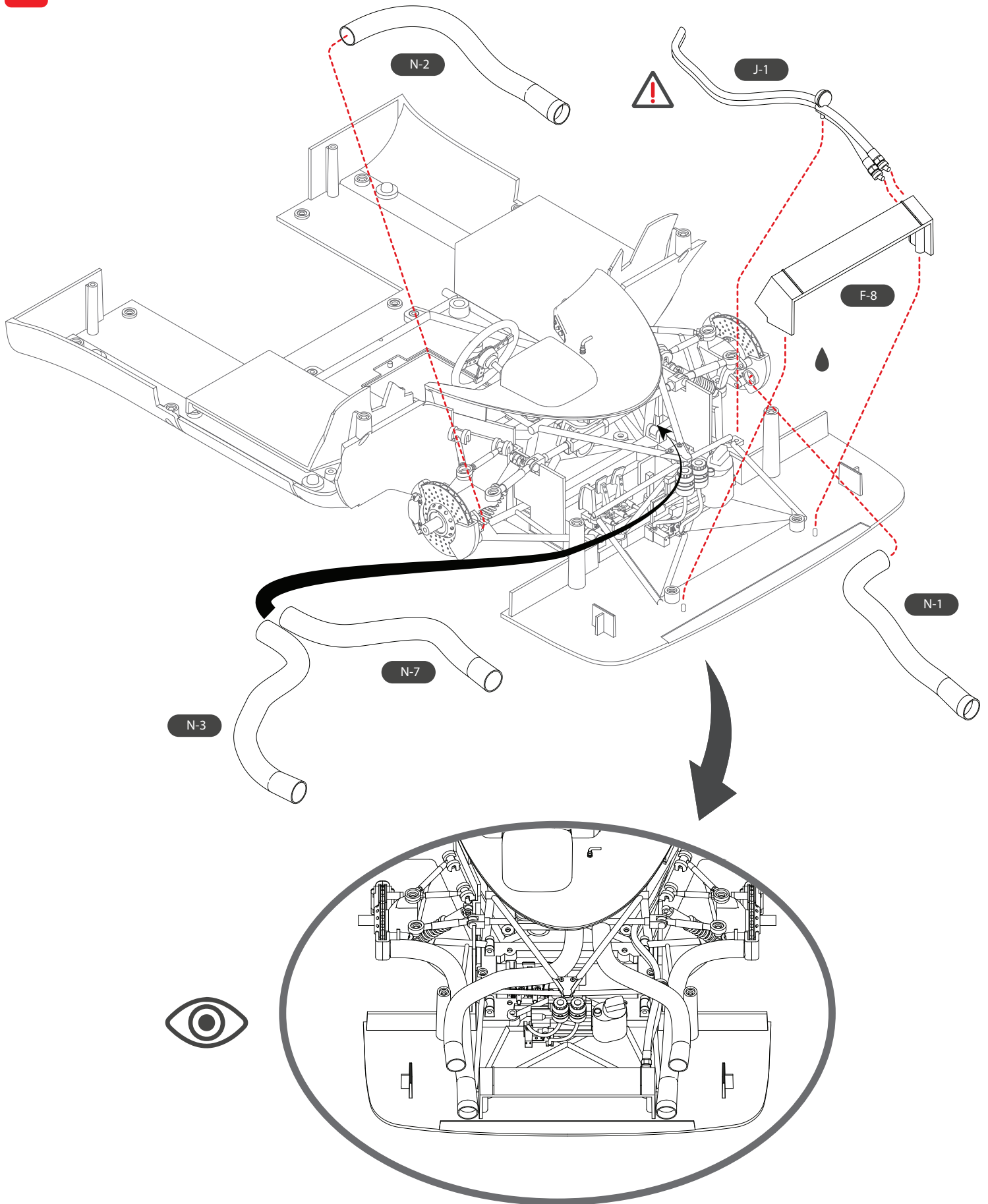

14



The Porsche 917 has two seats due to FIA regulations, which required sports cars to accommodate a passenger, emphasising their connection to road cars. The second seat was minimal to prioritise performance.

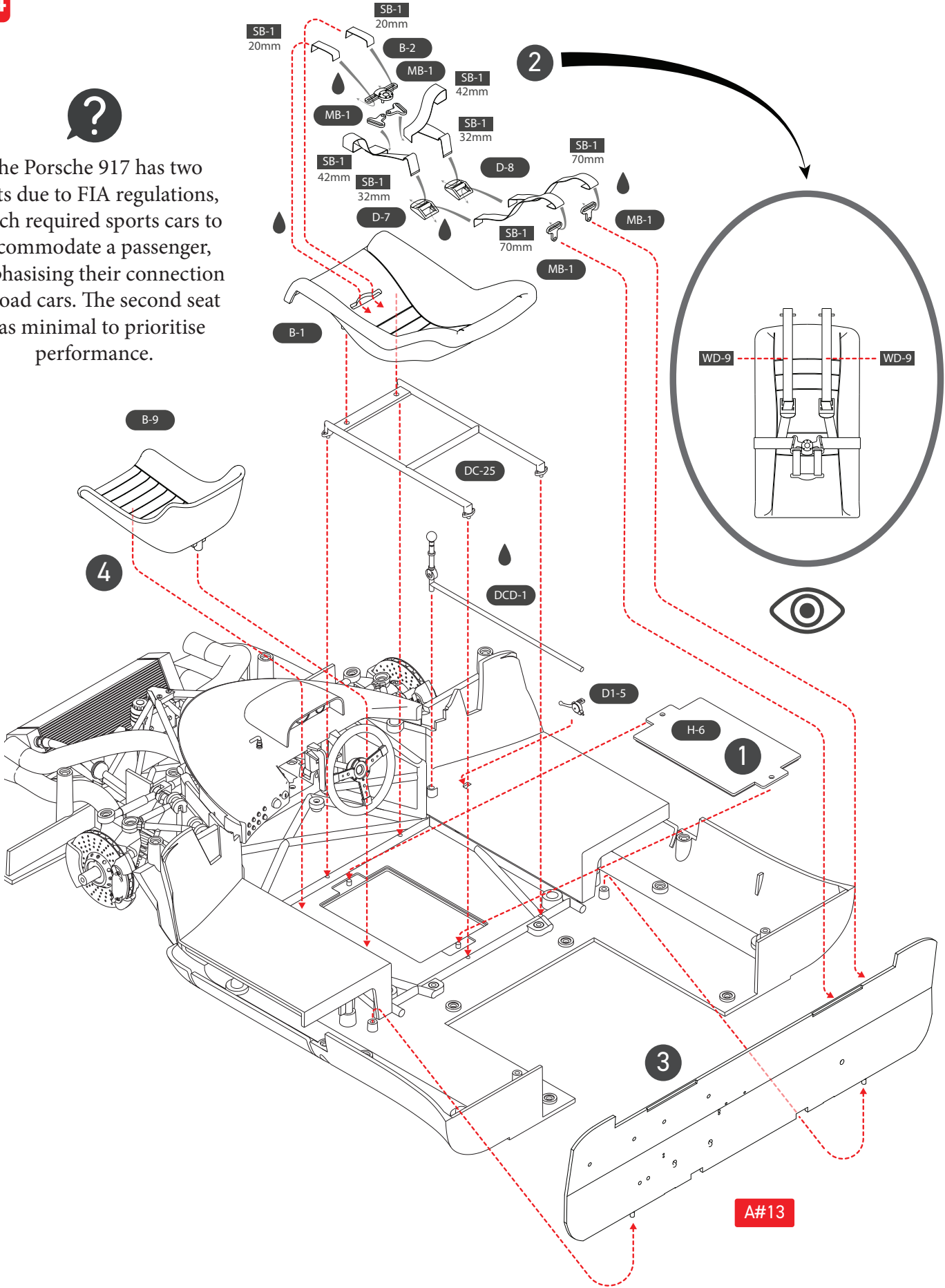



TU-1 100mm TU-1 100mm TU-1 110mm TU-1 138mm TU-1 139mm TU-1 145mm

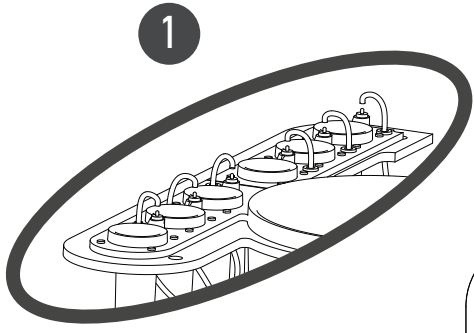

1

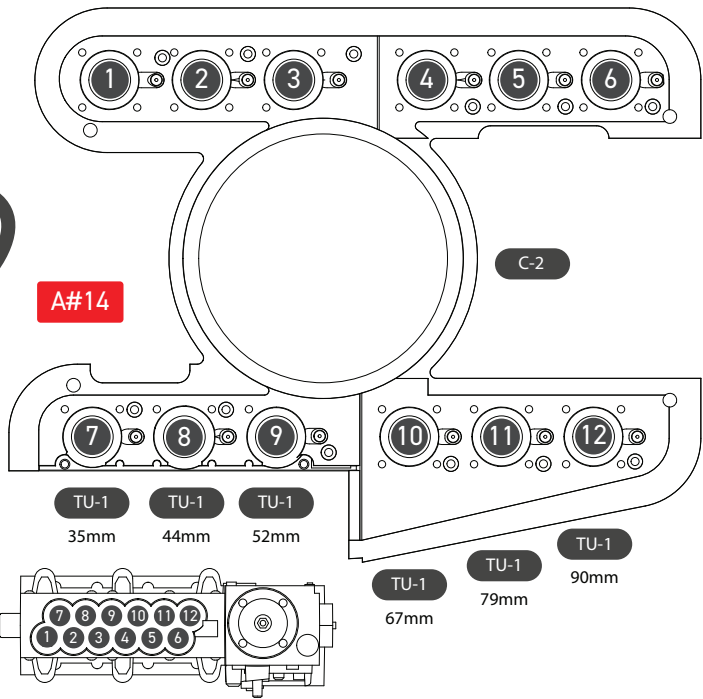

A#14

C-2



TU-1 35mm TU-1 44mm TU-1 52mm

TU-1 67mm TU-1 79mm TU-1 90mm

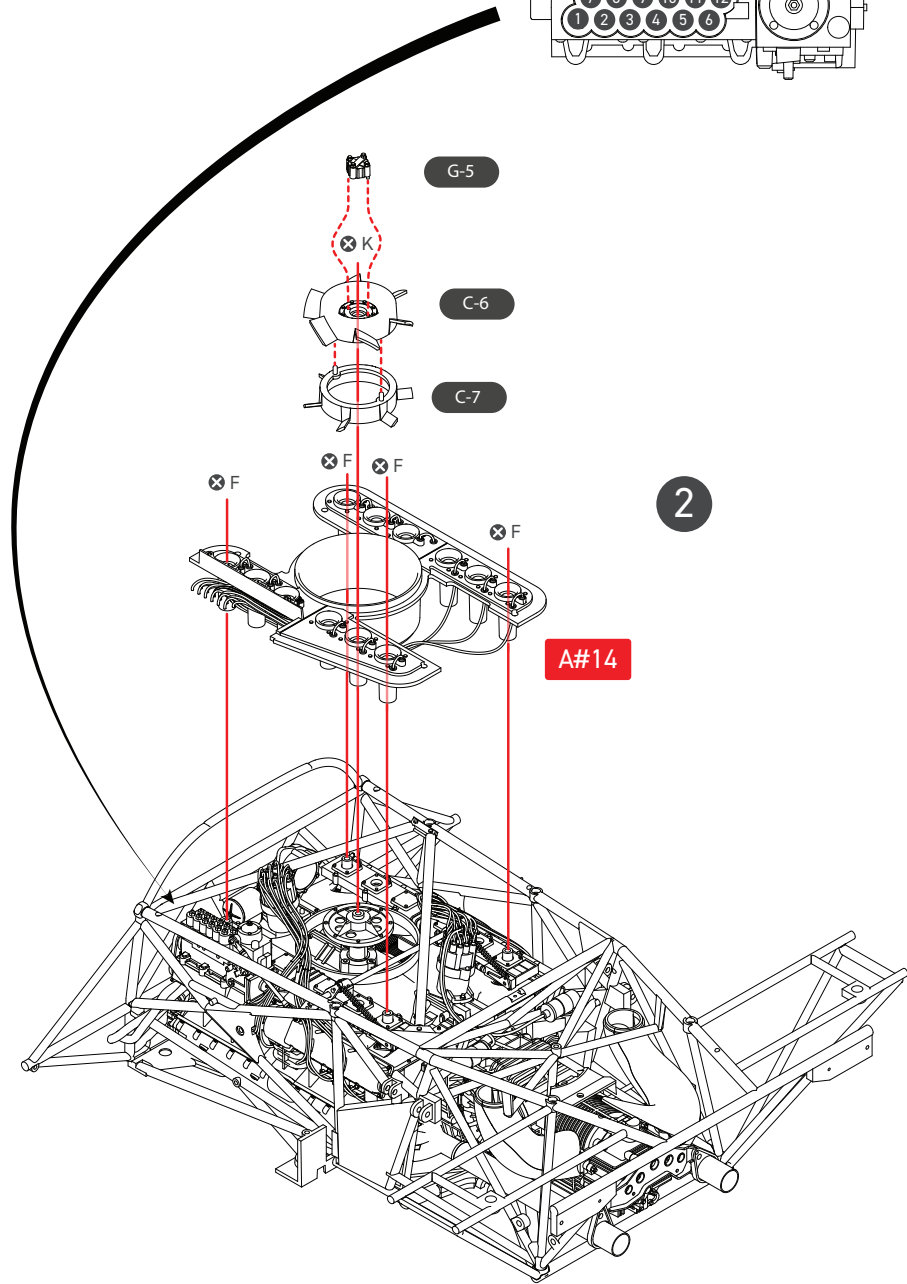

2

A#14

G-5

C-6

C-7

⊗ F ⊗ F ⊗ F ⊗ F

SCREW F = 4  
SCREW K = 1

16

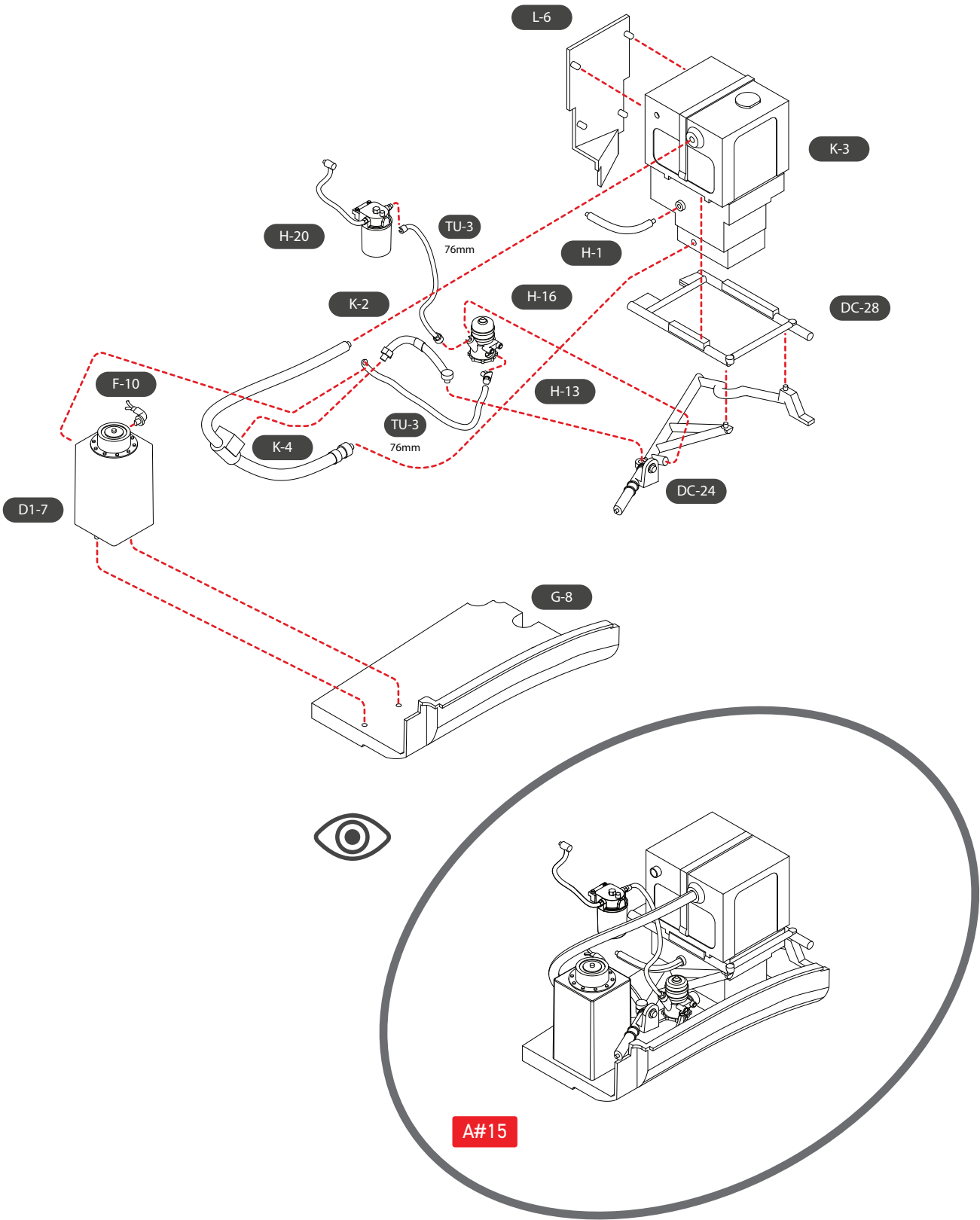



17

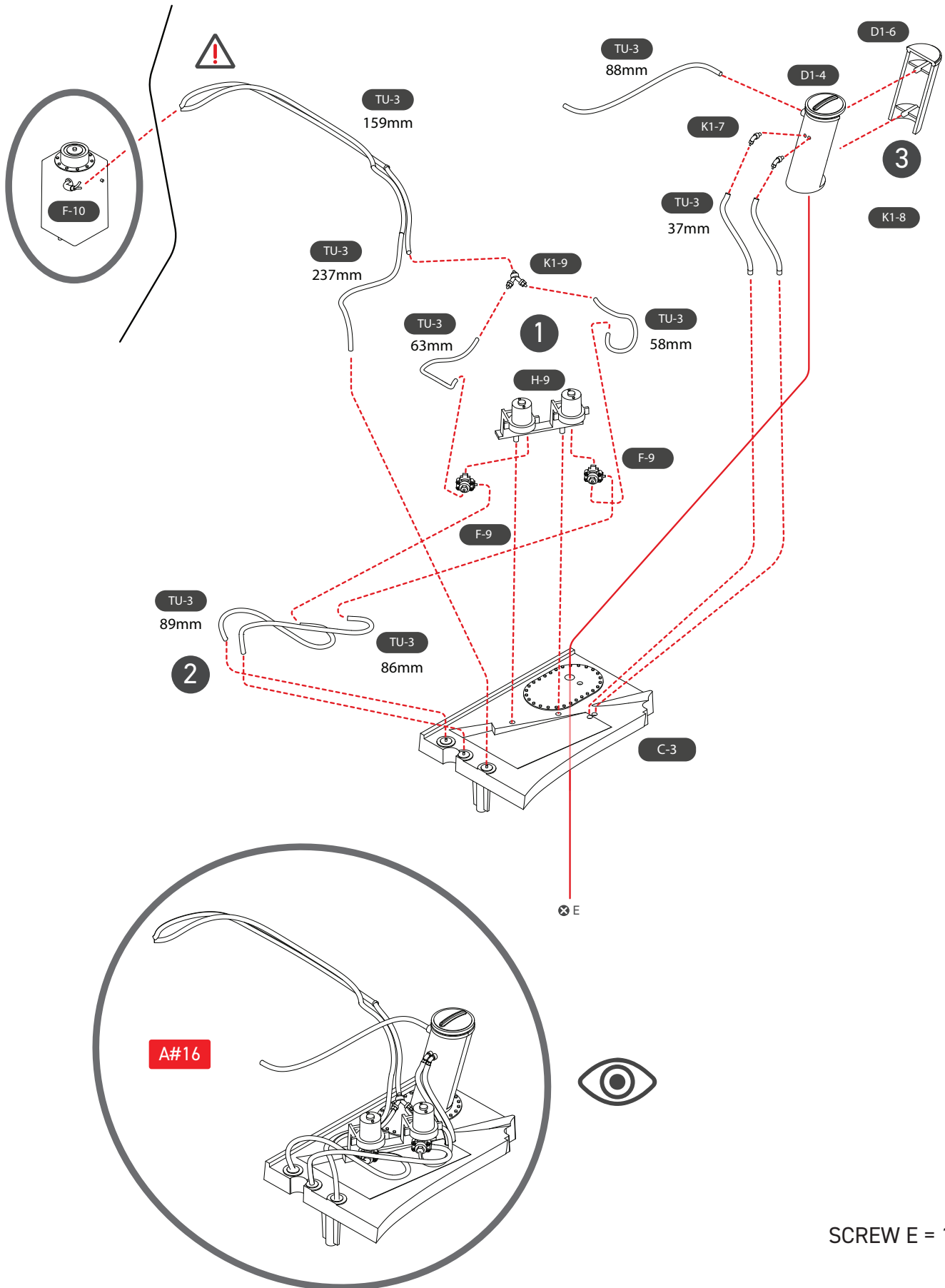

SCREW E = 1

18

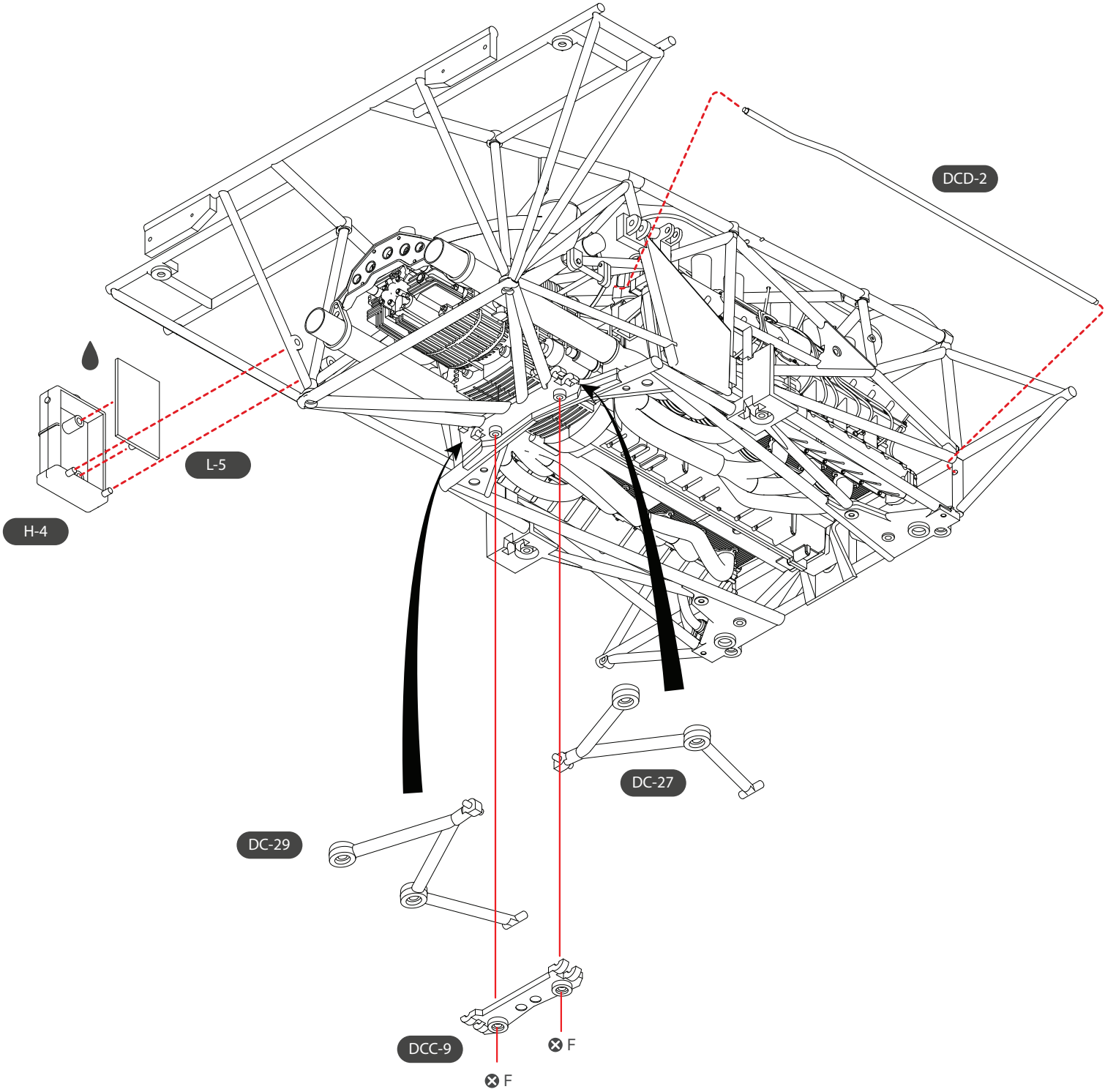

SCREW F = 2

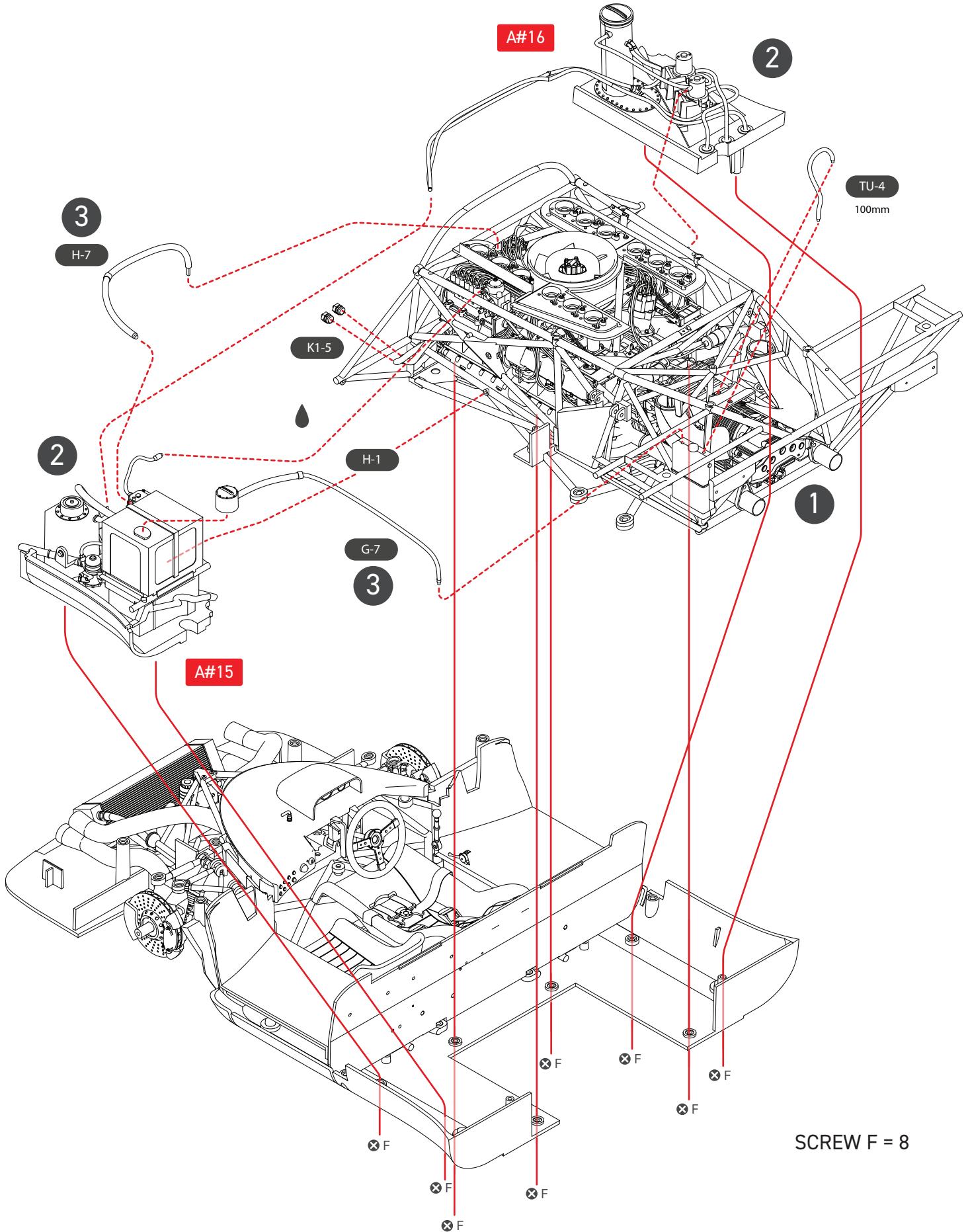

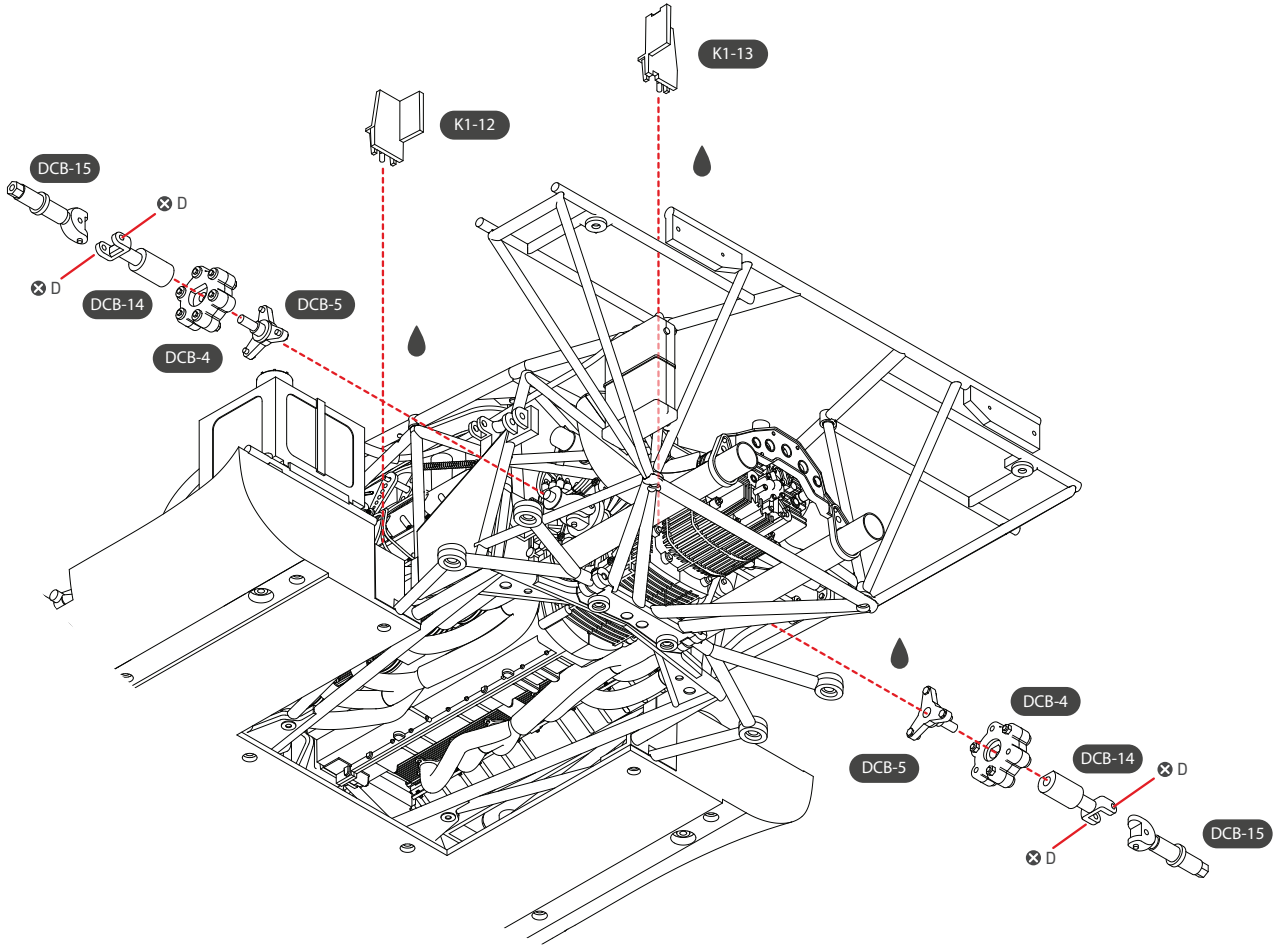

The use of a magnesium frame came with considerable drawbacks, including its delicate nature and susceptibility to combustion. To ensure reliability, the frame was gas-pressurised, with a pressure gauge enabling real-time monitoring by drivers and engineers during races.

SCREW D = 4

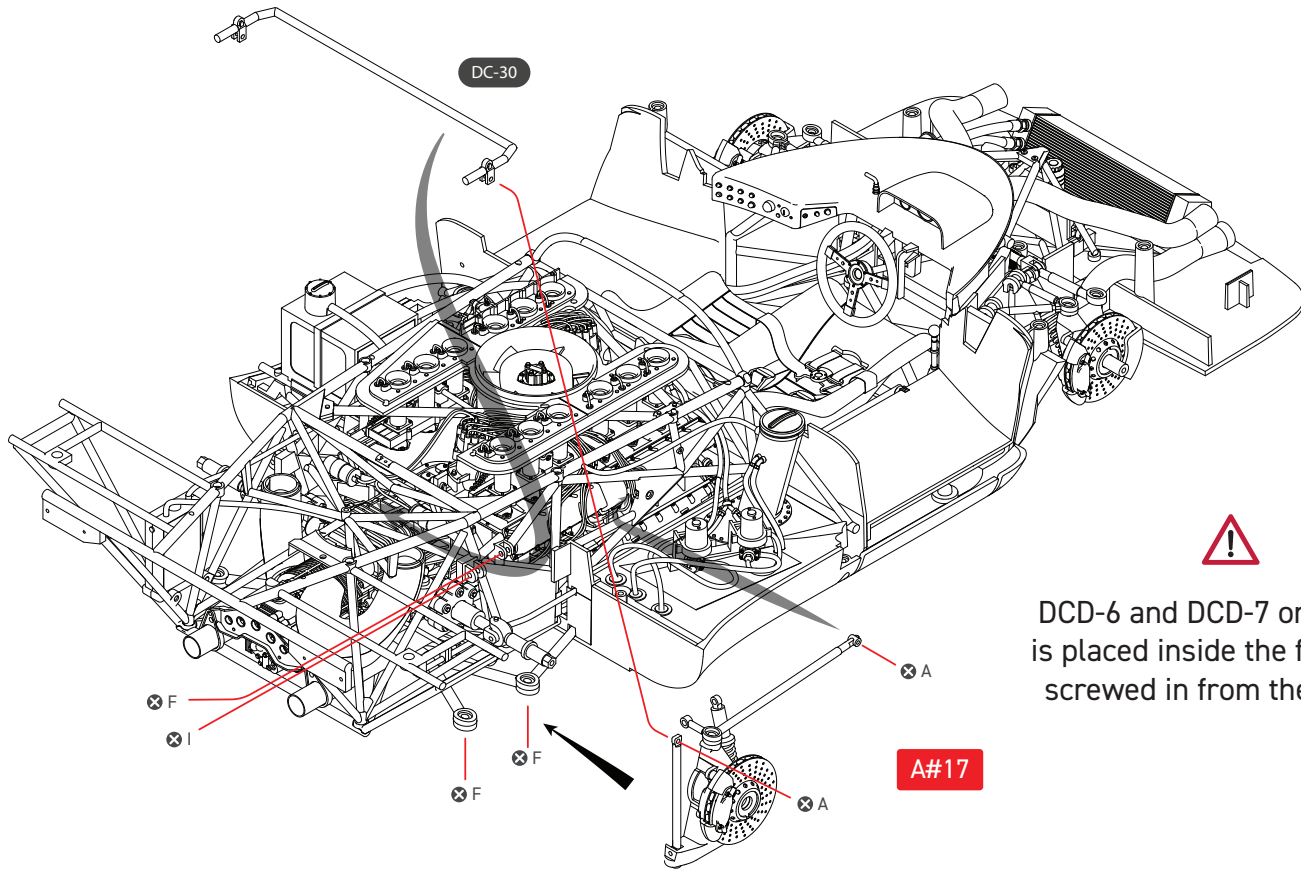

DCD-6 and DCD-7 on page 29 is placed inside the frame and screwed in from the outside

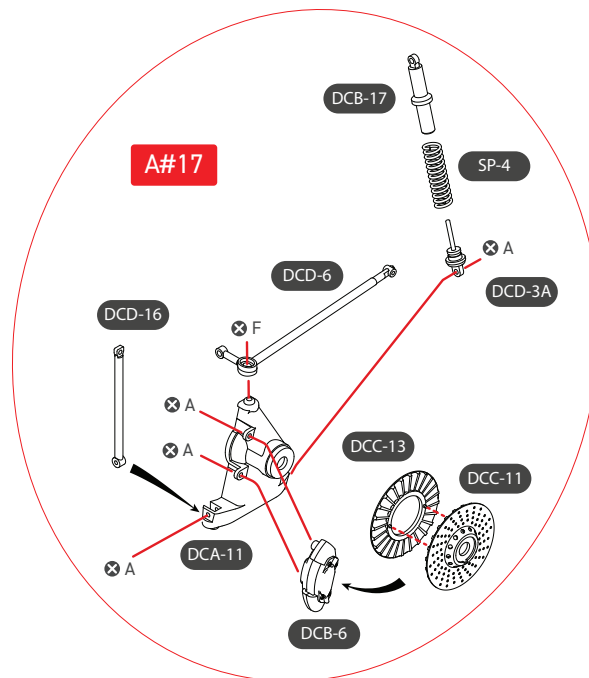

SCREW A = 6  
SCREW F = 4  
SCREW I = 1

22

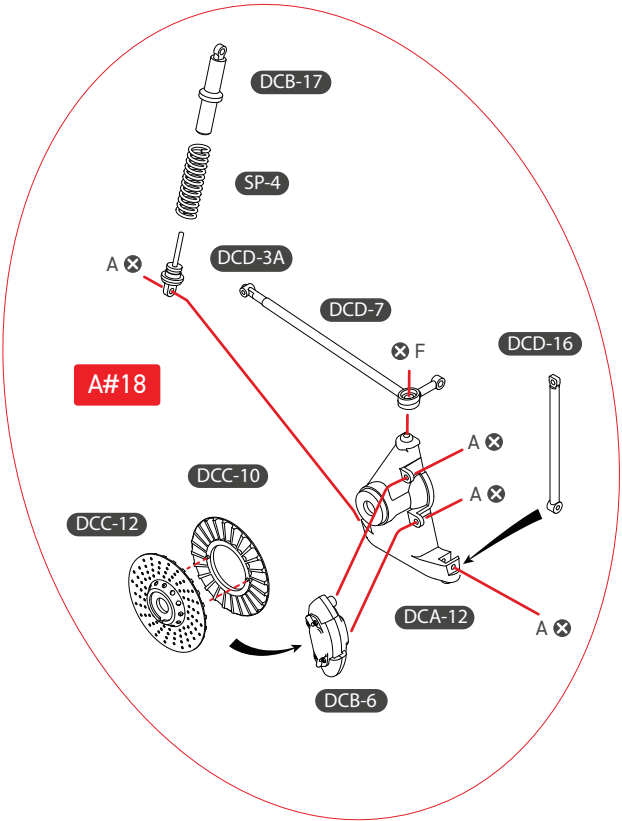
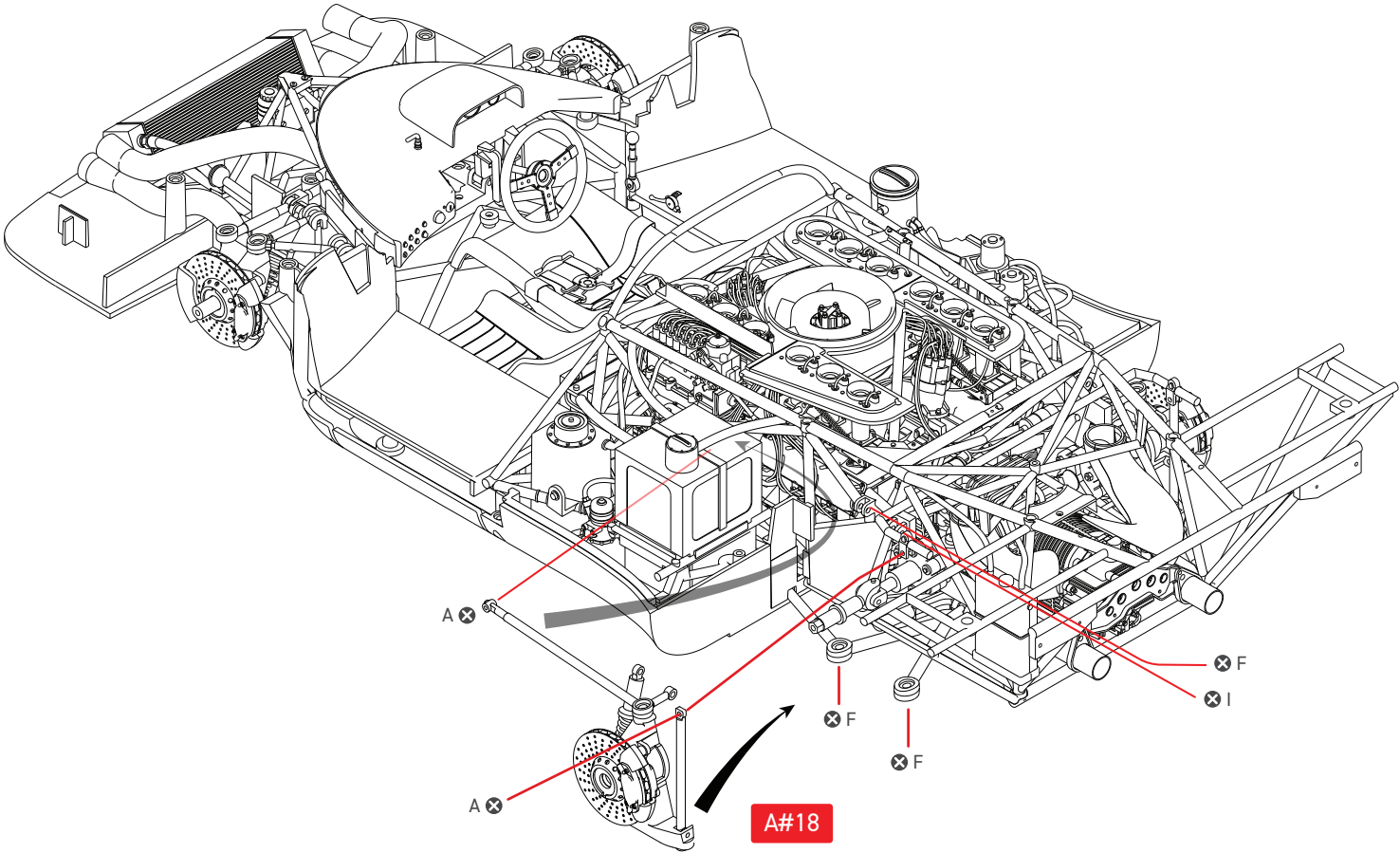

For difficult to reach fixing locations  
consider pre-threading them with  
screws and test fitting

SCREW A = 6  
SCREW F = 4  
SCREW I = 1



23

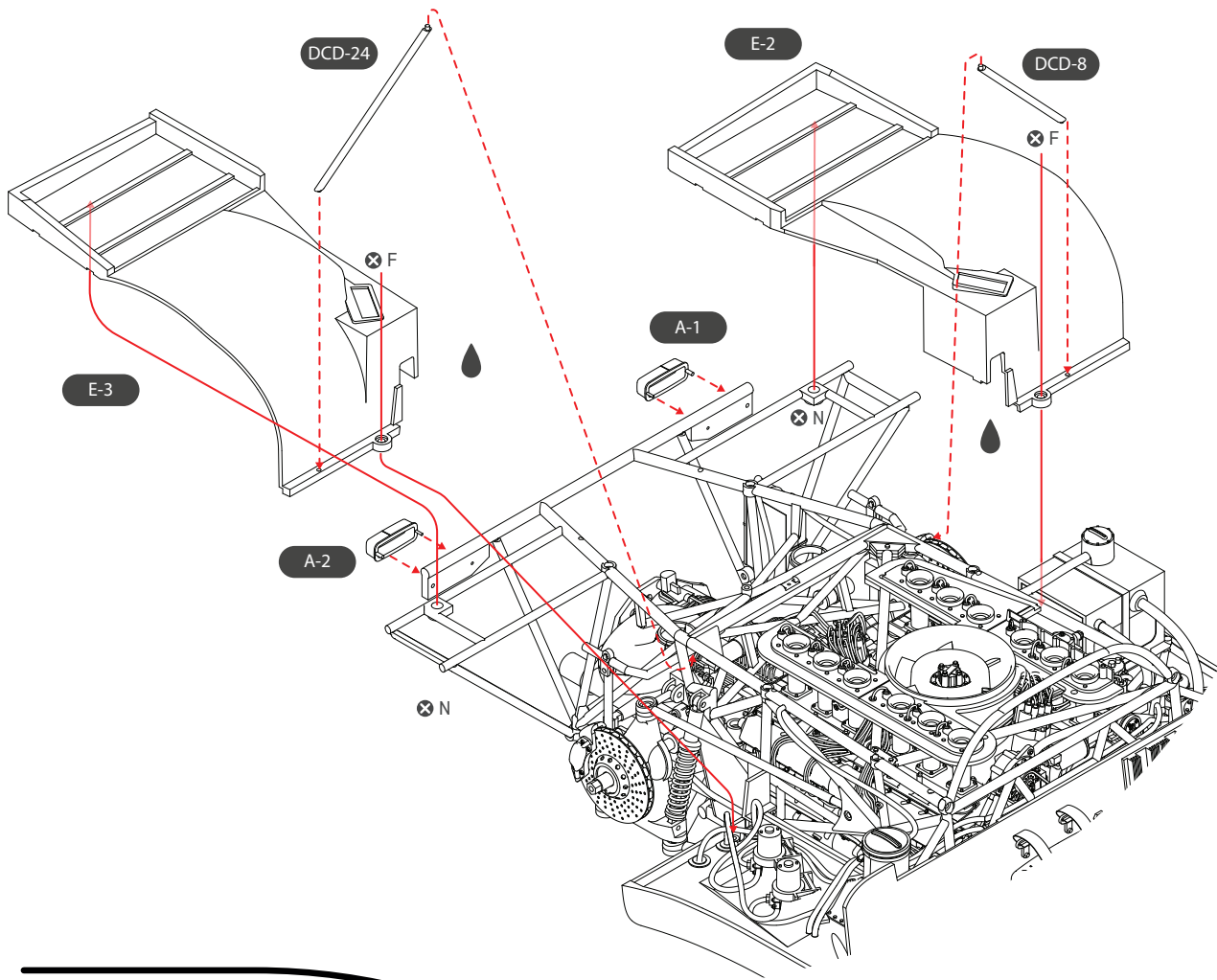

24

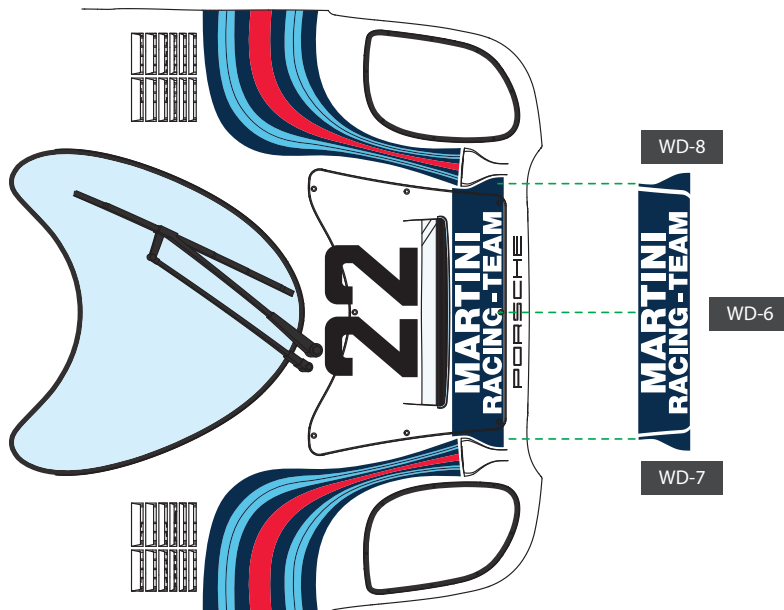

SCREW F = 2  
SCREW N = 2

25

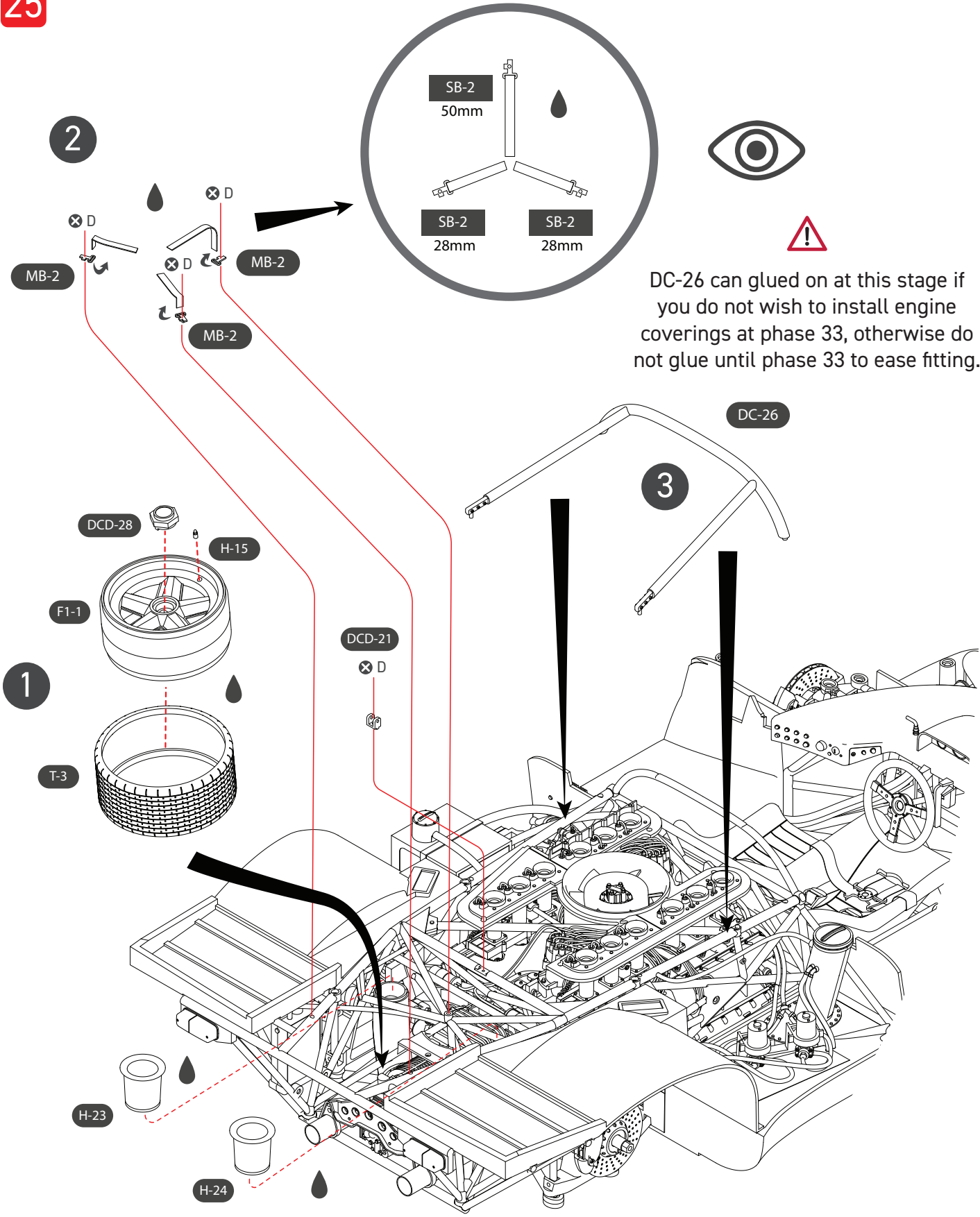

DC-26 can be glued on at this stage if you do not wish to install engine coverings at phase 33, otherwise do not glue until phase 33 to ease fitting.

SCREW D = 4



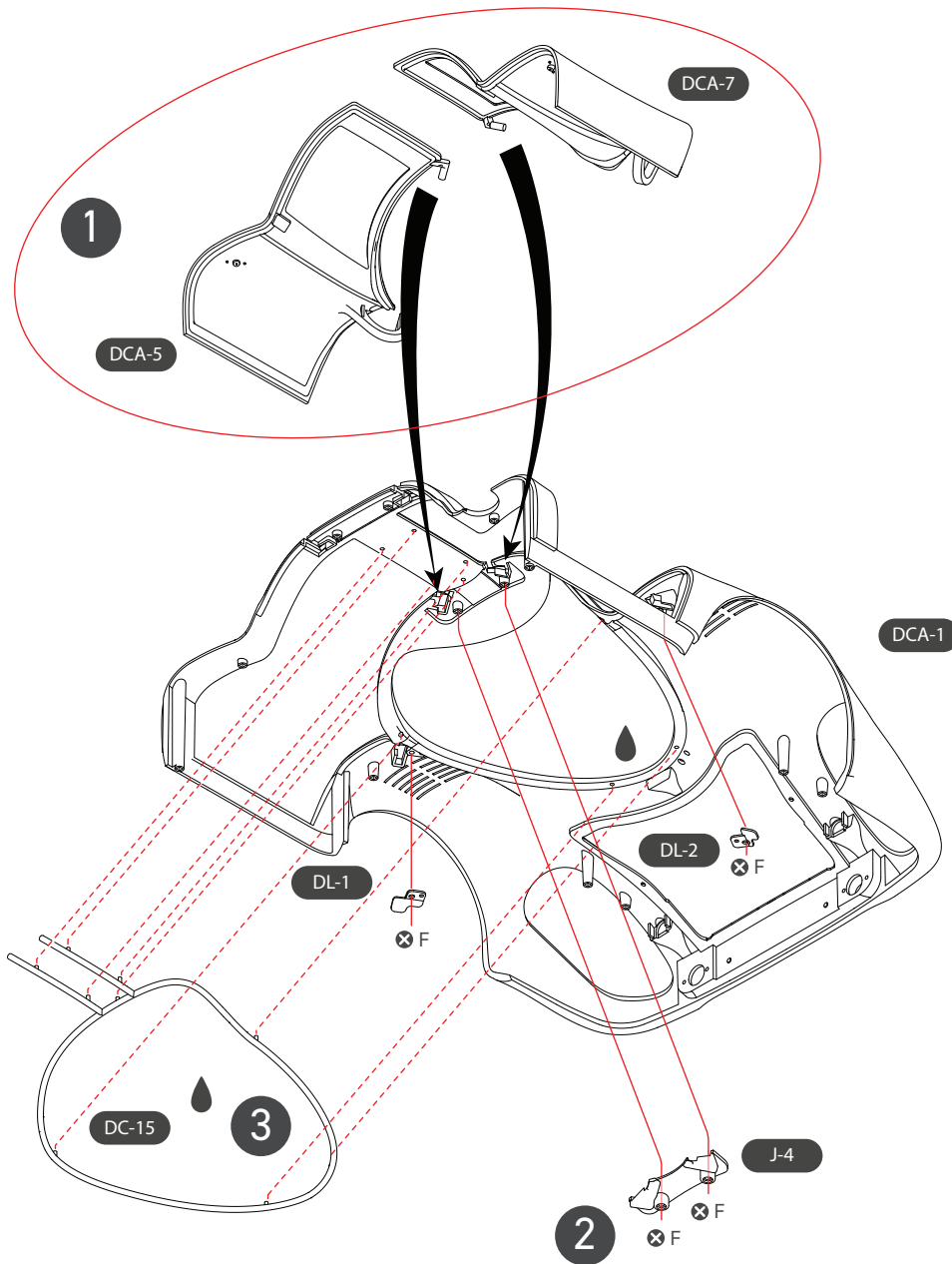

The Porsche 917 in an effort to save weight had no mechanism to keep the doors open, and were often held open by a rope tied to the air vent above the wheel arch or even propped up by something such as a simple piece of wood.

SCREW F = 4

27

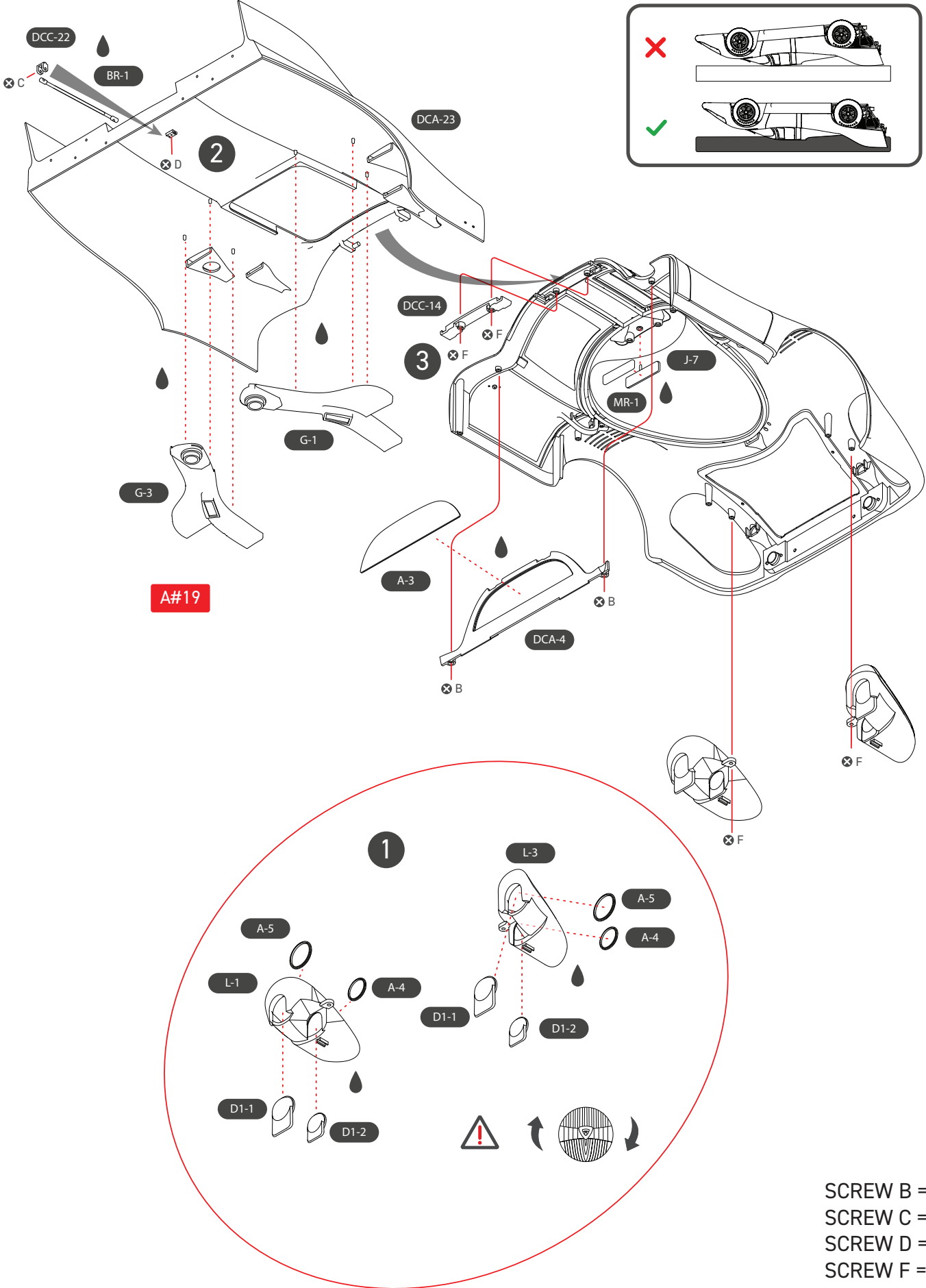



Use a clear drying glue on clear plastic parts to avoid fogging

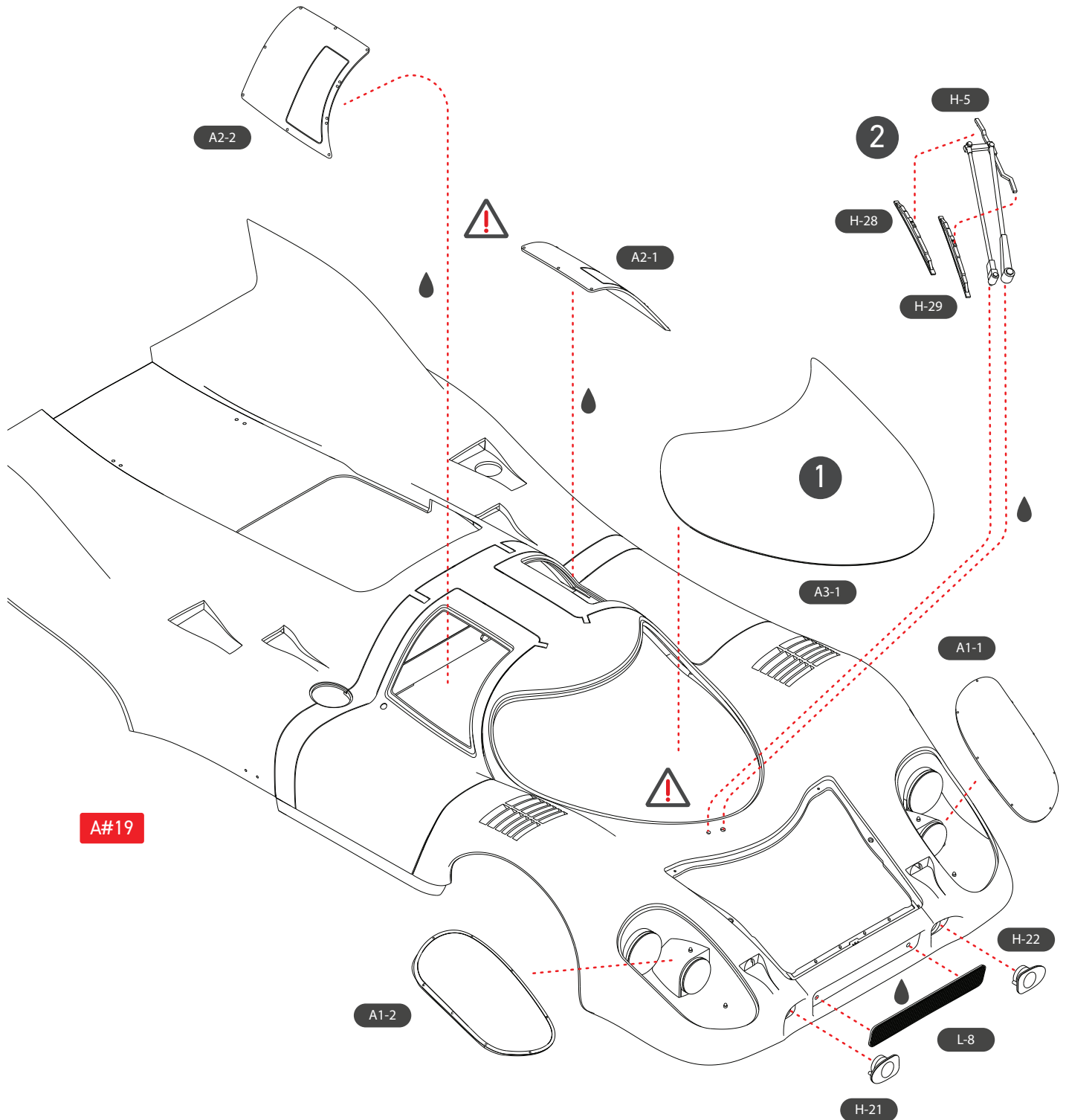

29

A#19

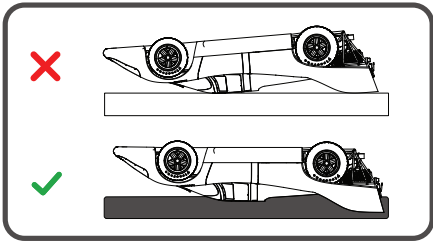
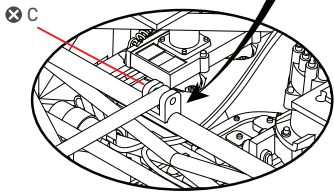
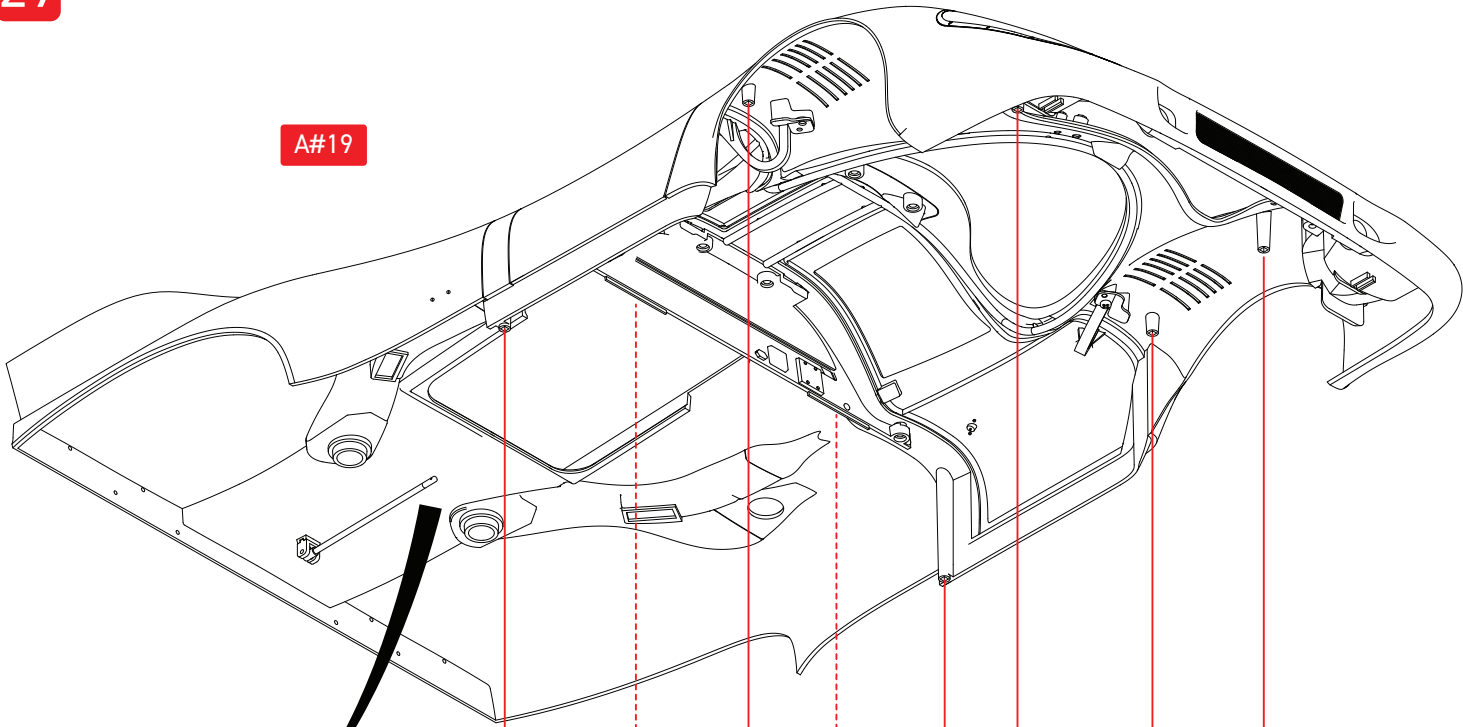

Consider using foam to cushion the vehicle when working on the underside

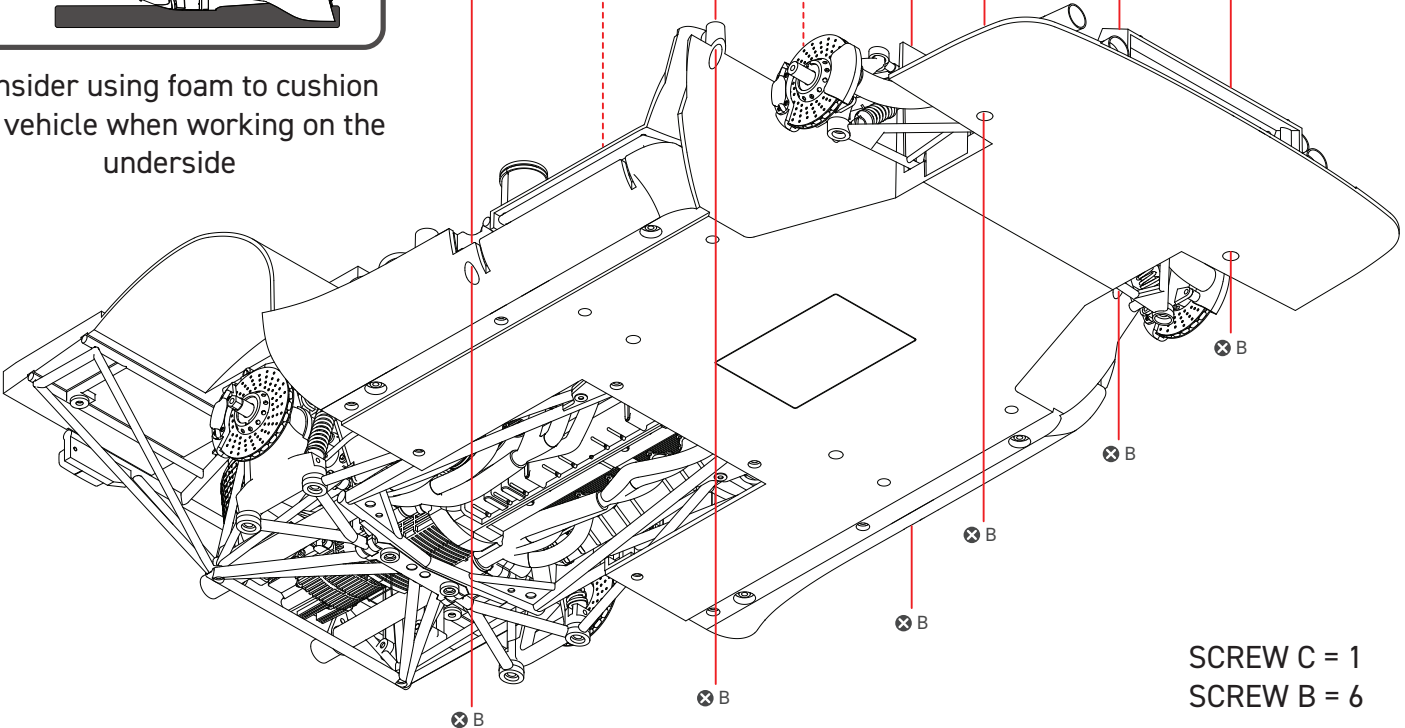

SCREW C = 1  
SCREW B = 6

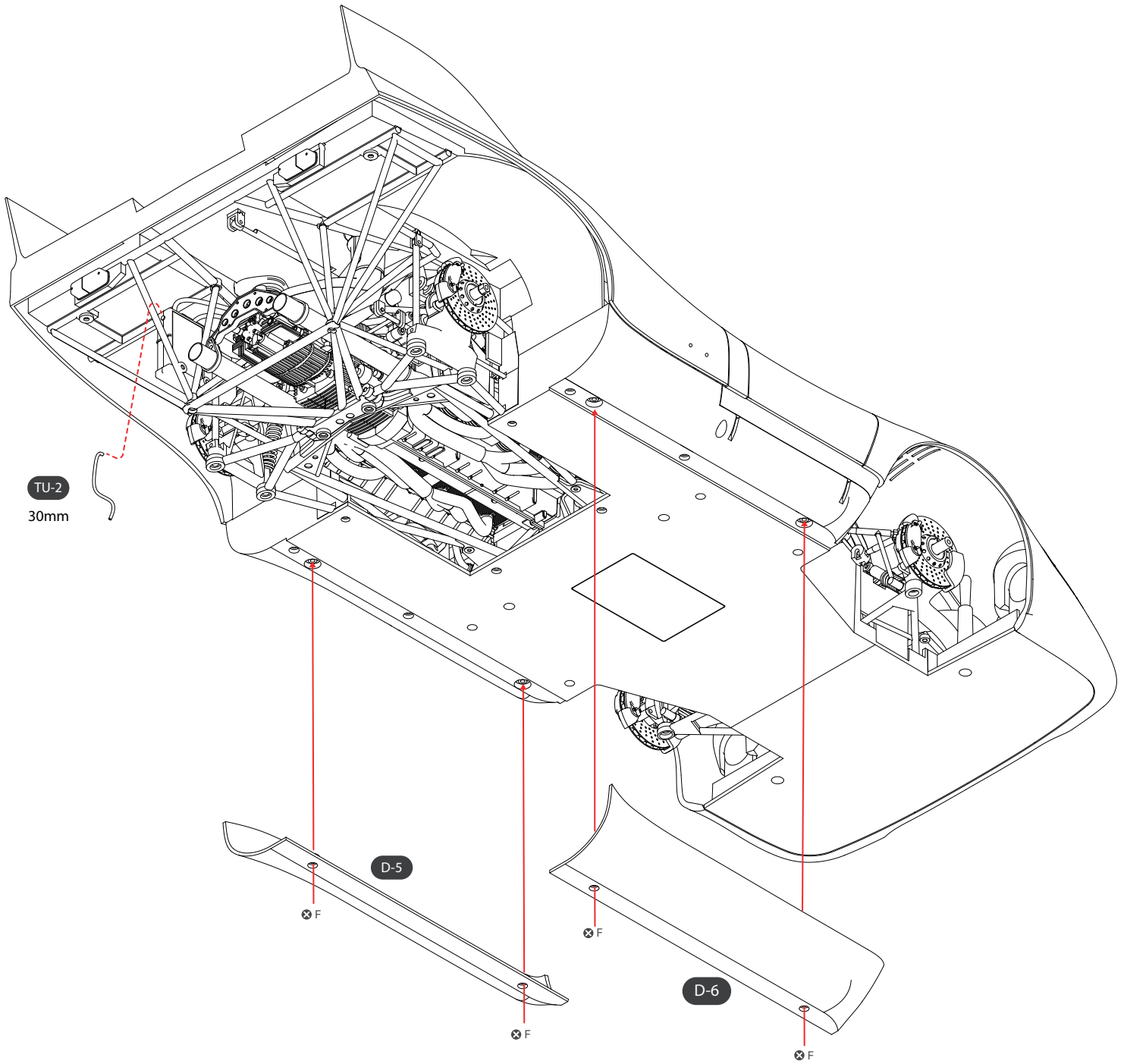

TU-2  
30mm

D-5

D-6

SCREW F = 4

30

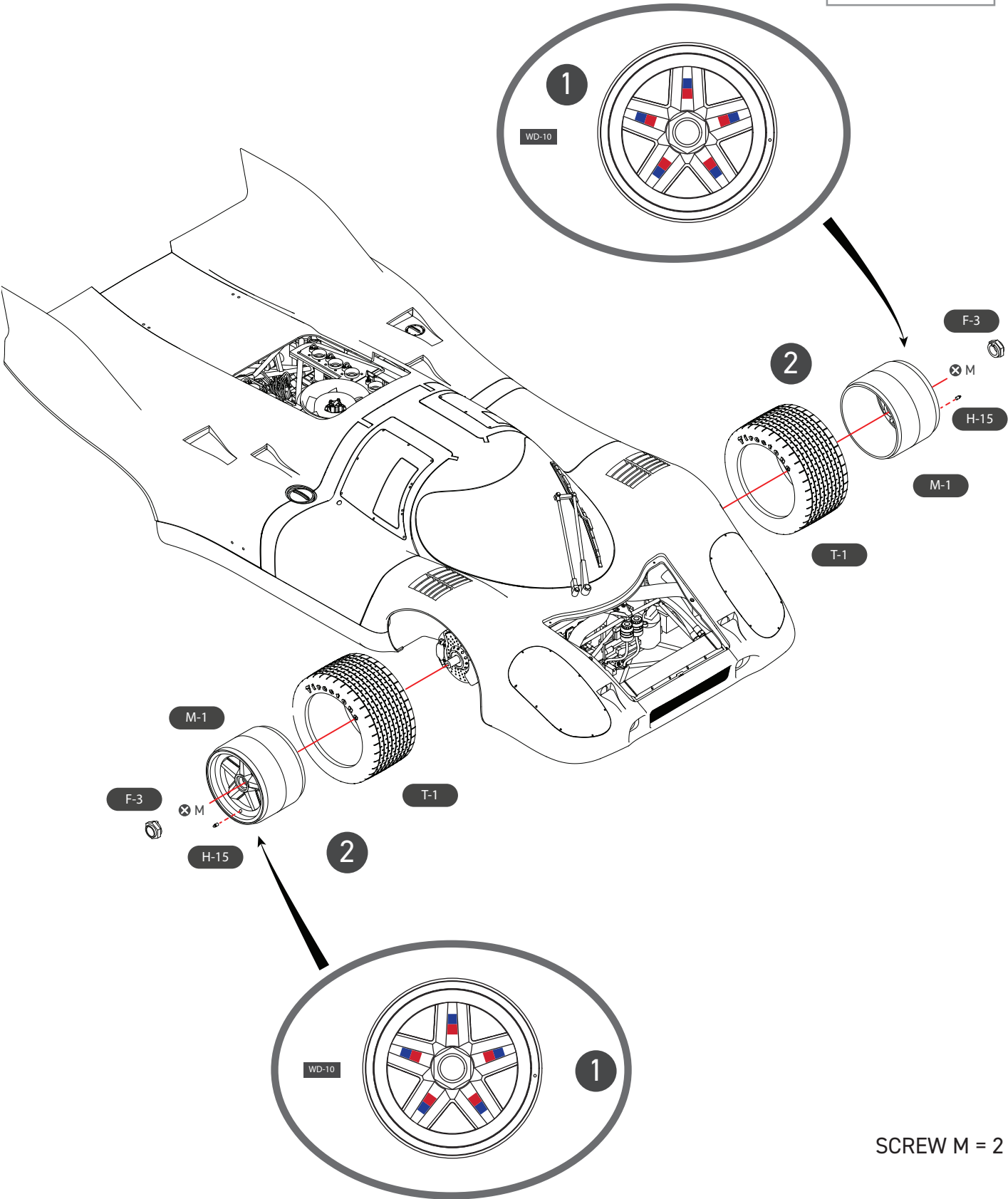
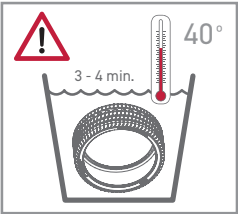

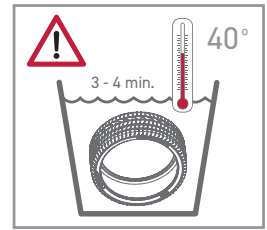

Soften the tyres with warm water to make fitting easier

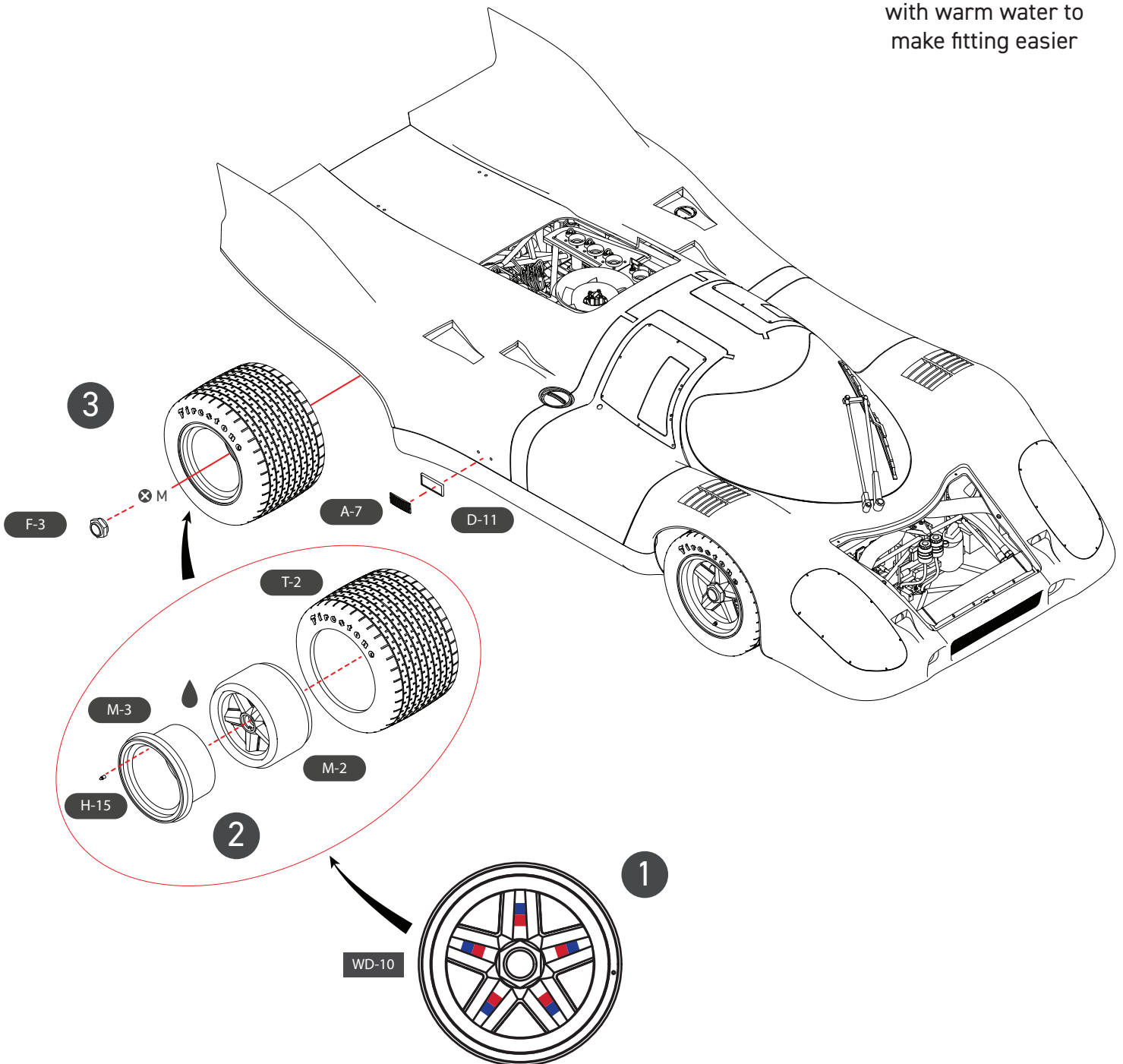

SCREW M = 1

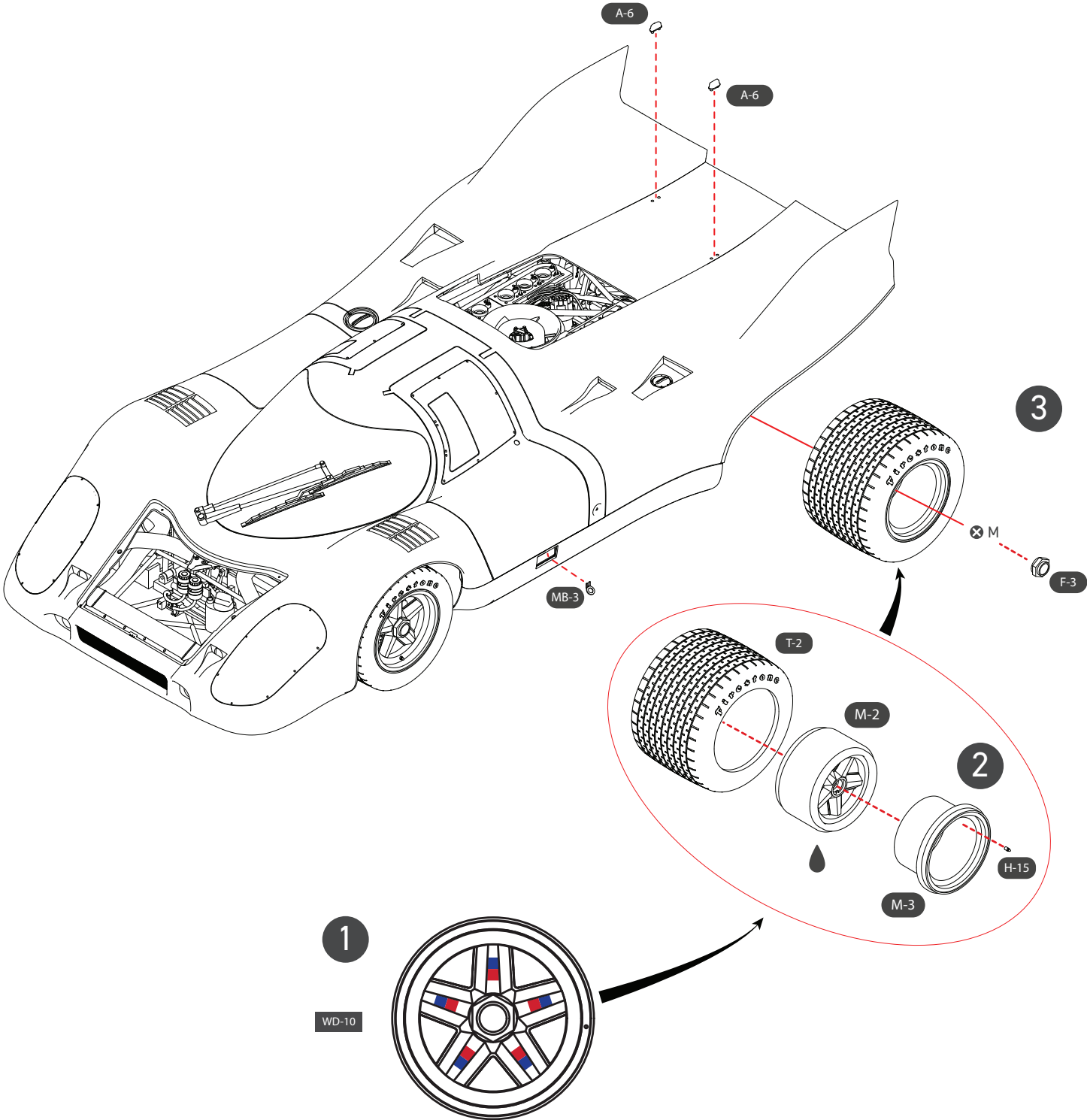

SCREW M = 1



The engine covers, intake covers and front hatch are designed to be removable, so you can either display showing the engine off, or glue them on.

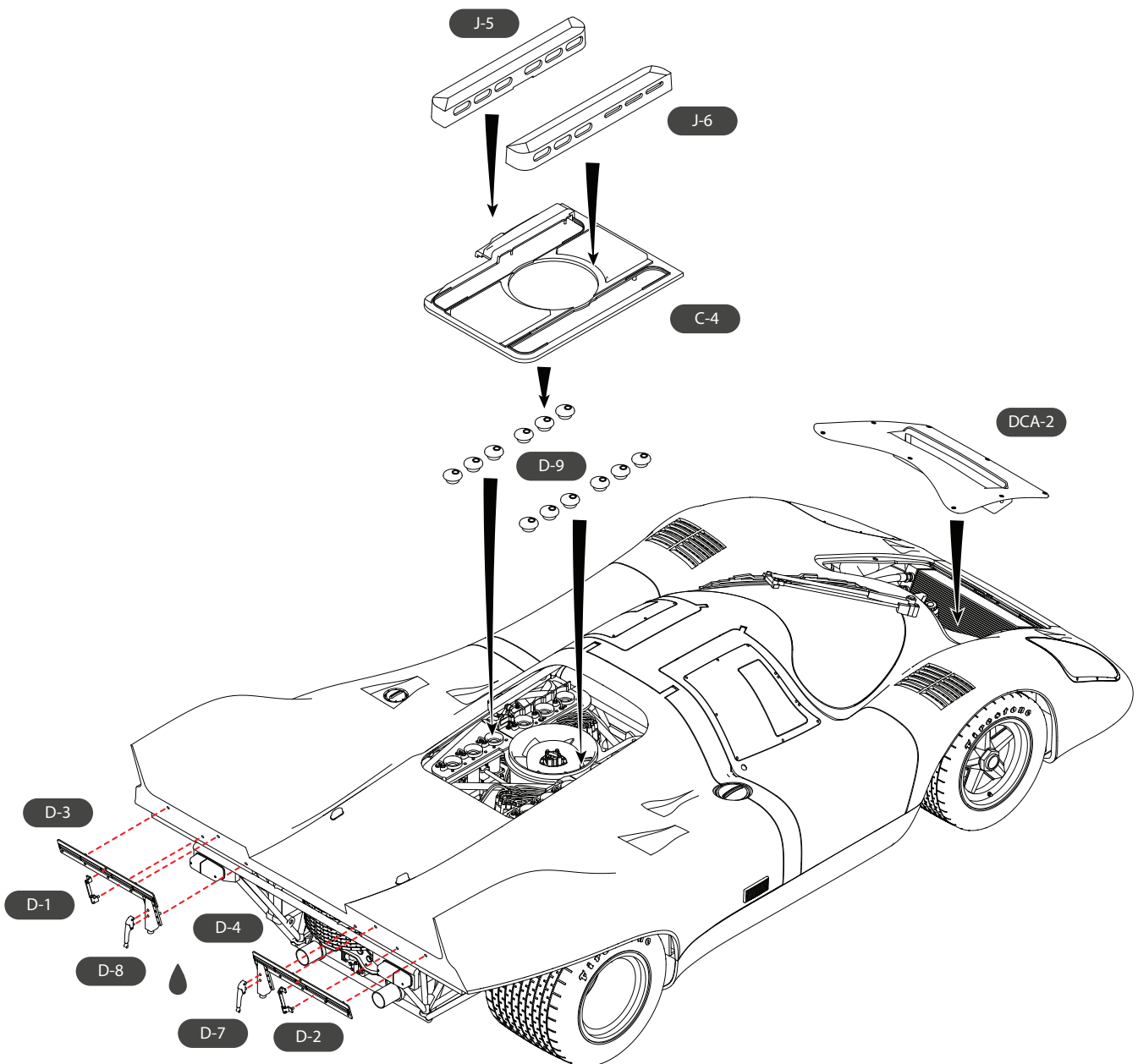

34

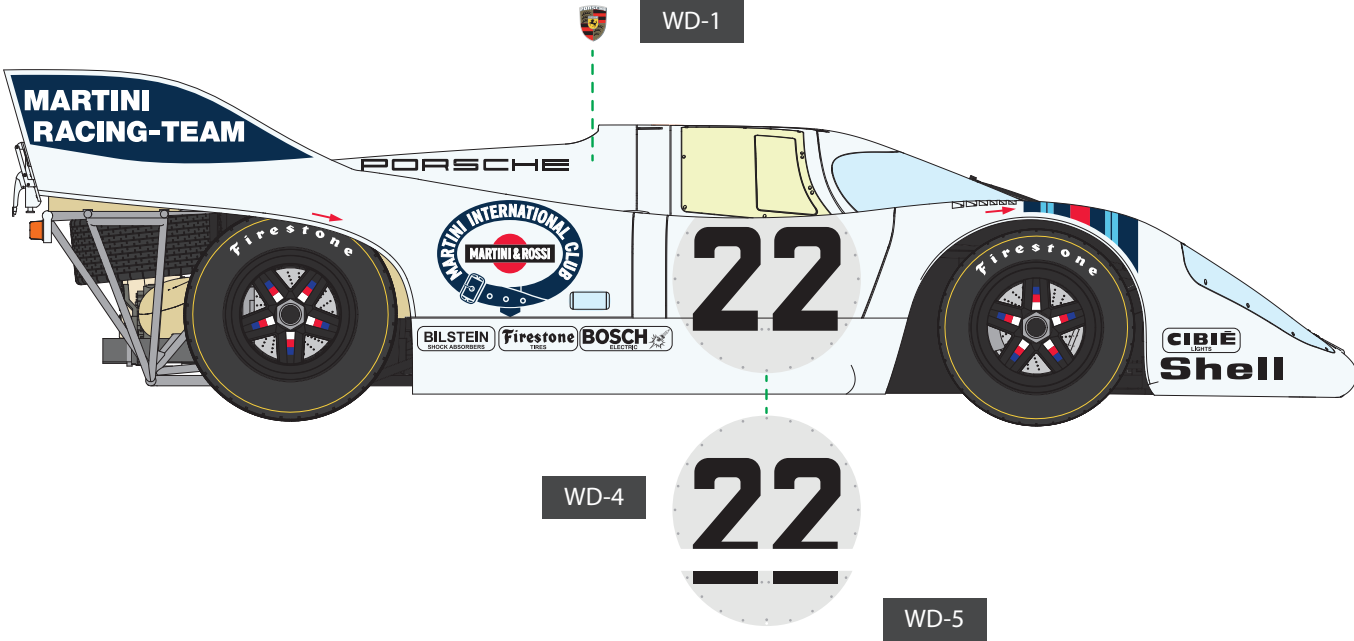
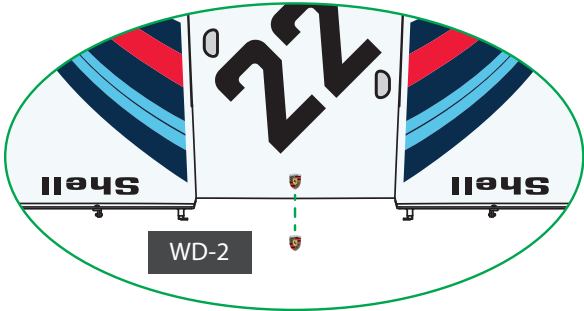
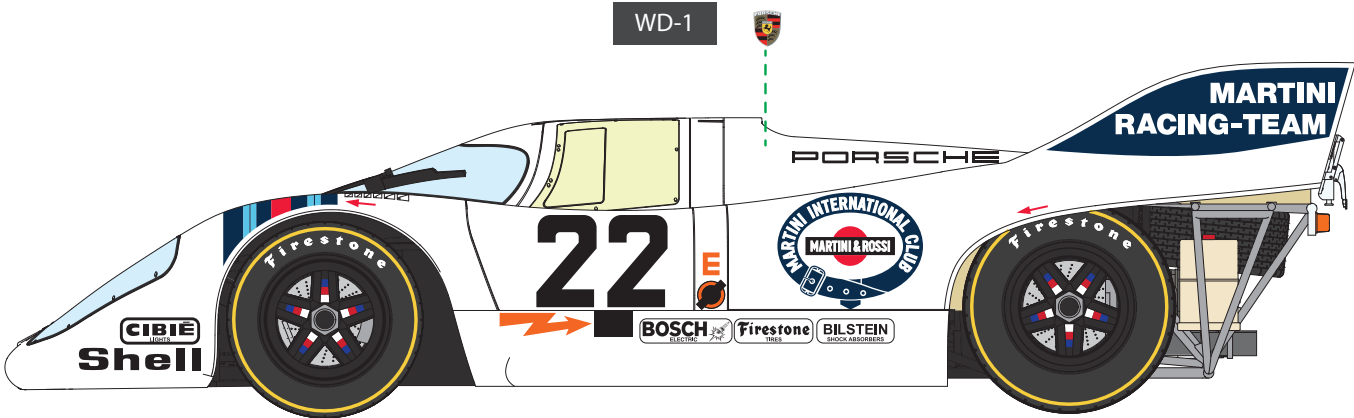

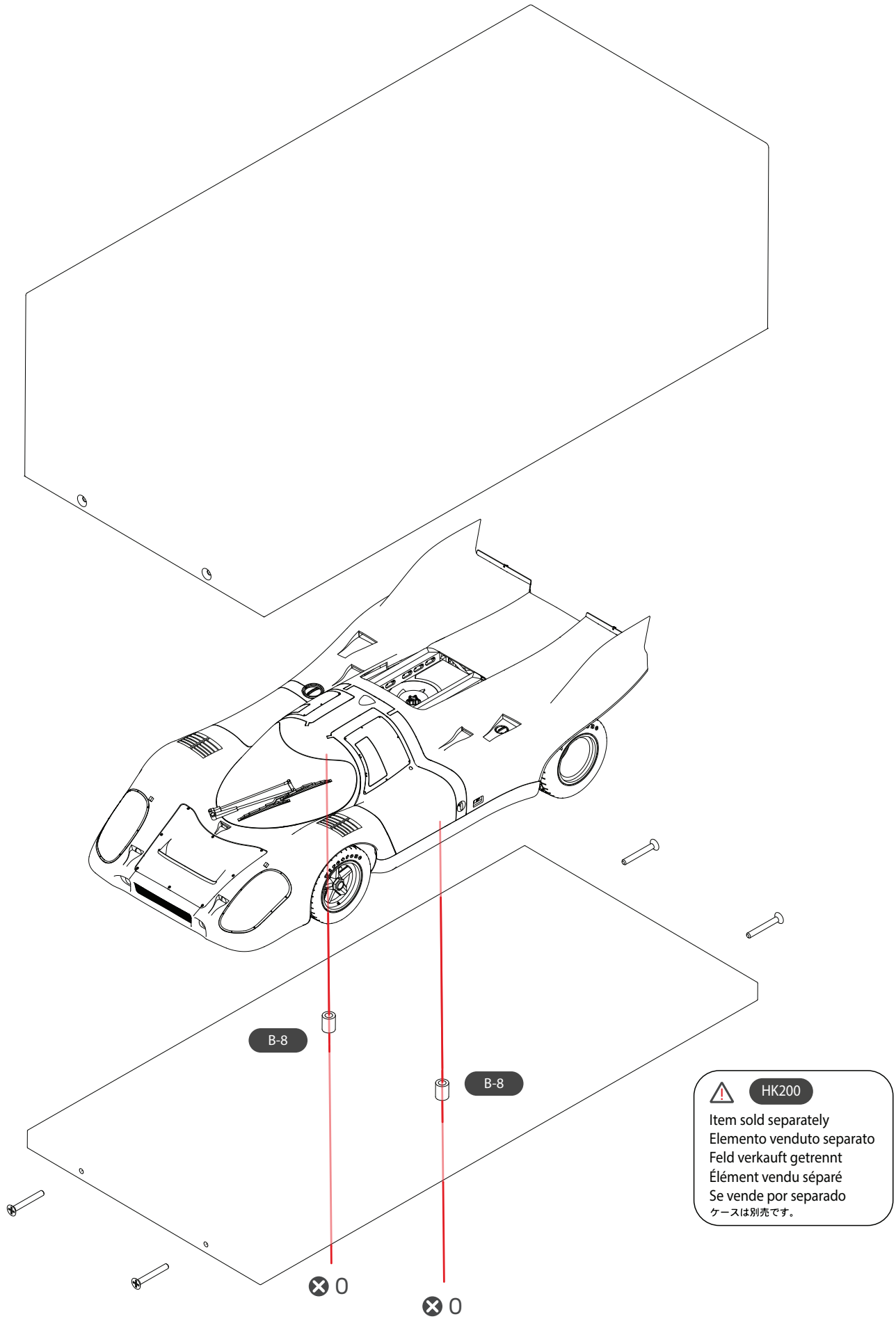



**Pocher**  
Die-Cast Model Kits

## Pagani Utopia Coupé - Rinascimento Lucido

CODE: HK120

AGE 14+

556+ PARTS



## Porsche 917K - Gulf Edition

CODE: HK118

AGE 14+

312+ PARTS



## Lotus 72D - 1972 British GP Emerson Fittipaldi

CODE: HK114

AGE 14+

477+ PARTS



Display your model in  
style with the Pocher  
Car Display Case\*

CODE: HK200



\*model not included

Discover more and elevate your collection - visit [pocher.com](http://pocher.com)



# Pochoer<sup>®</sup>

Die-Cast Model Kits



Porsche, the Porsche shield and the distinctive design of Porsche cars are trademarks and trade dress of Porsche AG. Permission granted.



MARTINI, THE BALL AND BAR LOGO AND THE MARTINI RACING STRIPES ARE TRADEMARKS.

Manufactured by: Hornby Hobbies Ltd.  
Westwood, Margate, Kent CT9 4JX, UK  
+44 (0) 1843 233525  
customerservices.uk@hornby.com

EU Authorised Representative: Hornby Italia SRL  
Viale dei Caduti, 52/A6, Castel Mella (BS), Italy, 25030  
+39 0687501292  
customerservices.it@hornby.com

USA Authorised Representative: Hornby America Inc.  
Lakewood Industrial Park, 4620 95th St SW, Bldg. 6, Suite A, Lakewood, WA, 98499  
+1 877 358 6405  
customersupport@hornby.us

