

Mercedes-Benz 500SEC

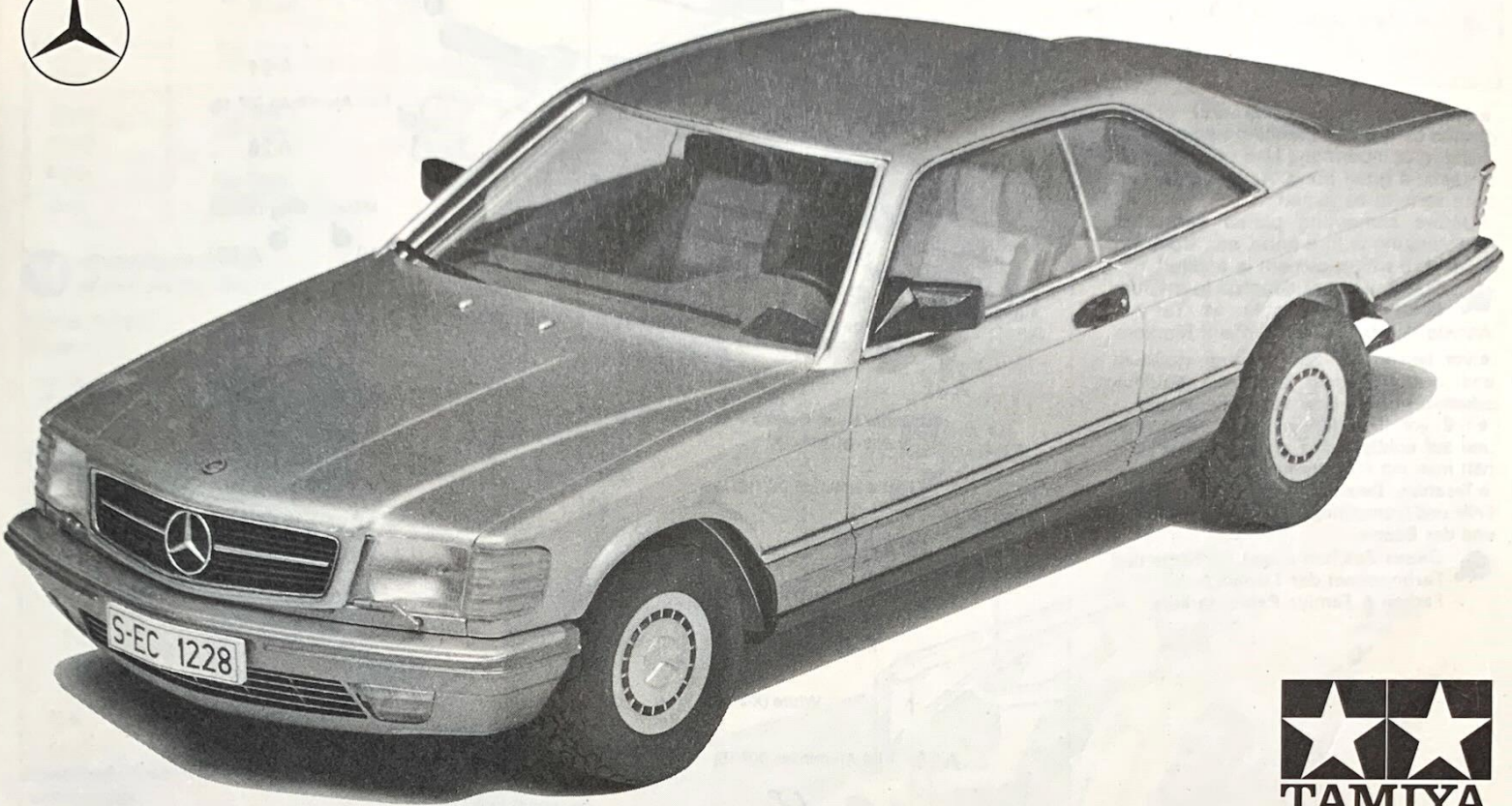

For more than 40 years, Mercedes-Benz has pioneered and developed safety into their great cars, and have made them sought after all over the world. The release of the new 500SEC Coupe has again proven that they are leaders in the field of first class luxury vehicles. In recent years the Mercedes-Benz Company has done away with the familiar boxy shape and sharp edges of the classic Benz, and have produced another classic style in the wind tunnel tested coupe body. This hard-top styled 2 door coupe has reduced the lift forces at the front axle for improved road handling, and the driver has a much better view of all four corners of the car. The front, spoiler shaped bumper also help to reduce the lift forces, and the side shields, along with the bumpers are made from a light weight, yet highly durable material which can be easily replaced if damaged. The large, wide opening doors make access to all seats very easy. Rear seat passengers have more leg room than before due to the newly designed front seat backs. When the doors have been closed and the ignition turned on, the seat belts are automatically moved towards the driver and front passenger by belt guides, and can therefore be fastened more easily. After being fastened, the guides return to their rest position. This sports car like coupe was designed with the driver and passengers in mind at all times. Extra effort was made to reduce excess noise. Double door seals and a bulkhead between engine room and passenger compartment were incorporated to keep noise levels down so that conversation between all occupants can be carried on without raising your voice, even during high speed driving. Dashboard layout was improved with new instrument clus-

ters to reduce driver stress, and include switches and levers that are obvious in their function. Instruments can be read at a glance, by day or by night. The new five litre V-8 engine has improved fuel consumption by 18%, and the transmission incorporates an RPM reduction system at idle, which in combination with the modified engine camshaft and improved fuel atomization, reduces fuel consumption at idle by more than 40%. With the shorter wheel base of the coupe it has a turning radius of only 37.8 feet, which makes it much easier to maneuver in tight situations. The 500SEC incorporates four wheel independent suspension and four disc brakes for positive, fade free braking. Engine produces 231hp at 5250RPM which gives this coupe a top speed of 225 km/h., and a fuel consumption rate of 15.2 K per litre. Once again, Mercedes-Benz has produced a vehicle greatly sought after by car lovers the world over.

* * *

Traditionell die schönste Form der Mercedes-Technik: das neue Coupé. Traditionsgemäss baut Mercedes-Benz den Sondertypen eines Automobils, das sich vor anderen Modellreihen durch hohe Individualität auszeichnet: das Coupé. Diese Individualität beweist sich in der Fähigkeit, in Technik und Ästhetik jeweils den aktuellen Höchststand der Automobiltechnik zu repräsentieren. Technische Grundlage der beiden neuen Modelle 380 SEC und 500 SEC ist das Konzept der S-Klasse - der entlastende Komfort, die Sicherheit und Leistung einer Mercedes-Reiselimousine. Hinzu kommt der ästhetische Reiz des Coupés, seine Bauform von sportlichem klarem Zuschnitt, ohne Schnörkel und überflüssigen Zierat. Das Mercedes-Coupé

verkörpert den seltenen Typus eines kultiviert sportlichen Automobils. Denn seine Sportlichkeit bedeutet nicht Verzicht auf Komfort und Sicherheit. Vielmehr kommen seine sportlichen Fahrzeugattribute zu allen jenen Eigenschaften, die jeden Mercedes auszeichnen. Dieser unverwechselbare Charakter des neuen Coupés teilt sich Fahrer und Beifahrer in einer Weise mit, die sich schwer beschreiben, aber unbeschwert erleben lässt. Die Tradition, Automobile dieses Formats zu bauen, ist für Mercedes-Benz zu keiner Zeit Selbstzweck gewesen, sondern stets eine Verpflichtung für die Zukunft: Das neue Coupé ist ein Fahrzeug, mit dem man eine Strecke seines Weges auf die anspruchsvollste Weise zurücklegen kann. Dieses, im Windkanal getestete Coupé hat einen Cw-Wert von 0.34. Die Frontpartie ist keilförmig abgeschrägt, die Vorderwandsäulen sind strömungsgünstig geneigt und gestaltet. Die Dachlinie fällt nach hinten ab, das Heck ist keilförmig angehoben. Dies bewirkt einen geringeren Auftrieb an der Vorderachse und noch grössere Fahrstabilität, die Fahrzeugbegrenzungen sind noch deutlicher im Blickfeld des Fahrers. Zwei grosse, sich weit öffnende Türen ermöglichen einen bequemen Einstieg. Nach Schliessen der Türen werden die Gurte automatisch mit Gurtbringern an Fahrer und Beifahrer herangebracht. Technische Daten: Leichtmetall V8 Motor mit mechanischer Benzineinspritzung, kontaktlos gesteuerte Transistorzündung, elektronischer Leerlaufdrehzahlregelung und hydraulischem Ventilspielausgleich. 170 kW (231 PS) bei 4750/min. 4-Gang-Wandler-Automatic. Radstand 2845mm, Höhe 1406mm, Breite 1828mm, Länge 4910mm, Wendekreis 11,53 m. Verbrauch 15,2 Liter/100 km, bei 90 km/h, 9,1 Liter, bei 120 km/h 11,4 Liter. Tankinhalt 90 Liter.



★ Study the instructions and photographs before commencing assembly.
 ★ Use glue sparingly. Use only enough to make a good bond. Apply cement to both parts to be joined.
 ★ Before cementing plated parts, remove plating with a knife, etc. from the surface to which cement is applied.
 Color numbers denoted in instructions are available in Tamiya Acrylic Paints & Tamiya Paint Markers.
 ★ Vor Beginn die Bauanleitung studieren und den Nummern nach die Bauteile zusammenbauen bzw. zusammenkleben.
 ★ Teil vor dem Kleben zusammenhalten und auf richtigen Sitz achten. Kleine Teile hält man mit Pinzette fest.
 ★ Tesafilm, Pinzette, Messer, eine kleine Feile und Gummiringe erleichtern die Arbeit und das Bauen.
 Dieses Zeichen zeigt die Farbe und Farbnnummer der Tamiya Acryl-Farben & Tamiya Paint Markers.

1 Assembly of Engine Zusammenbau des Motors

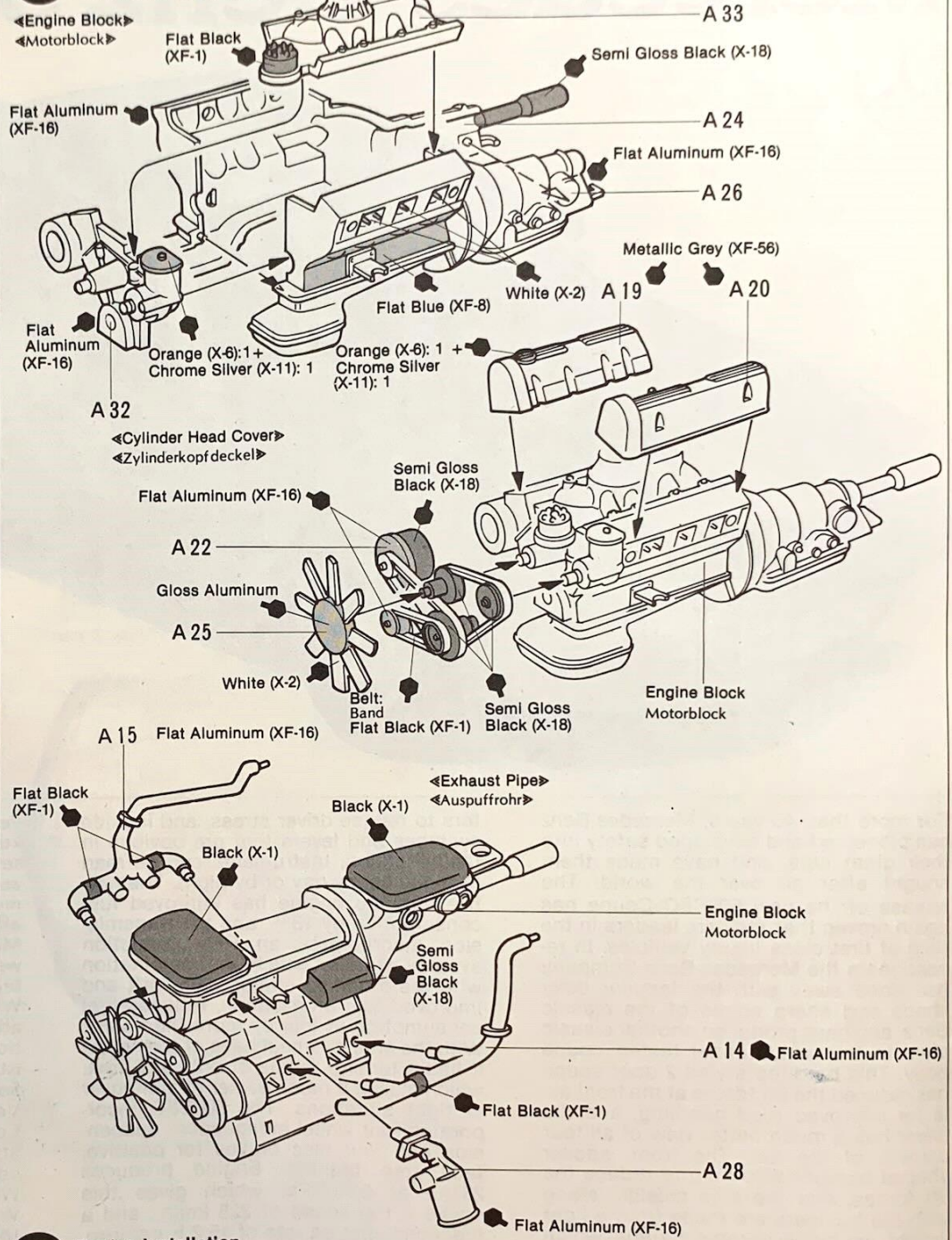

1 <<Completed Engine>> <<Kompletter Motor>>

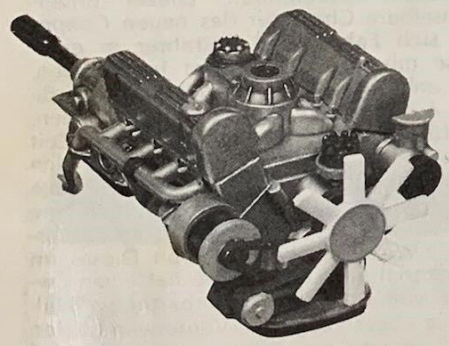

2 Engine Installation Einbau des Motors

★ Do not break parts from sprue, but cut off carefully with a pair of pliers.
 ★ Bauteile nicht vom Spritzling abbrechen, vorsichtig abschneiden oder abwickeln.

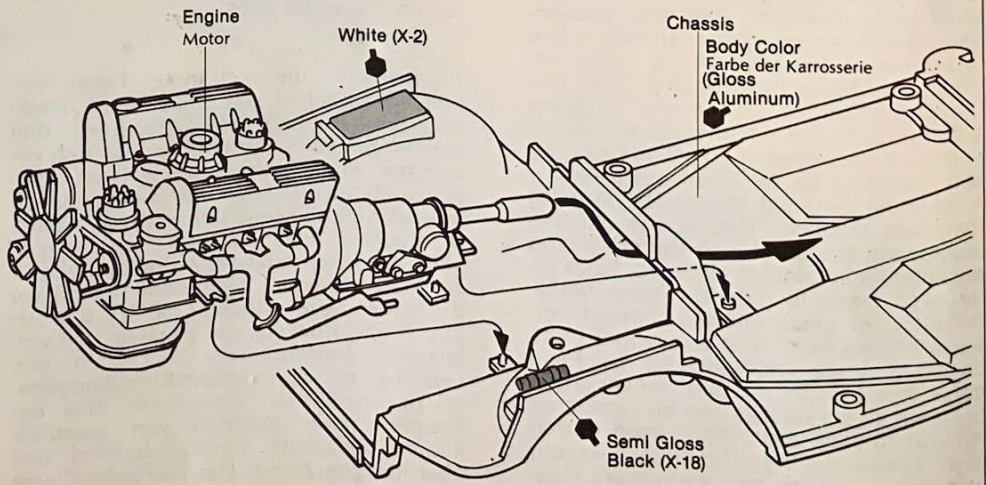
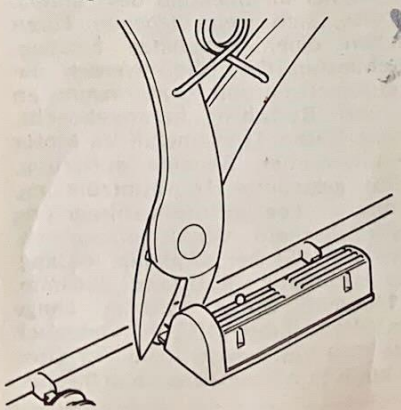

3 <<Attached Radiator>>
<<Eingebauter Kühler>>

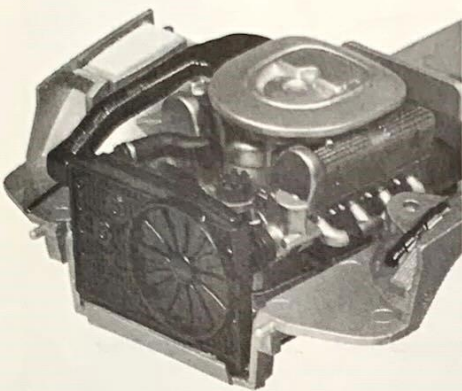

3 Attaching Radiator
Einbau des Kühlers

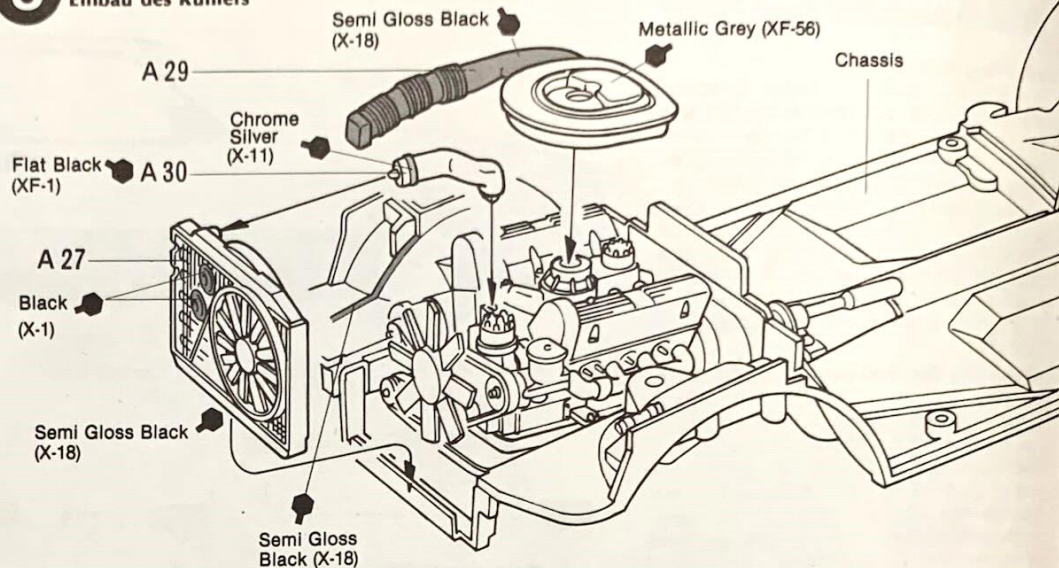

4 <<Assembly of Front Disc Brake>>
<<Vorderscheibenbremse>>

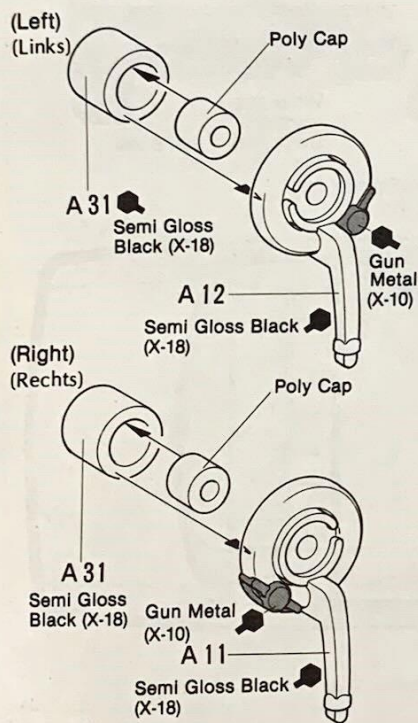

4 Front Suspension
Vordere Achsaufhängung

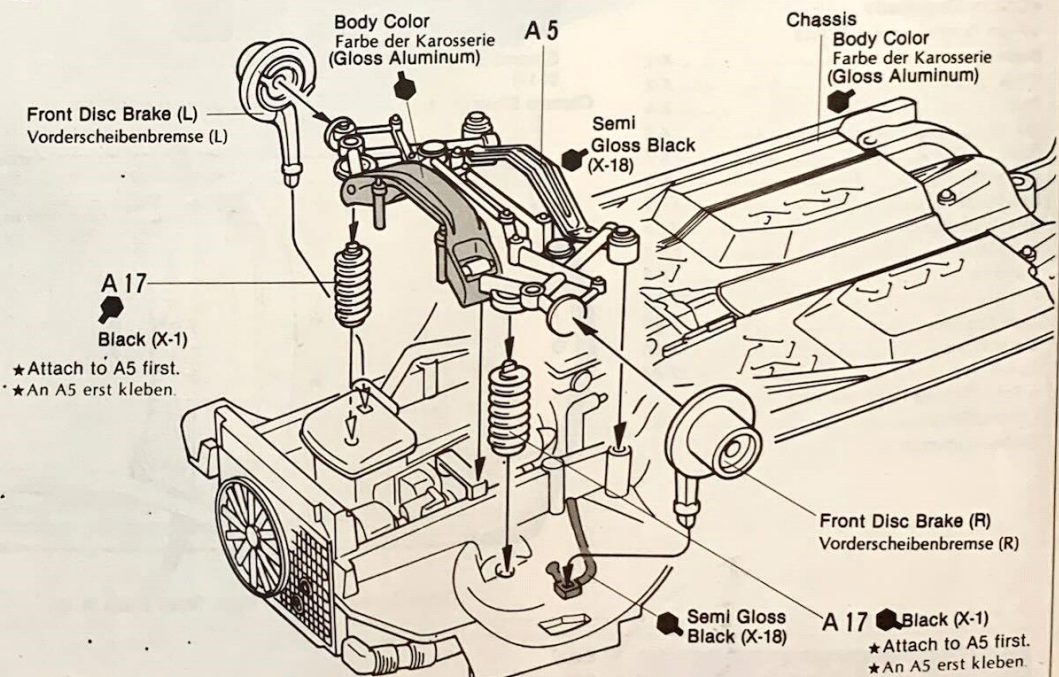

5 Attaching Rear Sub Frame
Hinterer Nebenrahmen

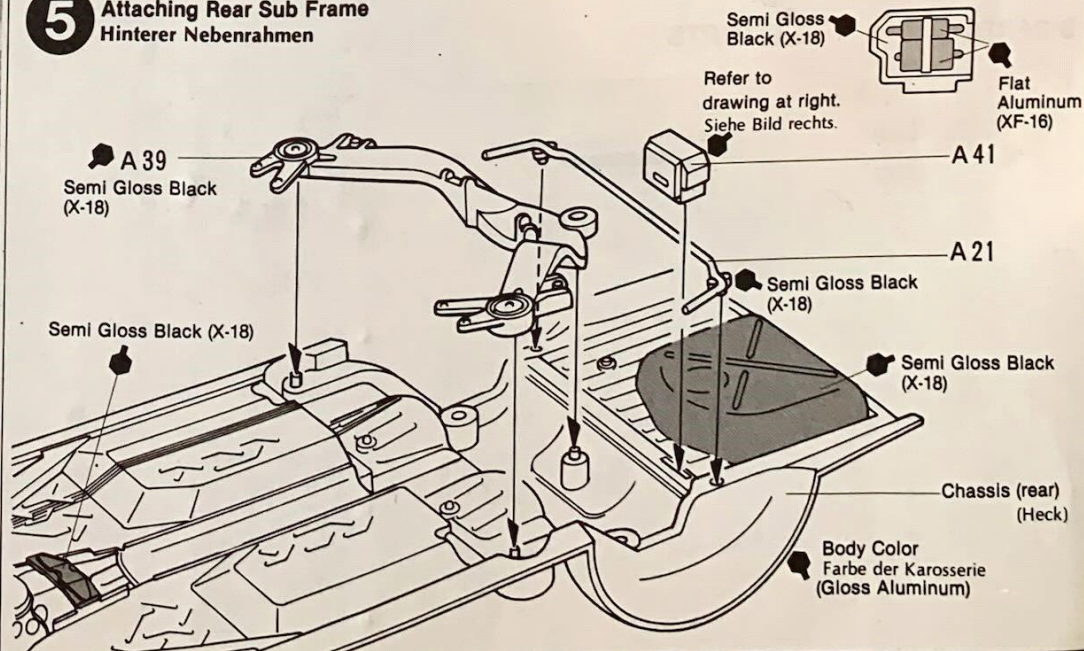

<<Painting of A41>>
<<Bemalung von A41>>

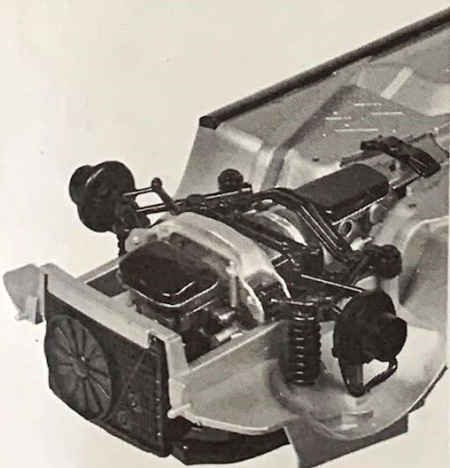

Tamiya Acrylic Paints
Need precise colour matching?
Try the new Tamiya acrylic
paints. Engineered by modelers for model-
er's use. The final cover for the finest mod-
els. Insist on Tamiya for perfect results.

8 «Attached Wheels»
«Eingebaute Räder»



6 Assembly of Wheels
Zusammenbau der Räder

«Wheel» ★ Make 4 sets.
«Räder» ★ 4 Sätze machen.

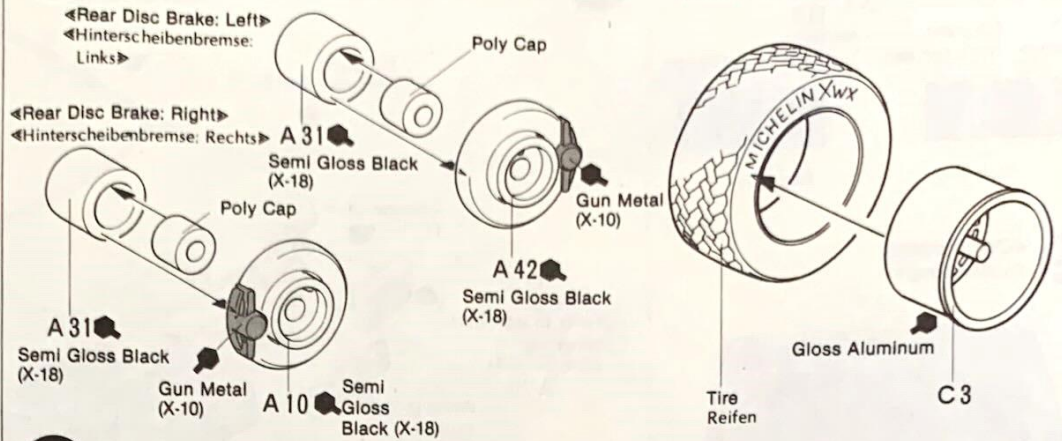

7 Rear Suspension
Hintere Achsaufhängung

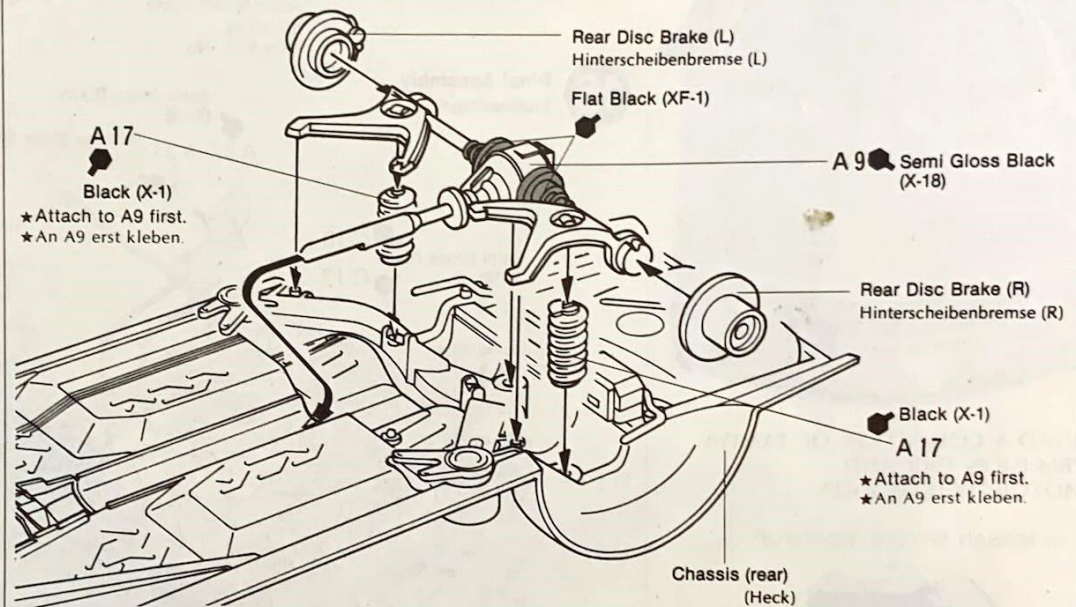

8 Attaching Wheels
Einbau der Räder

★ Snap wheels into place as shown.
★ Nicht kleben, nur eindrücken.

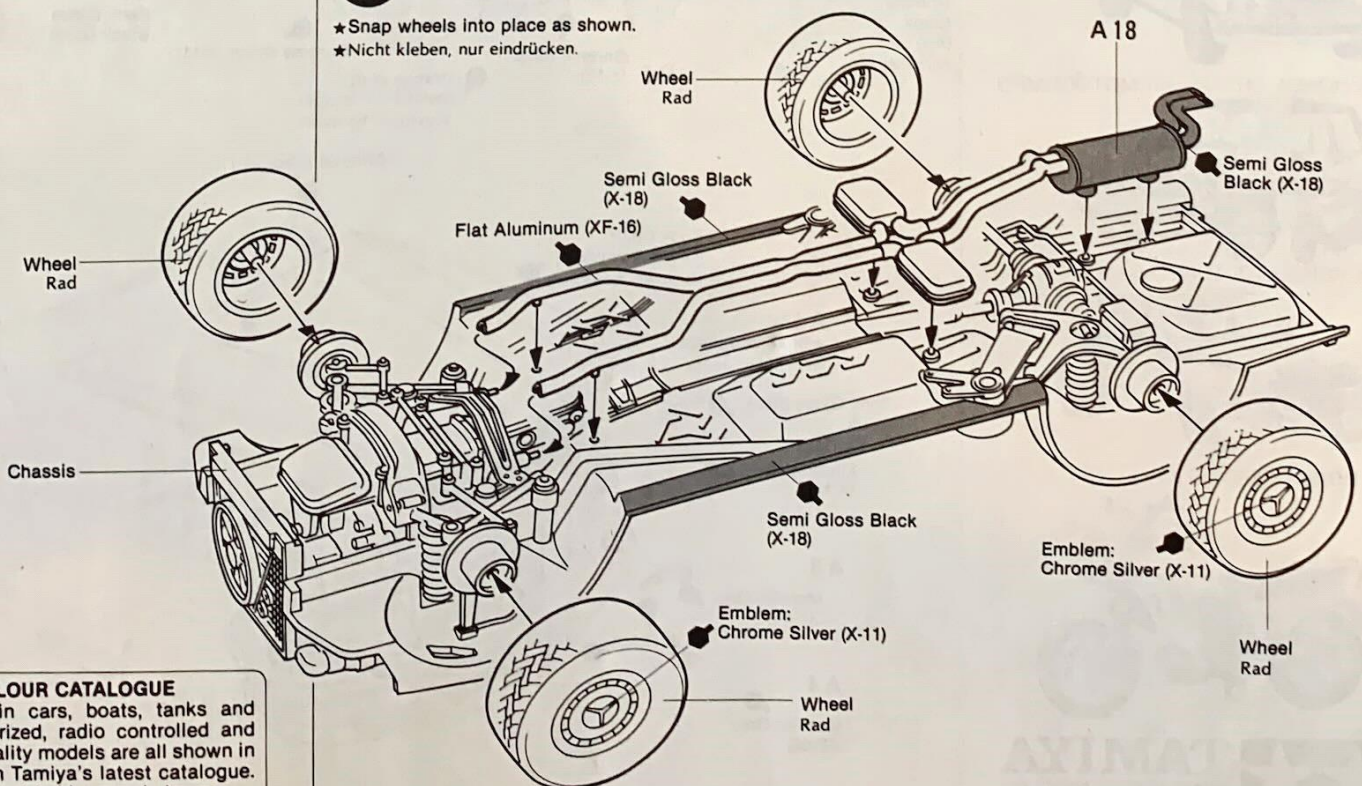

TAMIYA COLOUR CATALOGUE
The latest in cars, boats, tanks and ships. Motorized, radio controlled and museum quality models are all shown in full colour in Tamiya's latest catalogue. At your nearest hobby supply house.

«Body & Interior Colors»

Choose colors referring to diagram below and painting instructions on page 8. Coloring shown in each step is based on a car painted silver.

Body Color	Room
Gloss Aluminum	Flat Blue + Light Sea Grey
Blue	Flat Black + Light Sea Grey
White	Flat Black + Light Sea Grey
Black	Flat Black + Light Sea Grey
Beige	Flat Brown + Desert Yellow
Gold	Flat Brown + Desert Yellow

11 «Painting of Seats»
«Bemalung der Sitze»

(Driver's Seat)
(Fahrsitz)

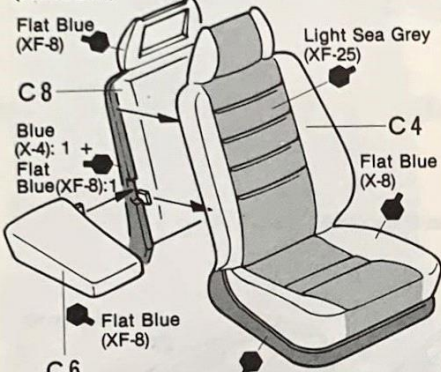

(Passenger Seat)
(Beifahrersitz)

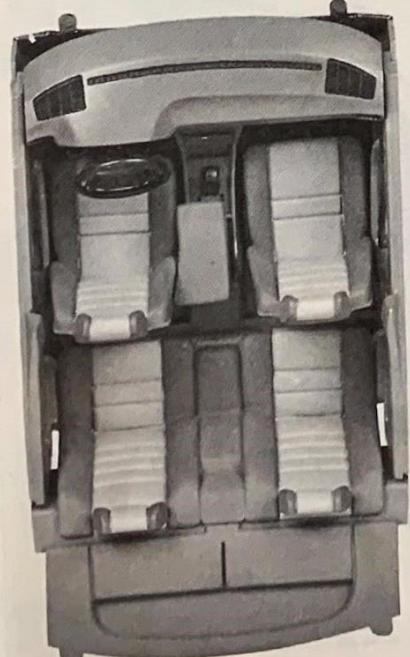

9 Assembly of Dashboard
Zusammenbau des Armaturenbretts

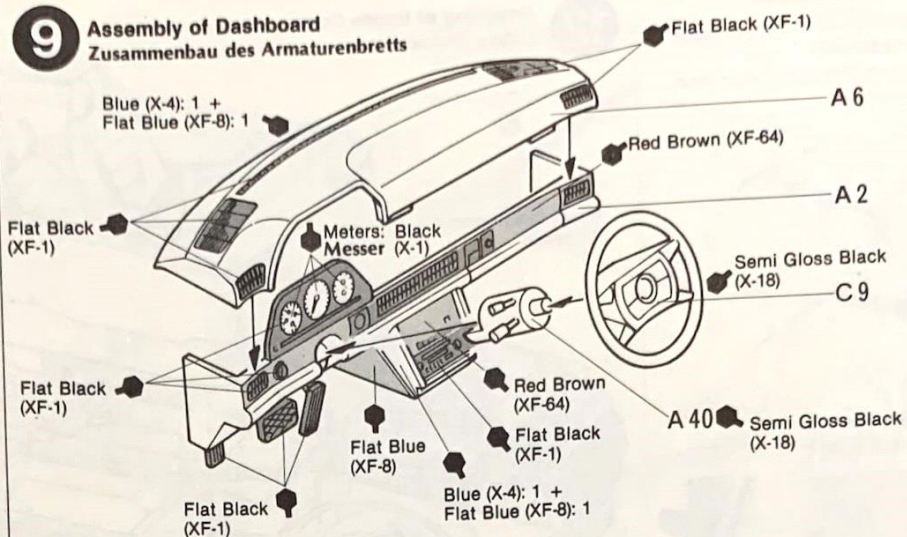

10 Assembly of Interior Parts
Inneneile

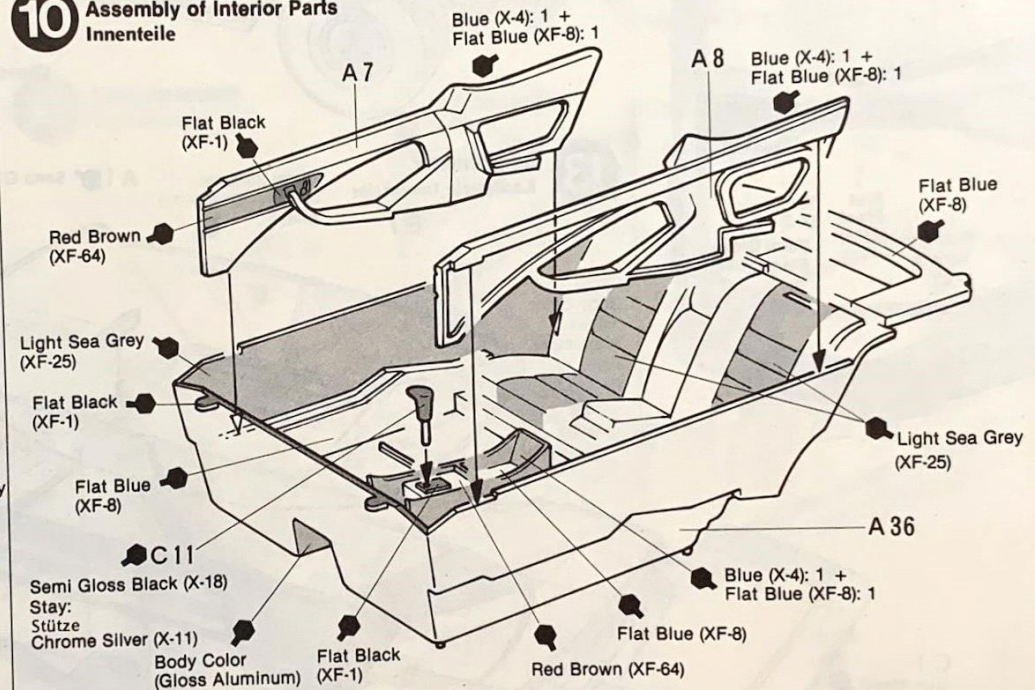

11 Attaching Seats
Einbau der Sitze

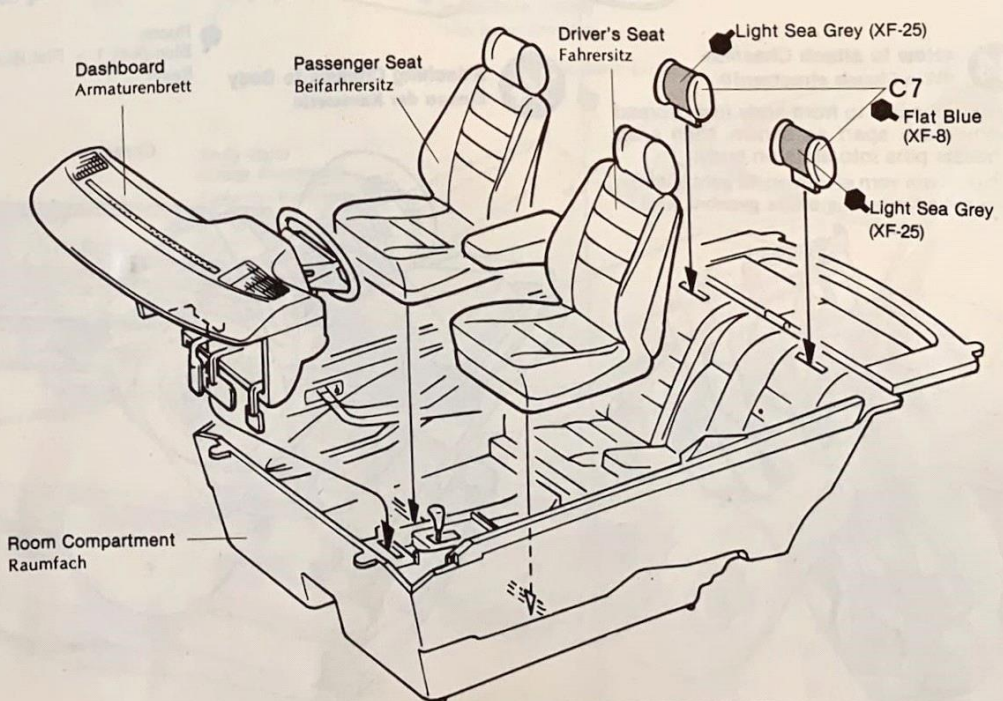

13 «Painting of Body»
«Bemalung der Karosserie»

Apply overall painting of the body prior to commencing assembly.

Zuerst Karosserie bemalen oder besprühen, dann erst weiterbauen.

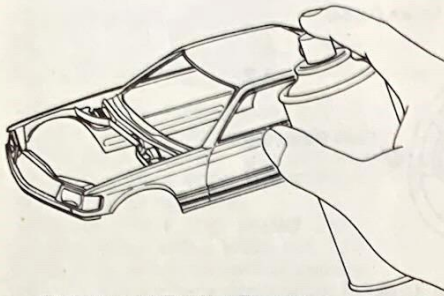

«Painting of Engine Room»
«Bemalung des Motorraums»



12 Attaching of Inside Parts
Einbau des Innenteils

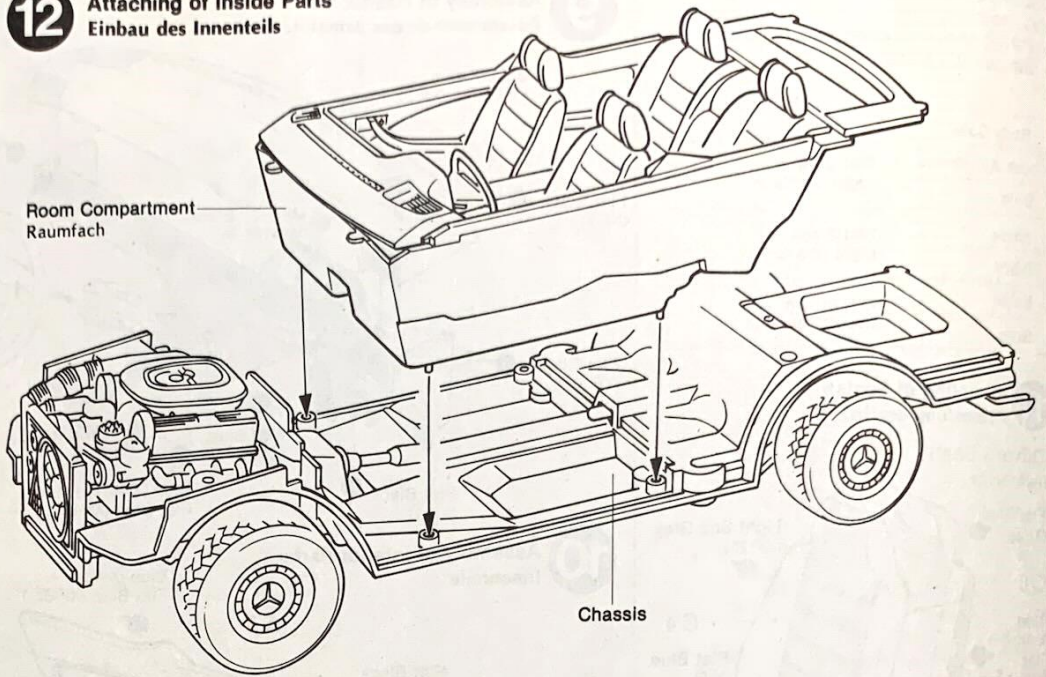

13 Body Interior
Karosserie Innenteile

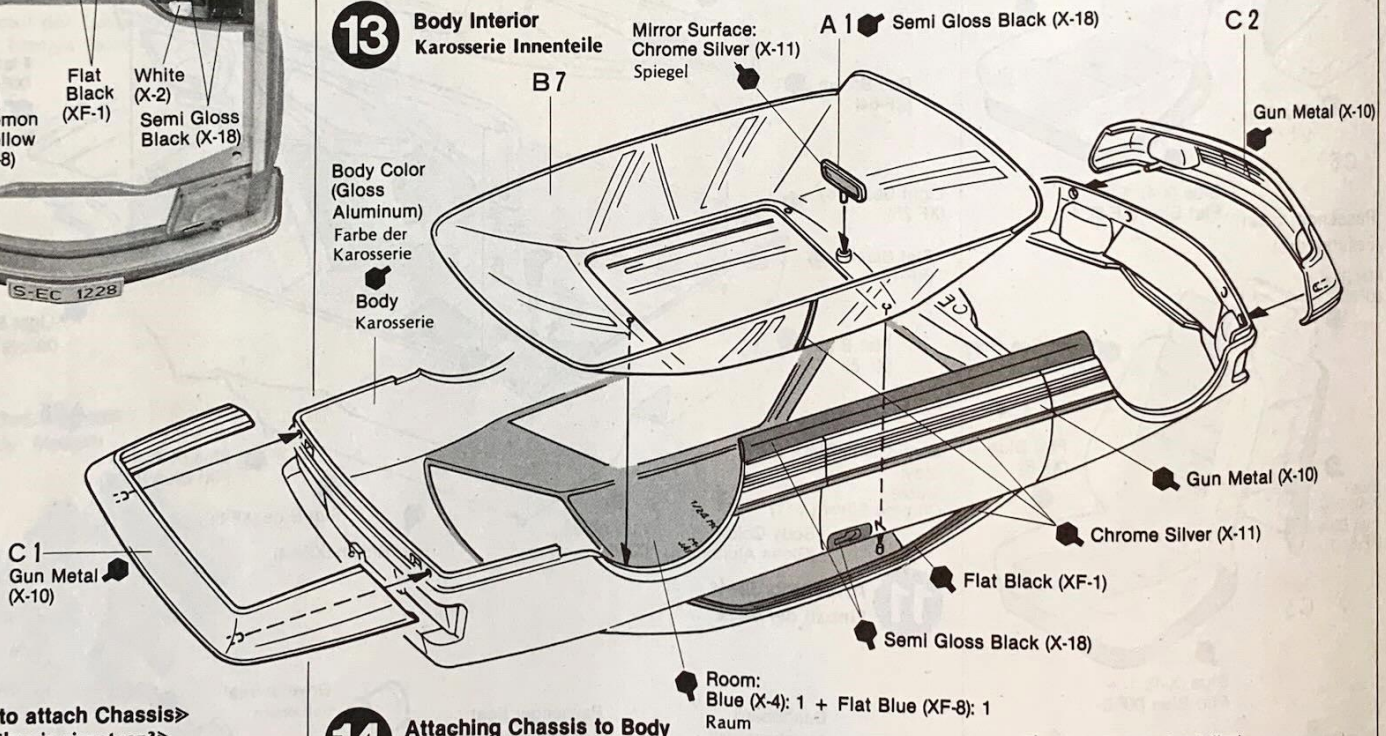

14 «How to attach Chassis»
«Wie Chassis einsetzen?»

Insert chassis to front body first. Spread body sides apart as shown, then snap chassis pins into slots on body.

Chassis von vorn einsetzen. Es geht leichter, wenn die Karosserie etwas gedehnt wird.

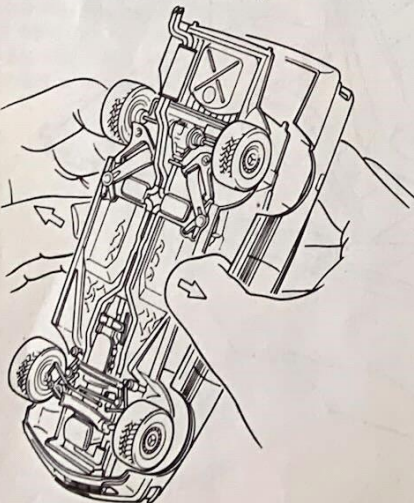

14 Attaching Chassis to Body
Einbau der Karosserie

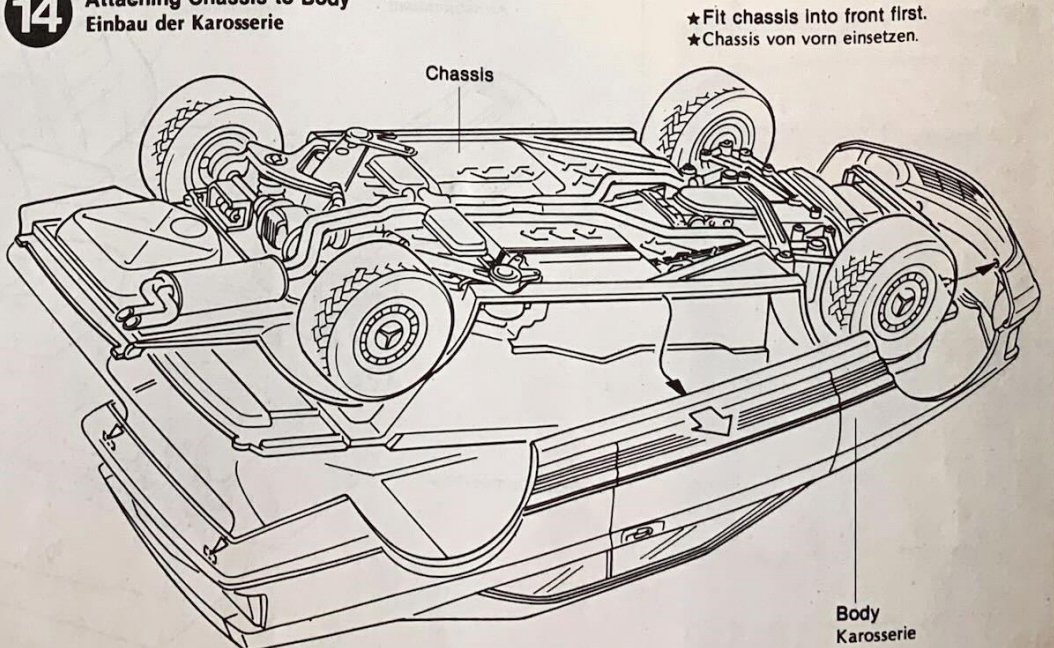

15 <<Painting of Taillights>>
<<Bemalung der Schlussleuchten>>

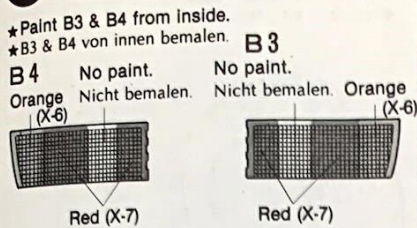

16 <<Completion>>
<<Vollendung>>

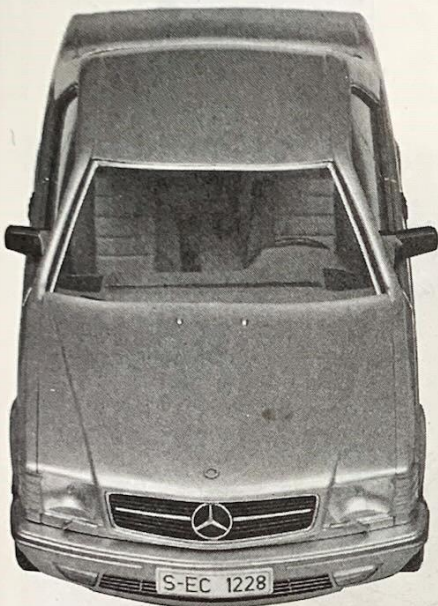

BUILD A COLLECTION OF TAMIYA
PRECISION CAR AND
MOTORCYCLE MODELS

1/24 NISSAN SKYLINE HARDTOP



1/24 HONDA CITY R with MOTOCOMPO



1/24 RENAULT 5 TURBO RALLY



1/6 HONDA CX500 TURBO

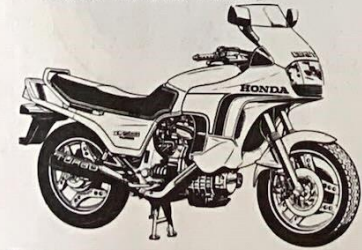

15 Attaching Taillights
Einbau der Schlussleuchten

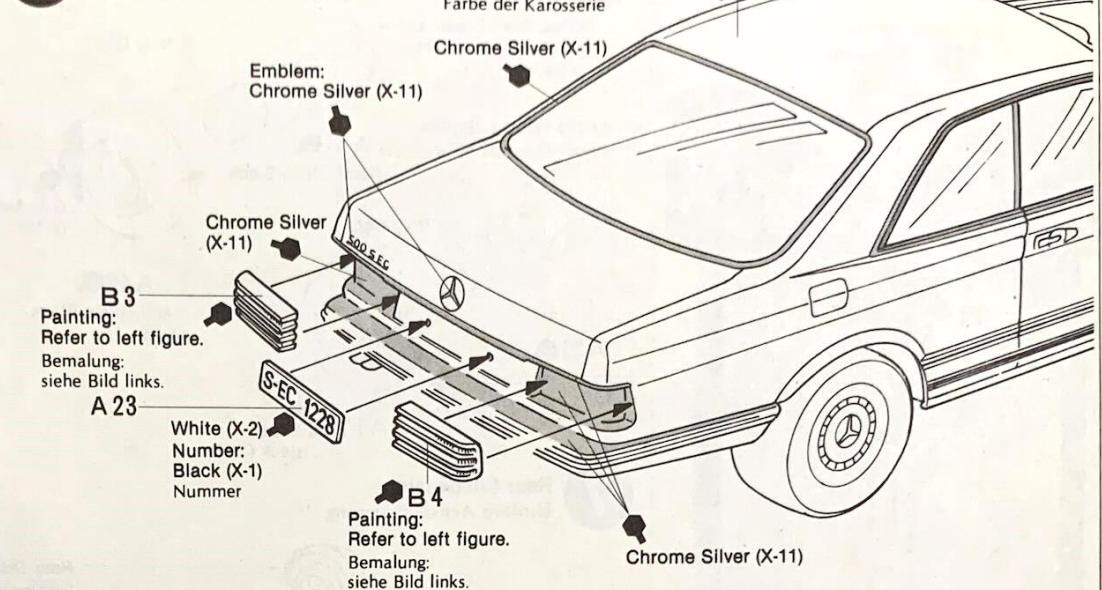

16 Final Assembly
Endmontage

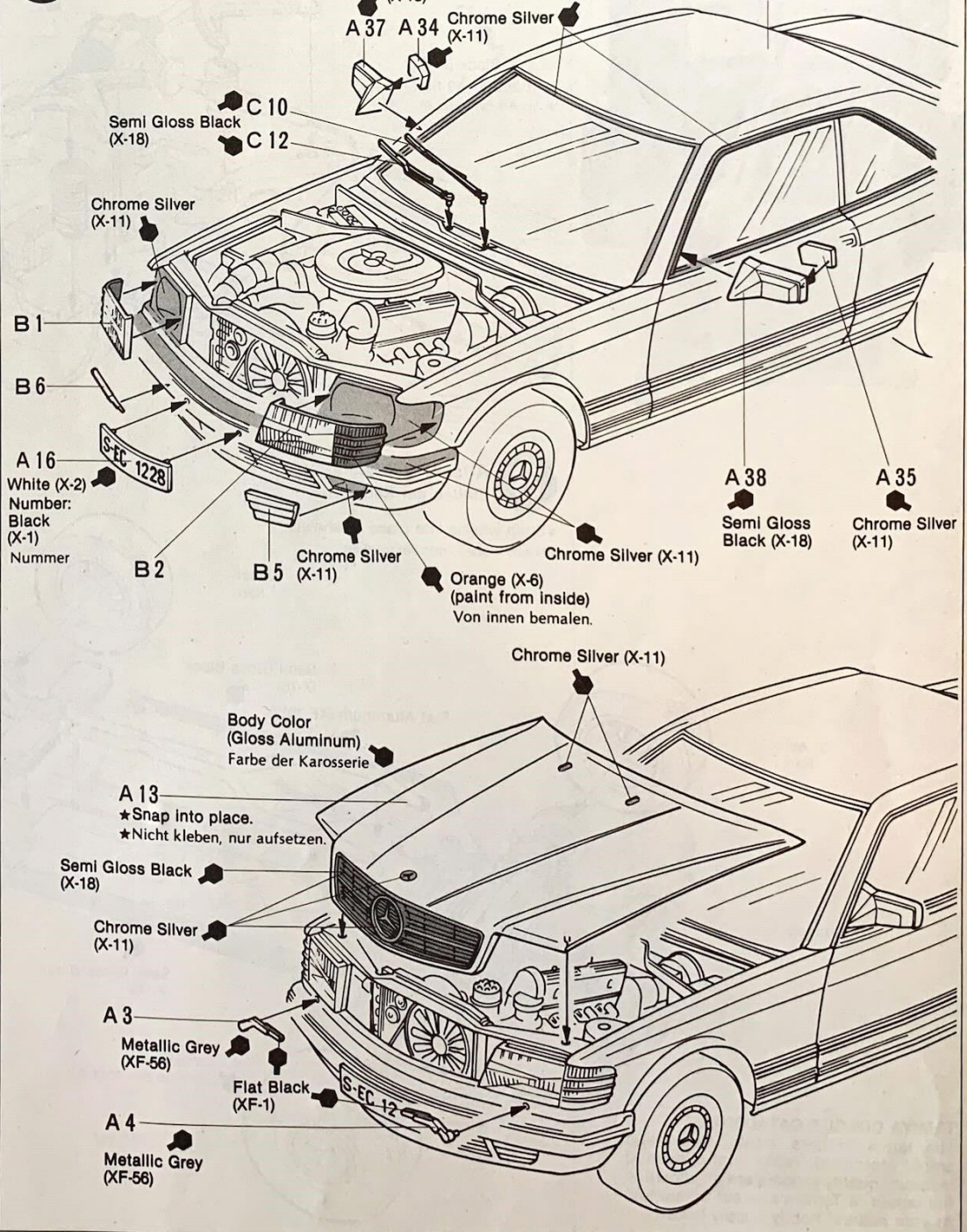

PAINTING

Body Color
(Gloss Aluminum)

«Painting Information»

The 500SEC Coupe is offered in seven standard colors, ten special shades and nine metallic finishes. Box top artwork shows it with the metallic silver/grey body and two tone blue/grey velour interior. Exterior protective side panels and bumpers are a semi gloss silver/black. Interior dashboard, console and door handle areas are highly polished burl walnut. Detail painting is called out during construction and should be done at that time.

«Bemalung des Mercedes Benz 500 SEC»

Das 500 SEC Coupé wird in 7 Standard Farben und in 9 Metallic Ausführungen sowie mehreren Kombinationen, geliefert. Die Kartonbilder zeigen das Coupé in metallic Silber/grauer Karosserie und blau/grauer Velour Inneneinrichtung. Seitenschutzleisten und Stossfänger sind in schwarz/silber Seidenmatt. Instrumentenbrett und Türgriffverkleidungen sind in poliertem Walnussholz. Bemalung der Details siehe Bauanleitung.

«Colors Required»

★ From Tamiya Acrylic Paints

- Black X-1
- White X-2
- Blue X-4
- Orange X-6
- Red X-7
- Lemon Yellow X-8
- Gun Metal X-10
- Semi Gloss Black X-18
- Flat Black XF-1
- Flat Blue XF-8
- Flat Aluminum XF-16
- Light Sea Grey XF-25
- Metallic Grey XF-56
- Red Brown XF-64

★ From Tamiya Paint Markers

- Chrome Silver X-11
- Gloss Aluminum

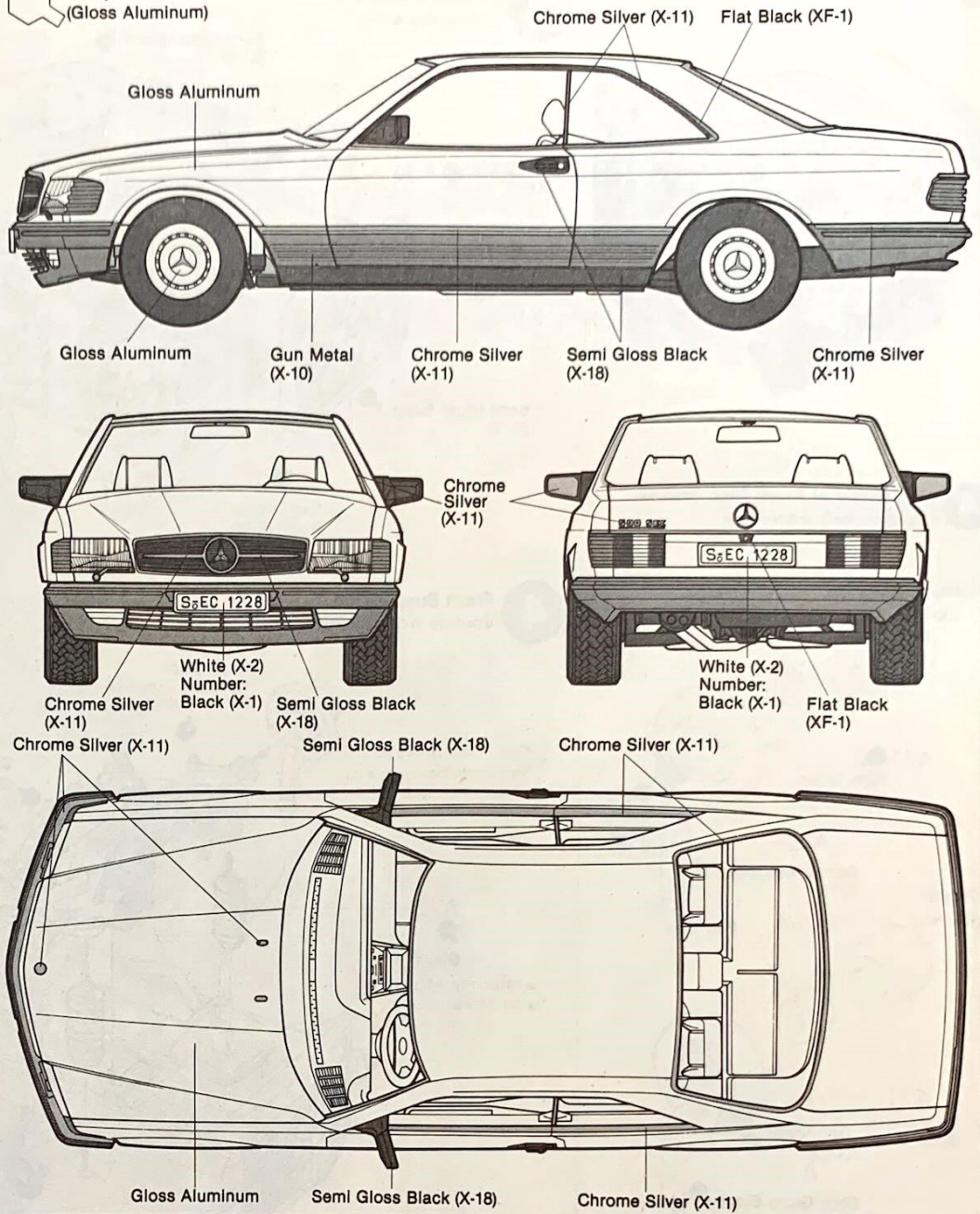

PARTS

Body
Chassis
Tire Bag (Tires, Poly Caps)

B PARTS

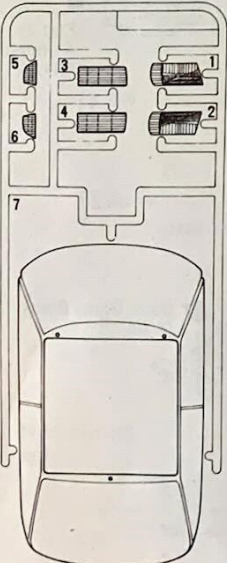

C PARTS

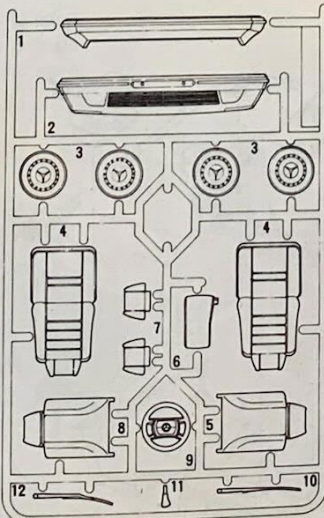

A PARTS

