

**1/24 Super detail engine bay kit
for Hasegawa Mini Cooper**

24T059

USCP



ukrainian scale cars production

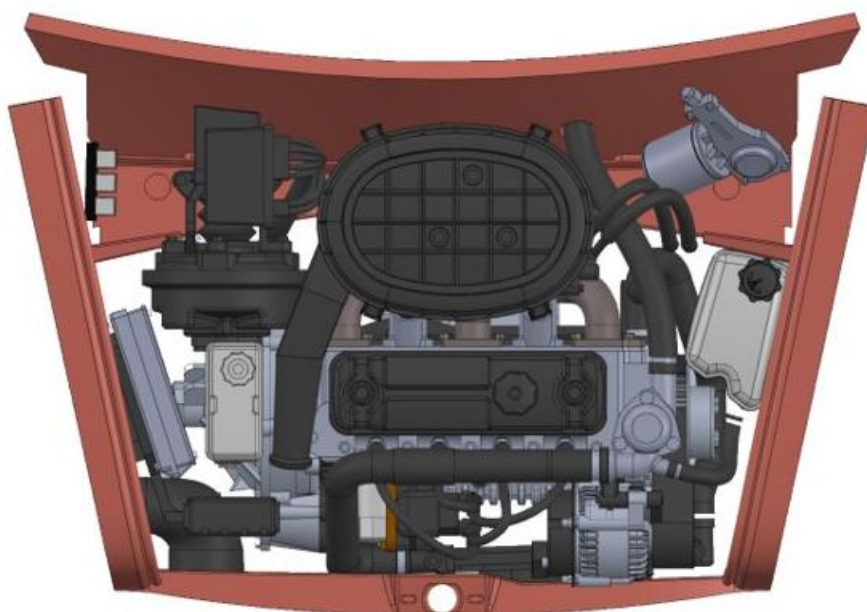

Mini Cooper MPI
Engine Bay set

ASSEMBLY INSTRUCTION

2023

Made in Ukraine

Resin parts:

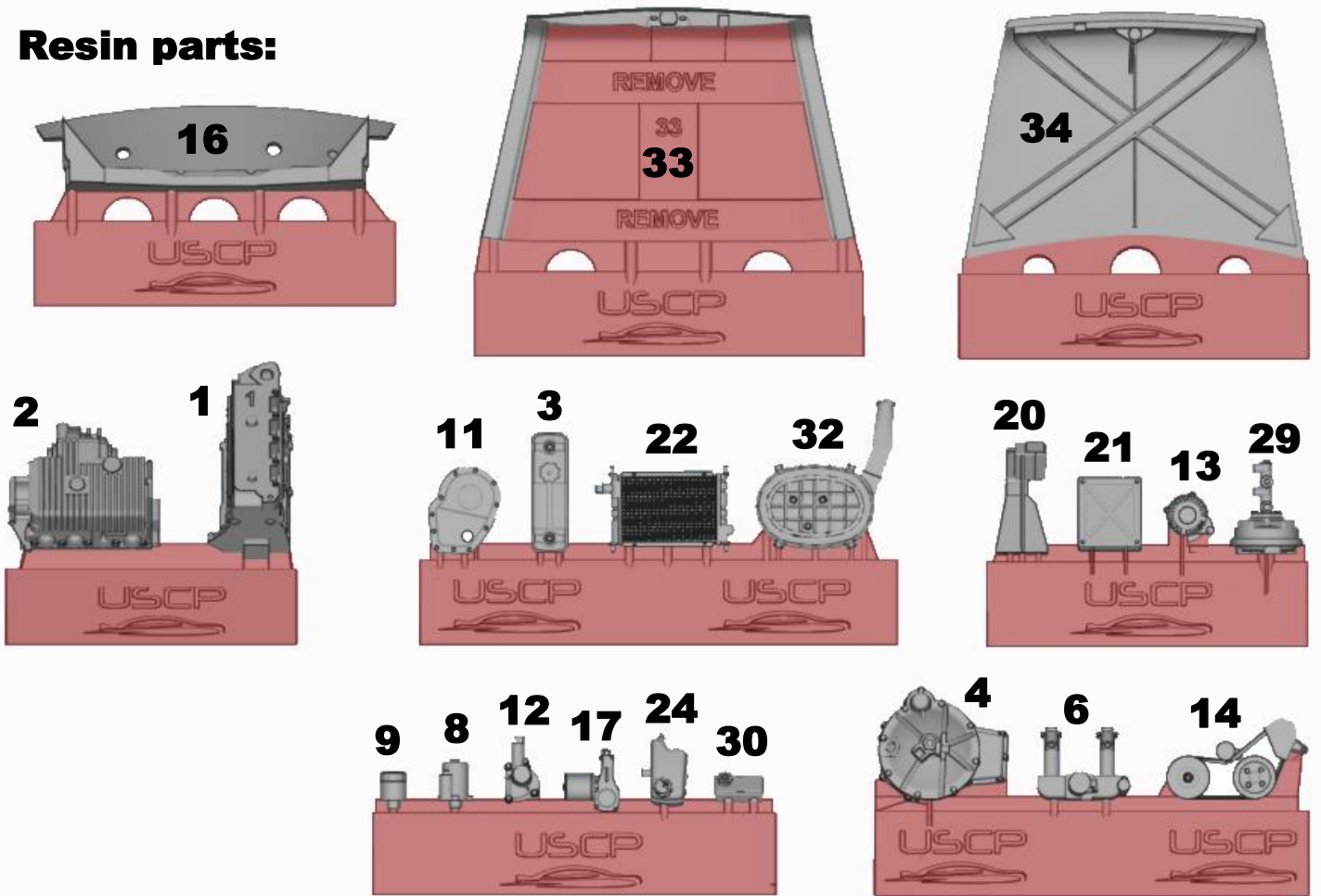

3D printed parts:

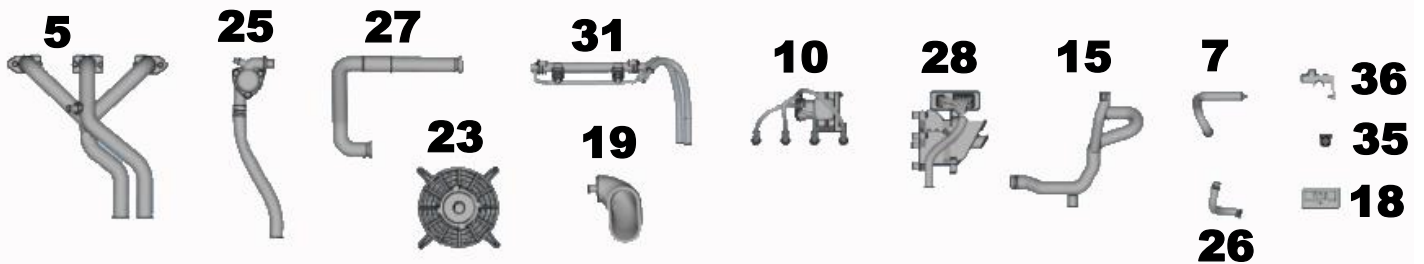

Colors:	F – moon white
A – semi gloss black	G – body color
B – aluminum	H – gloss black
C – steel	or dark green
D – rubber black	
E – exhaust color	

Assemble full engine bay before assembling suspension and interior.

1. Engine block, valve cover, oil pan

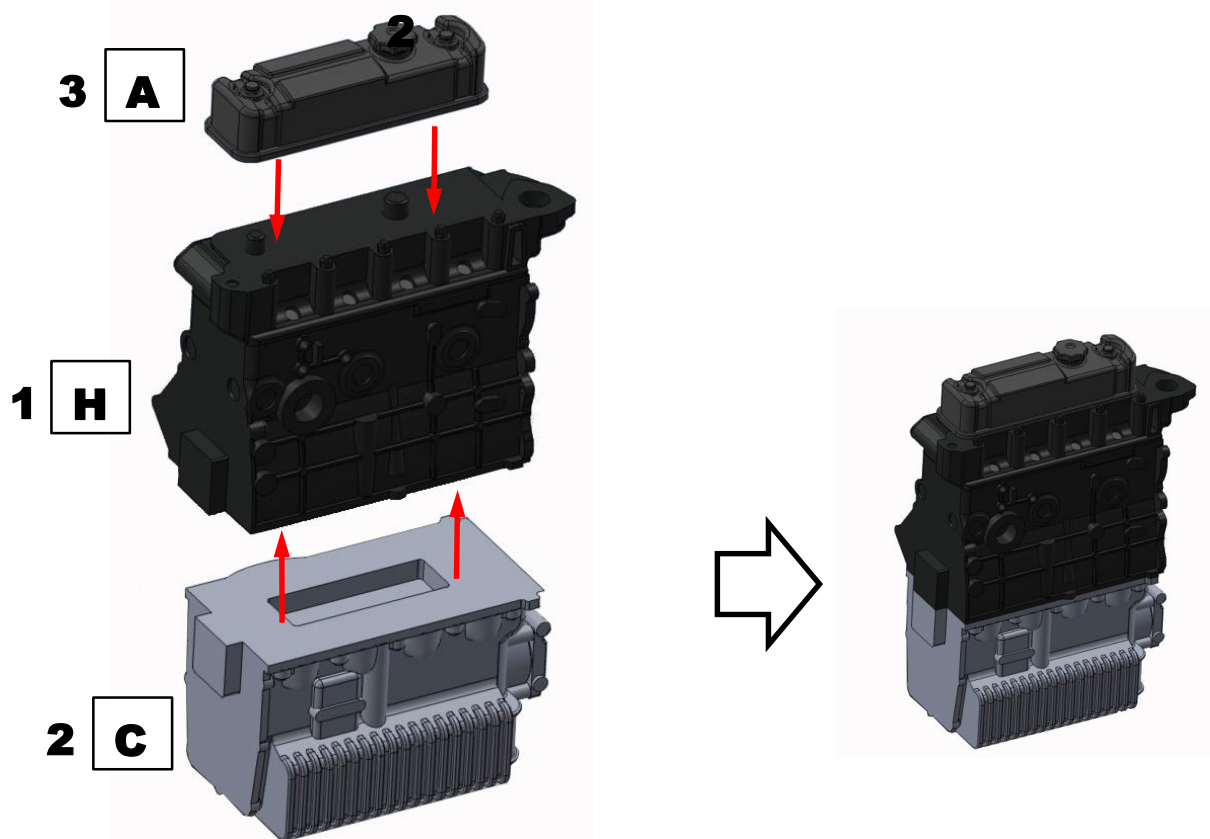

2. Exhaust, intake, clutch

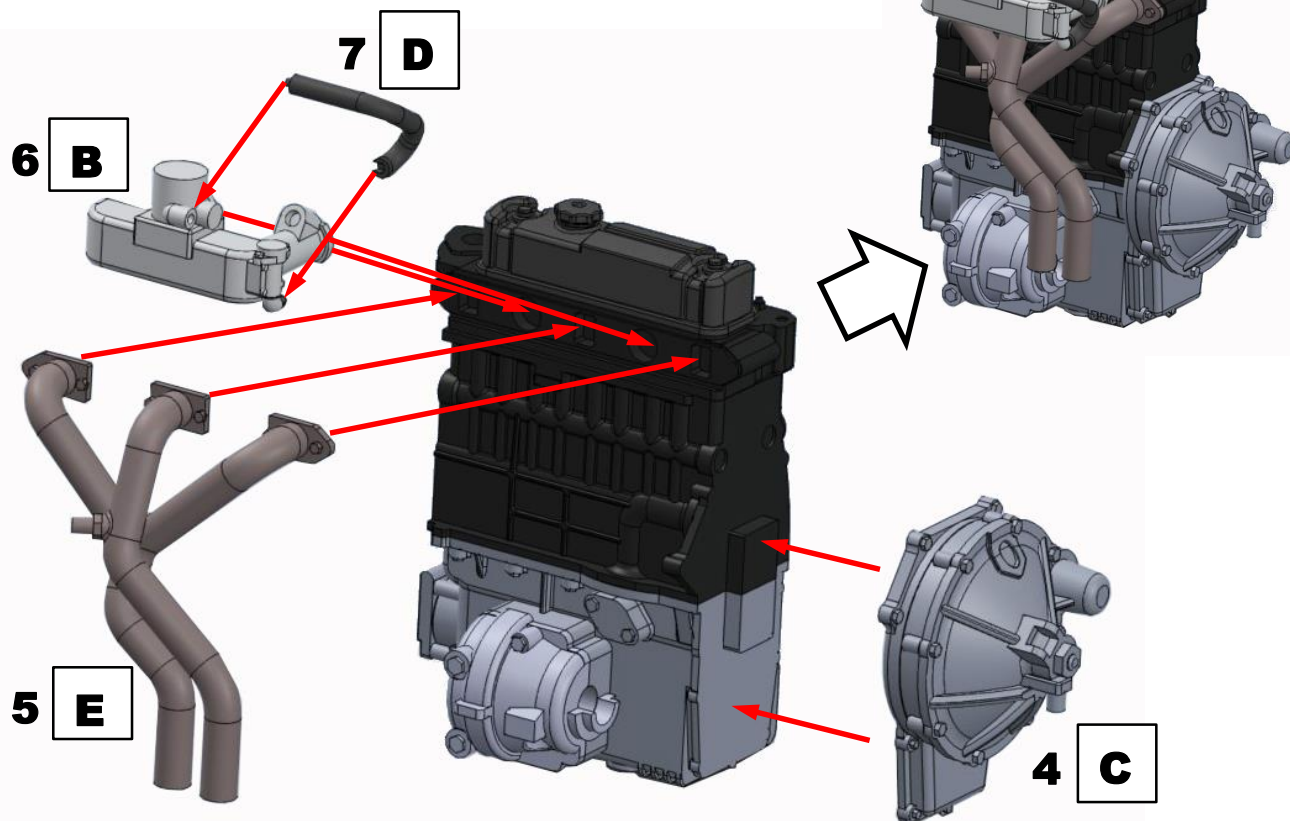

3. Ignition, oil filter, starter, water pump, chain cover

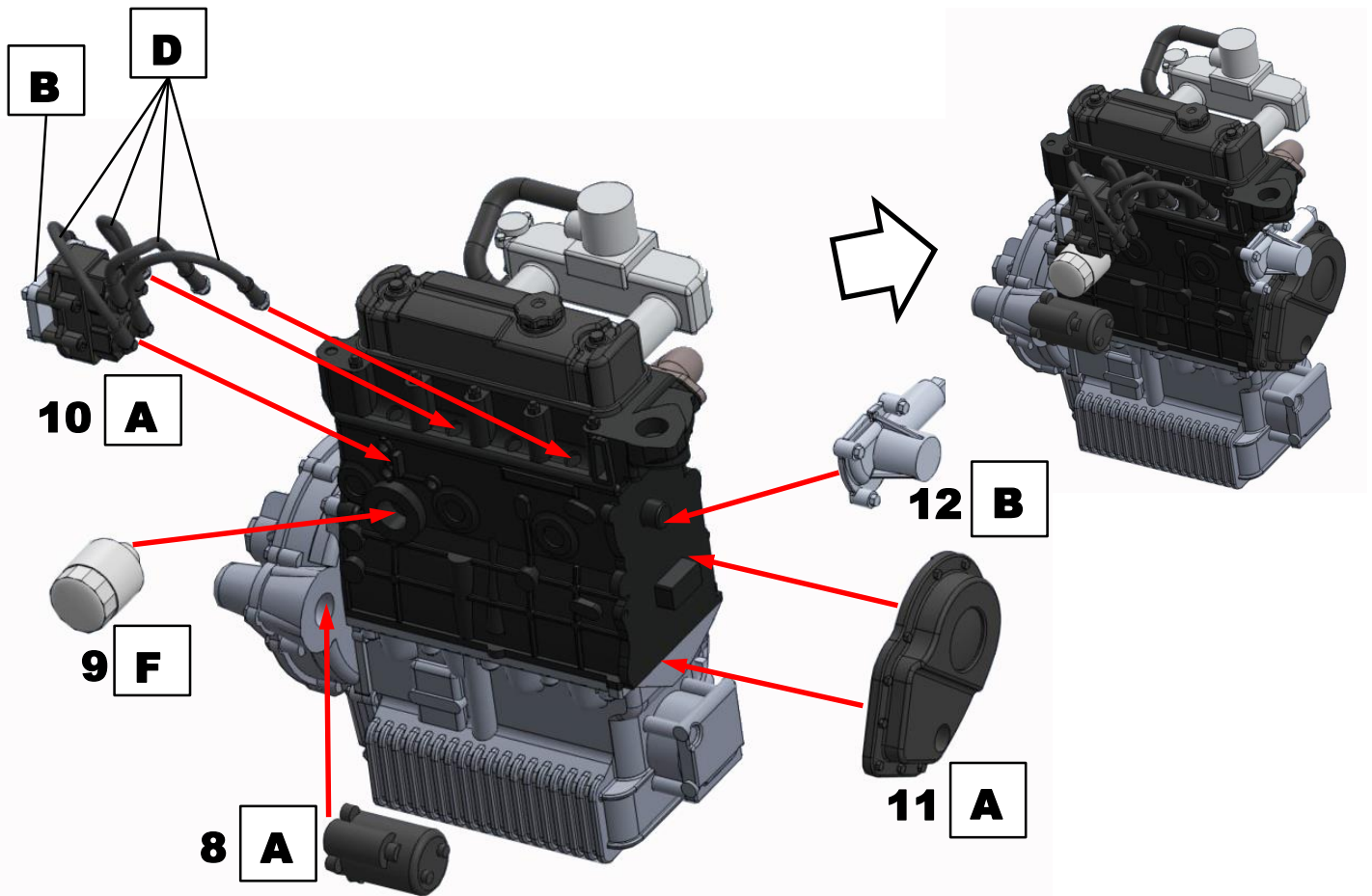

4. Generator, belt, coolant pipe

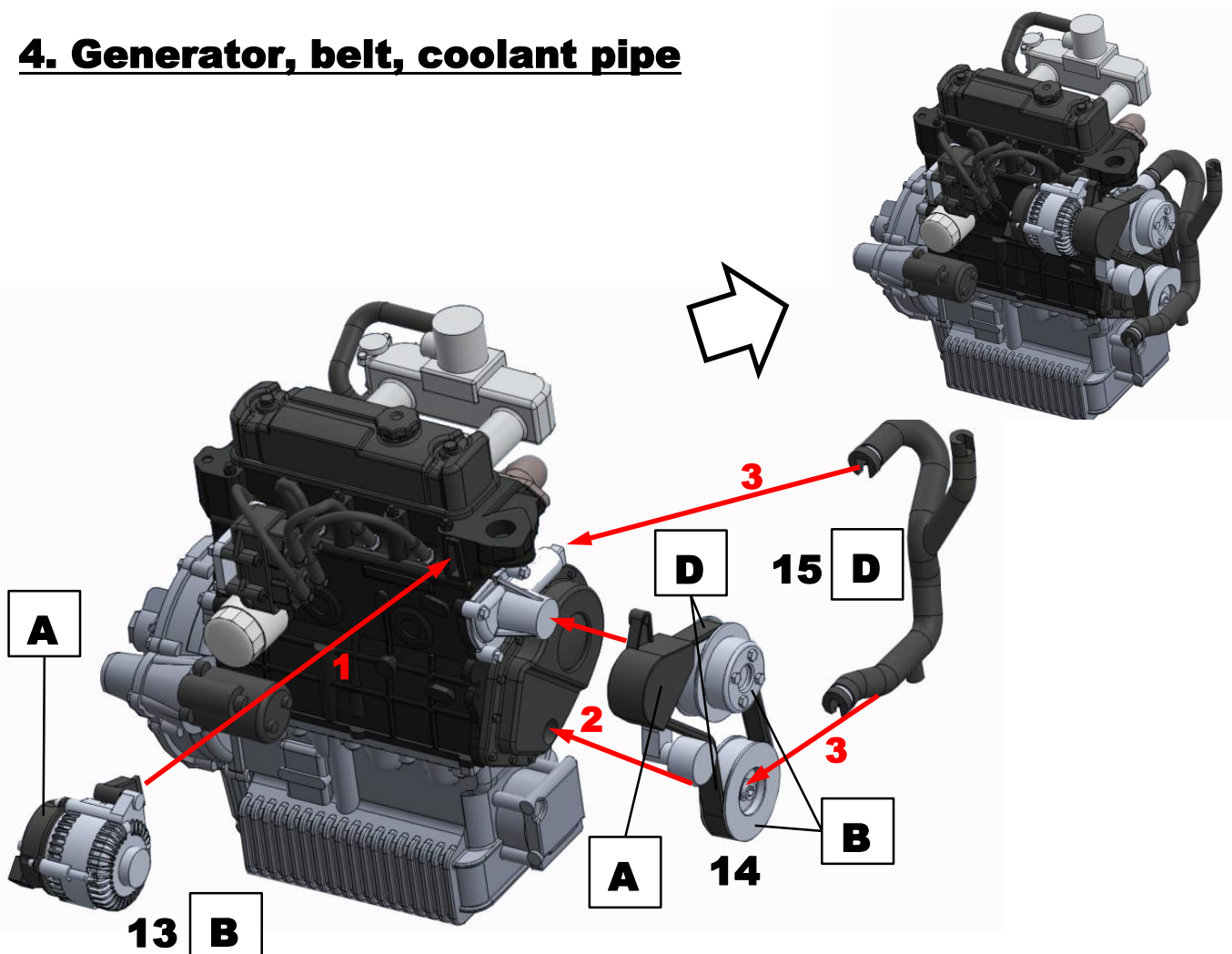

5. Chassis preparation

Cut Hasegawa chassis part (#3) as shown on the picture



Drill 1mm holes in side walls of engine bay:

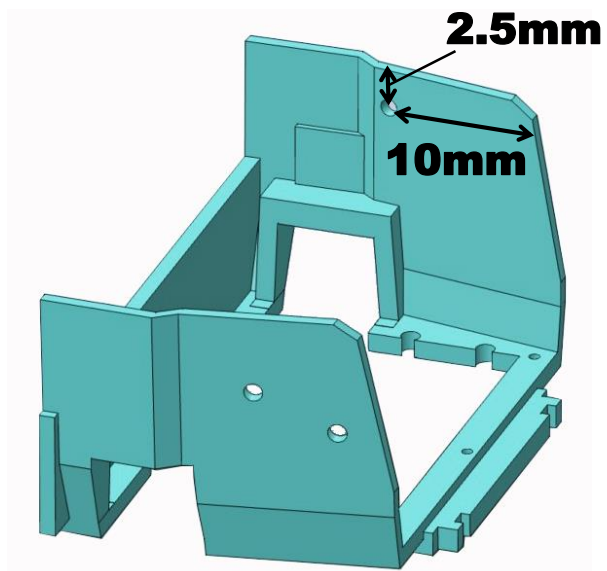
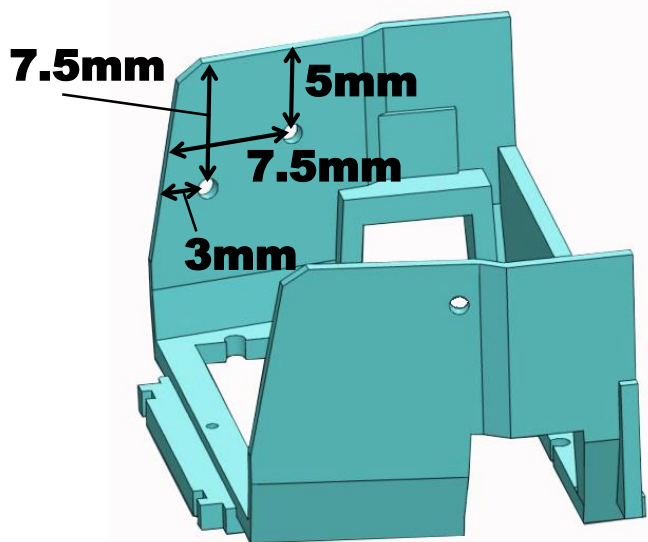

Install resin part #16 as shown on the picture

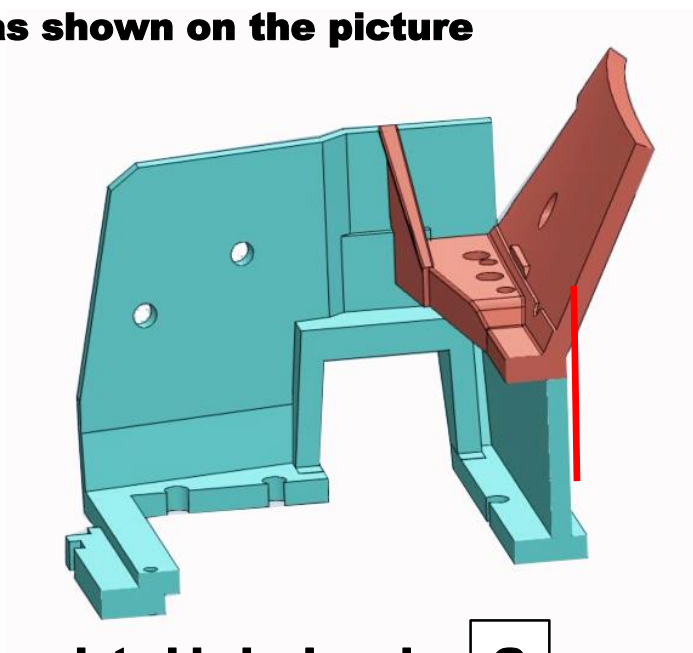

Chassis and engine bay painted in body color

G

6. Engine bay components

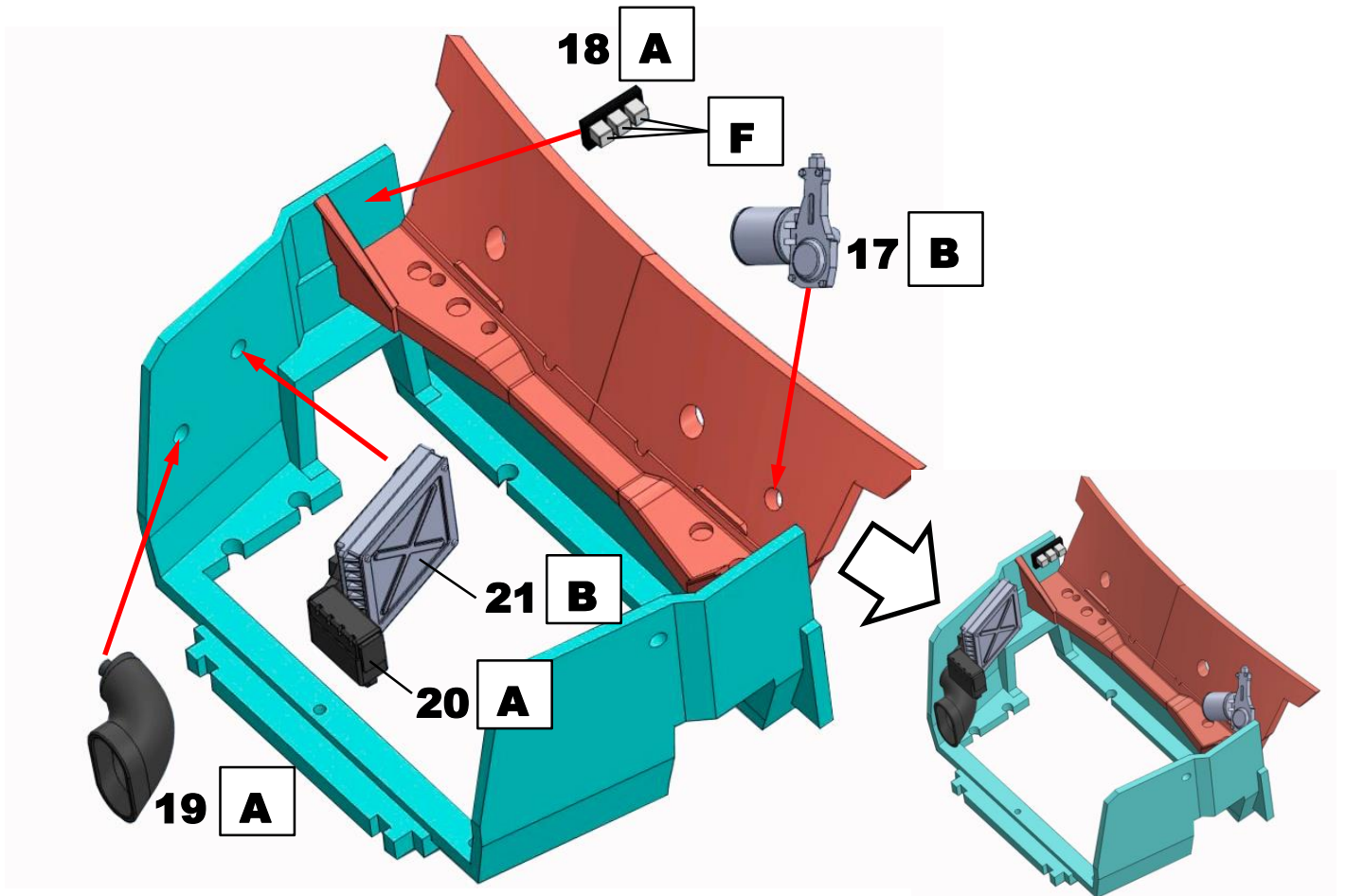

7. Engine installation.

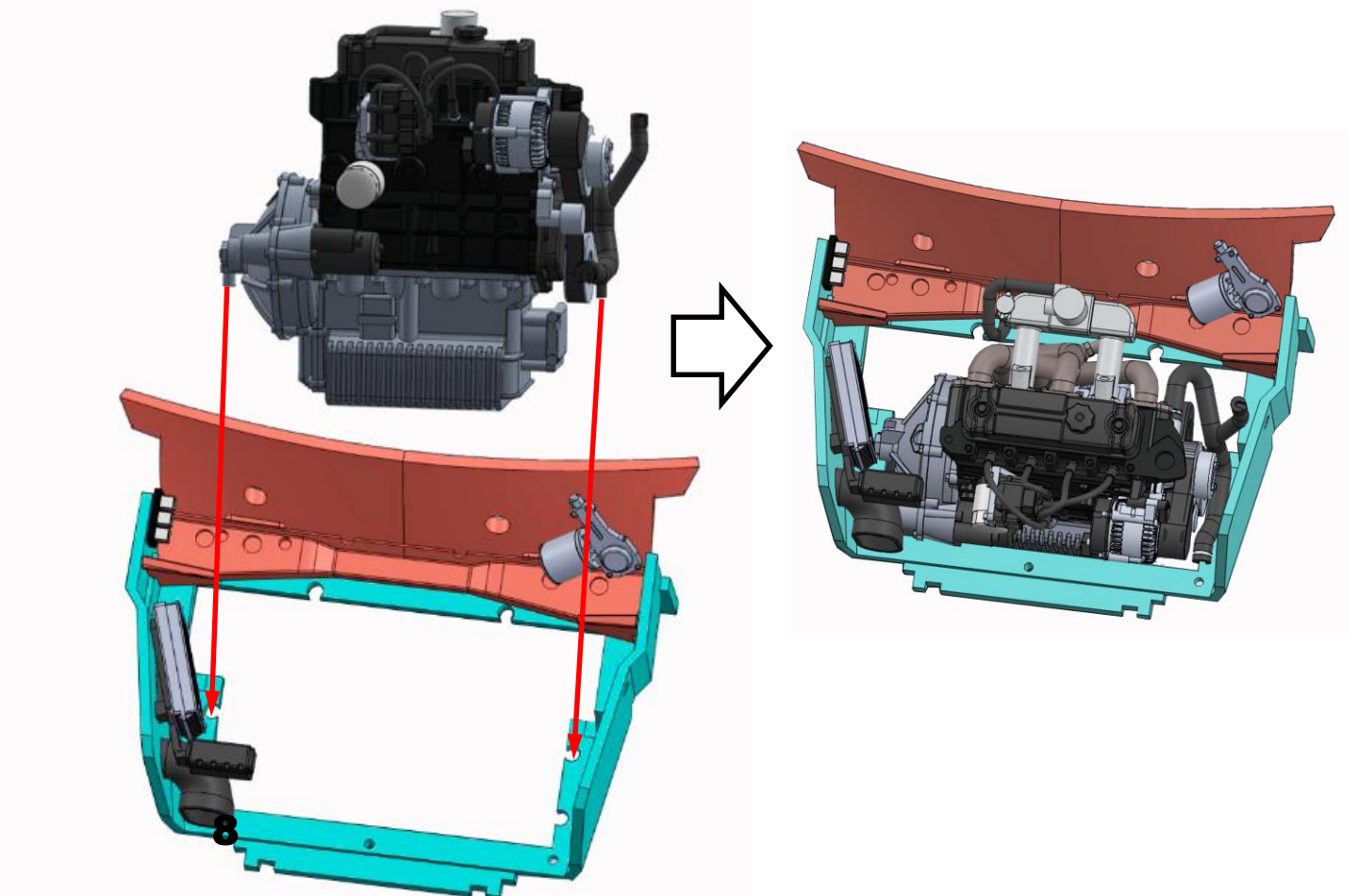

8. Coolant system

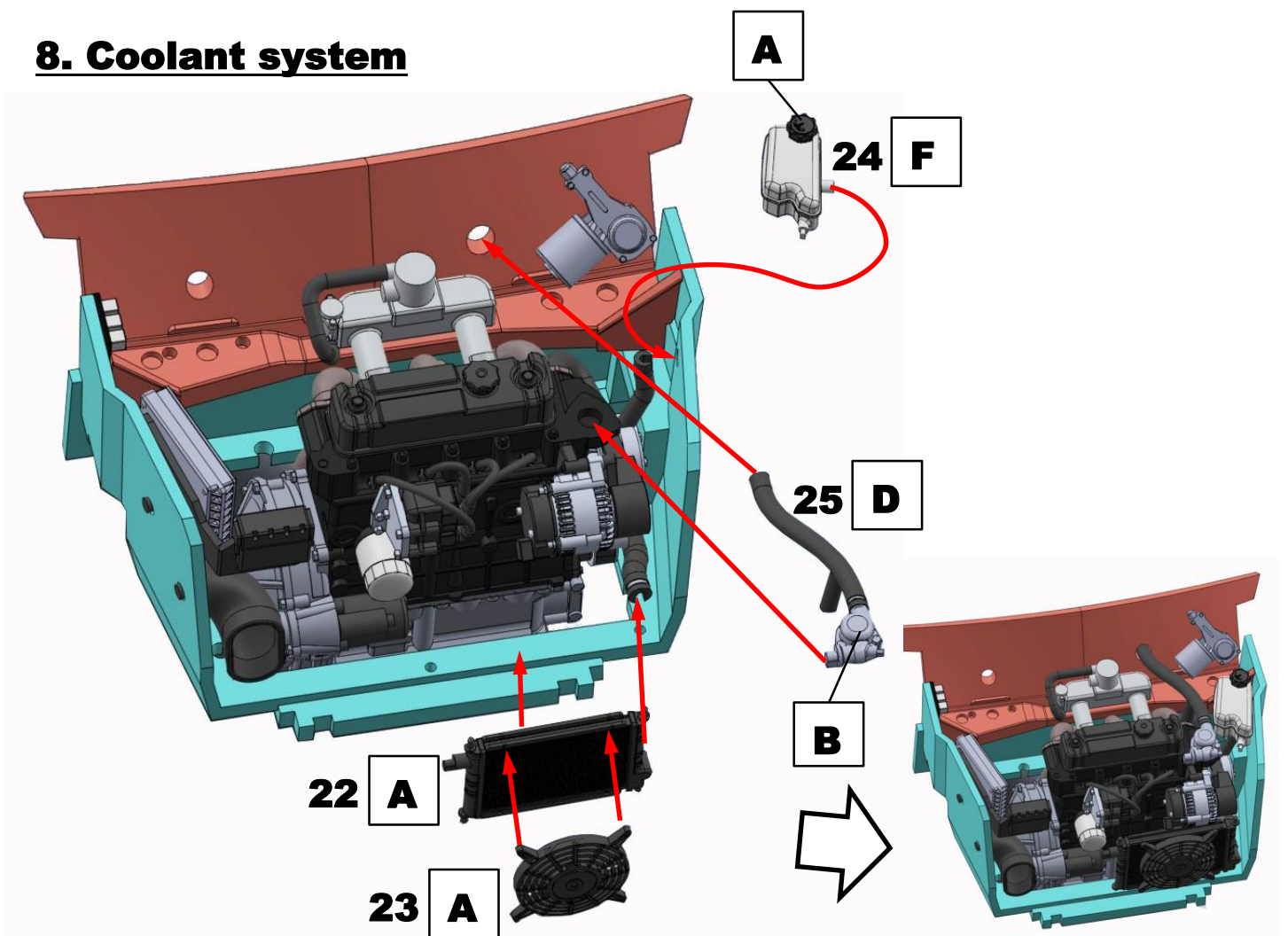

9. Coolant pipes, fuel injection

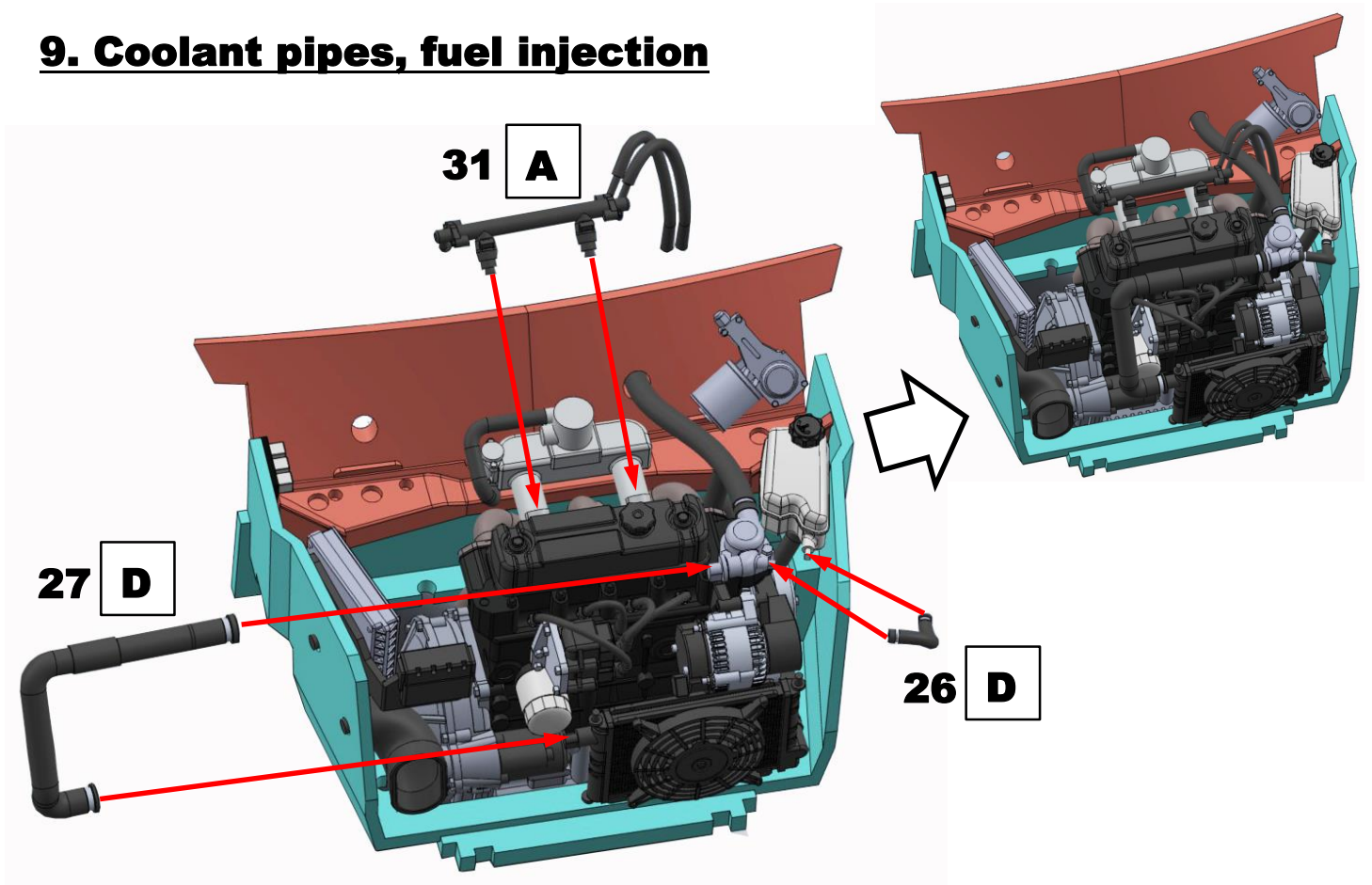

10. Brake cylinder, air filter

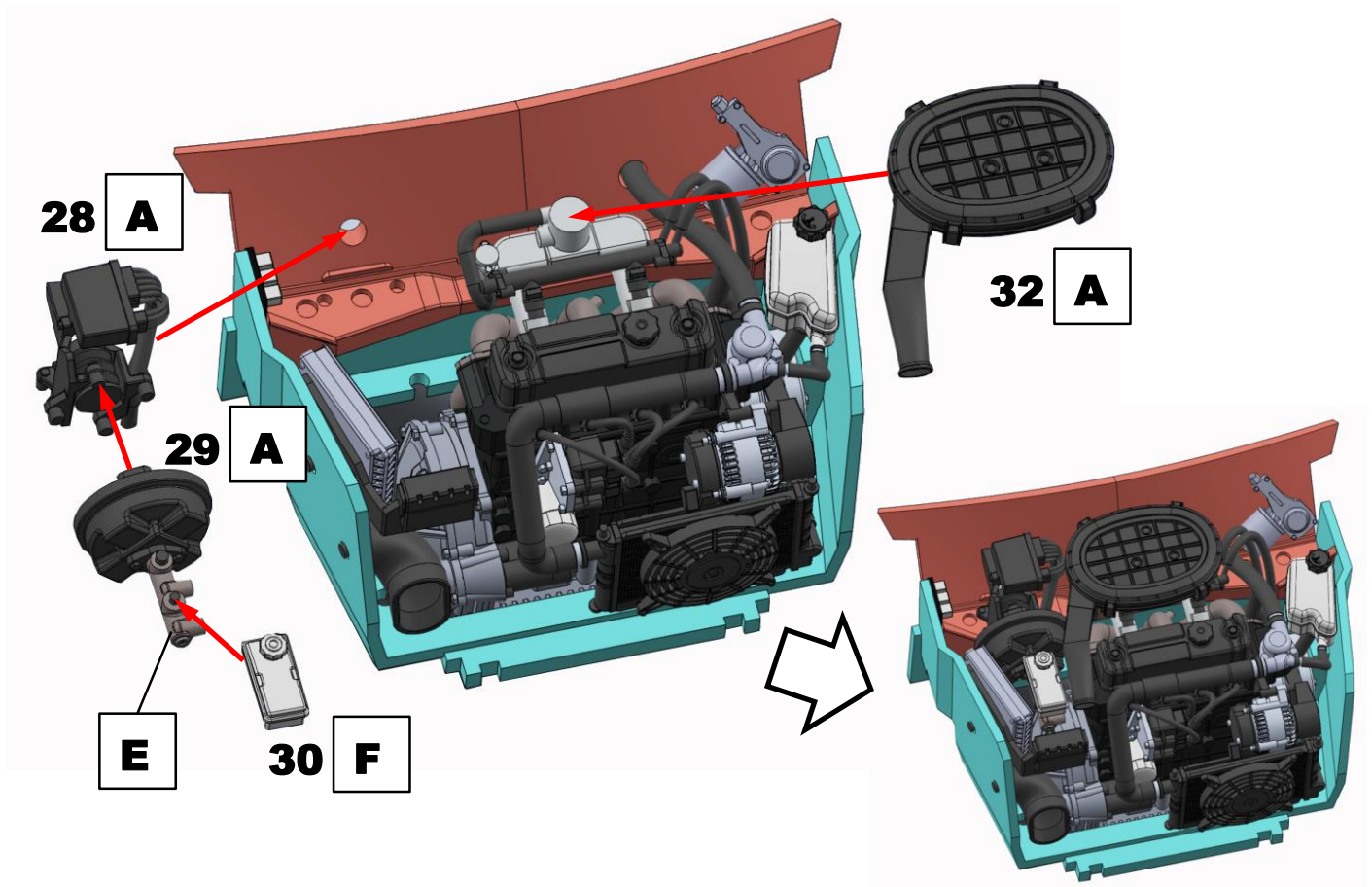

After this step, start assembling from step 1 of Hasegawa instruction. Part 33 install from inside of body, after cutting the bonnet

11. Bonnet

